

eurozappa

Forging ideas



2021

Catalogo generale

ZAPPETTE Blades Messern Couteaux Ножи	13
BULLONERIA SPECIALE PER ZAPPETTE Special bolts and nuts for blades Spezielle Schrauben für Messer Boulonnerie pour couteaux Специальные болты для ножей	49
COLTELLI PER SCAVAFOSSI Blades des trenchers Messer für Grabenfräse Couteaux pour fossoyeuses Ножи для траншеекопателей	53
DENTI PER ERPICE ROTANTE Tines for rotary harrows Kreiseleggenzinken Dents pour herse Зубья ротационной бороны	59
COLTELLI E LAME PER TRINCIA E DECESPUGLIATORI Knives and blades for choppers and flail-mowers Hammelschlägel und Schlägelmesser Couteaux et lames pour hacheuses et debroussailleuses Ножи и лезвия для мульчирователей и косилок	91
MAZZE PER TRINCIASARMENTI Hammer Hammerschlegel Marteaux pour broyeurs Молотковые ножи для мульчирования	117
RICAMBI PER ARATRI Spare parts for ploughs Ersatzteile für Pflüge Pieces detachees pour charrues Компоненты для плугов	135
MOLLE Cultivator tines Feingrubberzinken Dents pour vibroculteurs Культиваторные стойки	151

SOCS REVERSIBILI E VOMERI A LANCIA Reversible socs Umkehrbare SOCS und Breitschare Socs reversibles Культиваторные лапы	
COMPONENTI E SISTEMI PER COLTIVATORI Components and systems for cultivators Komponenten und Systeme für Grubber Composants et systèmes pour cultivateurs Системы и компоненты для культиваторов	243
DISCHI PER ERPICE, PER FRANGIZOLLE E PER SEMINATRICE Discs for harrows ploughs and seeders Disques pour herses, brise-mottes et semoirs Scheiben für Erdschollenbrecher, Sämaschine und Egge Диски для дисковых борон и сеялок	259
RASCHIETTI Scraper Schaber Grattoirs Скребки	273
LAME PER TOSATRICI DA PRATO Cutter blade Randstreifenmesser Couteaux de gyrobroyeur Ножи для газонокосилок	295

IL GRUPPO EUROZAPPA

EUROZAPPA'S GROUP

Eurozappa, **azienda italiana leader** nella produzione di componentistica per macchine agricole da oltre 40 anni, grazie all'esperienza maturata e alla forza dei suoi 3 poli industriali, oggi offre soluzioni per chi è impegnato in agricoltura e non solo, producendo forgiati e stampati secondo una filiera tutta interna all'azienda. La costante attenzione al mercato e alla clientela, il coordinamento e la sinergia di competenze e **conoscenze tecniche**, le **tecnologie all'avanguardia**, il personale specializzato, le aree dedicate a ricerca e sviluppo, il know-how acquisito e alimentato costantemente nel tempo, hanno consentito l'affiancamento alla tradizionale attività di forgiatura di utensili agricoli con lo stampaggio a caldo di componentistica e particolari per la meccanica in genere. Questo percorso ha reso Eurozappa capace di offrire una gamma di **prodotti di qualità** fra le più complete del mercato.

Eurozappa **esegue internamente tutto l'iter produttivo** dalla selezione dell'acciaio, alla realizzazione dell'utensile finale: la specializzazione di ogni polo nei settori della meccanica agricola e della meccanica in genere, garantisce una gamma di articoli unici e rispondenti agli standard qualitativi e tecnici più elevati. I **due poli produttivi di Bologna** realizzano tutta la gamma di articoli dedicata alla lavorazione del terreno, dalla semina alla raccolta. Il polo produttivo sito in Croazia è specializzato nello stampaggio a caldo di componenti sia per l'**agricoltura** che per altri settori quali **Automotive**, **Energetico** ed **Edile**. In tutti e tre i poli produttivi sono presenti linee di ultima generazione dedicate alla lavorazione meccanica e ai diversi e specifici trattamenti termici, il tutto controllato dalla sede centrale e certificato seguendo molteplici fasi di collaudo.

Eurozappa realizza più di **50 tipologie** di ricambi e componentistica per una produzione complessiva di **11 milioni di pezzi all'anno**: dischi, molle, mazze, vomeri, zappe e stampati industriali tra cui ange, ingranaggi, ruote industriali, cardani, alberi di trasmissione e mozzi. L'intera filiera produttiva, dal personale tecnico specializzato alle linee di ultima generazione, garantisce di proporre **soluzioni a catalogo** o **progetti customizzati** per essere al tuo fianco nell'ideare soluzioni innovative e funzionali.





Eurozappa, an Italian company that has been a **leader** in the manufacture of **components for agricultural machinery** for over 40 years, thanks to its wealth of experience and the strength of its **3 industrial poles**, today offers solutions for both those committed to agriculture and other sectors, producing forged and press-molded parts with the entire production system entirely inside the company structure. Constant attention to the marketplace and to customers, the coordination and synergy of the competencies and technical know-how, the **advanced technologies**, specialized personnel, the areas dedicated to research and development, the know-how acquired and constantly incremented over time, have permitted flanking the traditional activity of forging farming equipment with the hot-press stamping of components and other items for agricultural mechanical needs and other areas. This path has made Eurozappa capable of offering a range of **quality products** which is among the most complete on the market today.

Eurozappa carries out all manufacturing processes exclusively in-company to guarantee a unique range of items which possess the highest possible standards of quality and technical precision. The two production poles in Bologna produce a component parts for working the soil, from planting to harvesting. The production pole located in Croatia is specialized in hot press-forging of items both for **farming** and other sectors, such as **Automotive**, **Energy**, and **Construction**. All three production poles have **latest generation machine lines** dedicated to mechanical machining and related processes, and have specific heat-treatments, all controlled by the headquarter.

Eurozappa makes more than **50 types** of spare parts and component parts for the agricultural and mechanical industry for a final production total of **11 million** parts per year: discs, springs, hammers, plows, blades and hot press-forged industrial parts, such as flanges, gears, industrial wheels, universal joints, drive-shafts and hubs. Eurozappa proposes catalog solutions or study custom-tailored projects to be by your side in creating innovative and efficient solutions.



UNA STORIA LUNGA 50 ANNI

A 50-YEAR-LONG HISTORY

“Questo stesso spirito è la fiamma che ogni giorno guida, attraverso le scelte aziendali, a guardare verso il Domani.” - Eurozappa

Eurozappa nasce nel 1972 dallo spirito imprenditoriale di Giuseppe Brighenti, suo fondatore.

Partita come piccola azienda artigiana, Eurozappa ha assunto carattere di industria conosciuta a livello Mondiale grazie al valore di competenti figure manageriali e alle loro idee, in grado di precedere i bisogni del mercato. Avanguardia, Ascolto, Analisi, Attenzione, sono alcuni degli aspetti che hanno conferito valore aggiunto alle già presenti attitudini di Prodotto, Prezzo e Qualità.

Avanguardia significa predisposizione alla ricerca e alle novità, significa essere e saper essere punto di riferimento nel settore. Ascolto verso tutta la clientela, senza distinzione di dimensione. Analisi di ogni richiesta ed esigenza della clientela, ma anche Analisi del mercato locale e mondiale. Attenzione verso il territorio, l'ambiente di lavoro e la cura del personale.

Questi sono alcuni dei valori che hanno nutrito lo spirito del fondatore e conferito un'impronta distintiva all'azienda. Tale spirito, fatto proprio da tutto il personale che man mano ha affiancato e succeduto Giuseppe Brighenti, ha gettato le basi per lo sviluppo e la crescita di Eurozappa nel tempo, segnando il percorso da intraprendere fino ai giorni attuali.





“This same spirit is the flame that day by day, through the company choices, keeps us focused on tomorrow” - Eurozappa

Eurozappa was started in 1972 thanks to the spirit of enterprise of Giuseppe Brighenti, its founder. From its early beginnings as a small artisan company, Eurozappa became an industry with a worldwide reputation, thanks to the value of its competent management figures and their ideas, capable of foreseeing market needs. Forward thinking, Listening, Analysis, Attention, are only a few of the aspects which conferred added value to the characteristics already present of Product, Price and Quality.

Forward thinking means a predisposition to research and innovation. It means being and knowing how to be the point of reference in the sector. Listening to all customers, with no distinction for size. Analysis of every request and customer need, but also Analysis of the local and world markets. Attention towards the land, the work environment and taking care of personnel.

These are a few of the values that have nourished the spirit of our founder and conferred a distinctive imprinting to the company. This spirit, absorbed by all the persons who have little by little flanked and then come after Giuseppe Brighenti, have laid the basis for the growth and development of Eurozappa over the years, marking the path to take until our present days.



UN PROCESSO TUTTO INTERNO ALL'AZIENDA

AN ENTIRELY "IN COMPANY" PROCESS

PROGETTAZIONE CAD CAM

Personale tecnico specializzato studia la fattibilità produttiva e progetta, tramite software sempre più avanzati, le attrezzature necessarie per la realizzazione di nuovi prodotti.

CESOIATURA A FREDDO O TAGLIO LASER

Le strumentazioni all'avanguardia garantiscono il taglio del metallo ad altissima precisione e velocità di avanzamento. Ogni articolo viene tagliato, seguendo il progetto specifico, tramite cesoie automatiche o attraverso l'utilizzo di un impianto laser.

FORGIATURA CON FORNI A TEMPERATURA CONTROLLATA

L'utilizzo di forni alimentati a gas e ad induzione, permette lo stampaggio a caldo di nuovi particolari realizzati a disegno o di articoli presenti a catalogo.

TRATTAMENTI TERMICI DI TEMPRA CON RAFFREDDAMENTO

I sistemi di trattamento termico ad atmosfera controllata e ricottura isoterma continua, garantiscono le specifiche tecniche di durezza, resistenza e resilienza. I trattamenti termici vengono eseguiti sotto strettissimo controllo da parte del personale tecnico specializzato.

LAVORAZIONE MECCANICA CON MACCHINE C.N.C.

I macchinari effettuano qualsiasi tipo di lavorazione meccanica con le più ristrette tolleranze richieste. Gli impianti di tornitura e fresatura di ultima generazione, permettono di procedere su più piani di lavoro, dando la possibilità di realizzare figure complesse. Le lavorazioni meccaniche, di tornitura e di fresatura, possono essere effettuate direttamente sugli articoli stampati nel polo produttivo.

PALLINATURA E VERNICIATURA

La pallinatura consente di perfezionare il prodotto. Il risultato è un utensile puro, uniforme e resistente alle pressioni più forti. La verniciatura a polvere o a immersione ultima la lavorazione consegnando prodotti rifiniti in diverse colorazioni.

CONTROLLO E QUALITÀ

Per le verifiche metallurgiche e dimensionali si utilizzano sistemi di controllo 3D, microscopi e durometri, brinell, rockweell al fine di certificare il più elevato raggiungimento qualitativo, in linea con gli standard del Gruppo.

30 LINEE PRODUTTIVE
30 PRODUCTION LINES

+90% MATERIA PRIMA ITALIANA
+90% "MADE IN ITALY" SUPPLIERS



CAD CAM DESIGN

Specialized technical personnel studies manufacturing feasibility and designs, always using the most advanced software, the tools necessary for the making of new products.

COLD SHEARING AND LASER CUTTING

Modern instruments guarantee extremely high-precision metal cutting at high rates of advance. Each item is cut, following the specific design, using automatic shears or by means of a Laser cutting plant.

FORGING IN CONTROLLED TEMPERATURE OVENS

The use of gas-fed and induction ovens, permits hot press-forging of new, custom-design parts or items present in the catalog.

HEAT TREATMENT WITH COLD TEMPERING

The heat treatment systems using controller atmosphere and continuous exothermic annealing, guarantee the technical specs of hardness, strength and toughness. The heat treatments are carried out under the extremely careful control of specialized technicians.

C.N.C. PRECISION MACHINE TOOLS FOR MECHANICAL MACHINING

The machinery does any kind of mechanical machining with the strictest tolerances required. The lathe and mill plants are latest generation equipment, and permit handling the job on multiple planes, making it possible to handle even complex shapes. The mechanical machining, lathe turning and milling can be done directly on the press forged items in the production pole itself.

SANDBLASTING AND PAINTING

Sandblasting permits perfecting the product. The result is a tool that is pure, uniform and resistant to extreme stress. Powder or immersion painting completes the manufacturing process, providing finished products in different colors.

CHECKING AND QUALITY

For all the metallurgical and dimensional checks, 3D control systems are used, along with microscopes, Brinell and Rockwell hardometers, in order to ensure the highest level of quality certification, in line with the Group standards.

UNI EN ISO 9001:2008
QUALITY CERTIFICATION

2500 TON SEMPRE A MAGAZZINO
2500 TONS ALWAYS ON STOCK

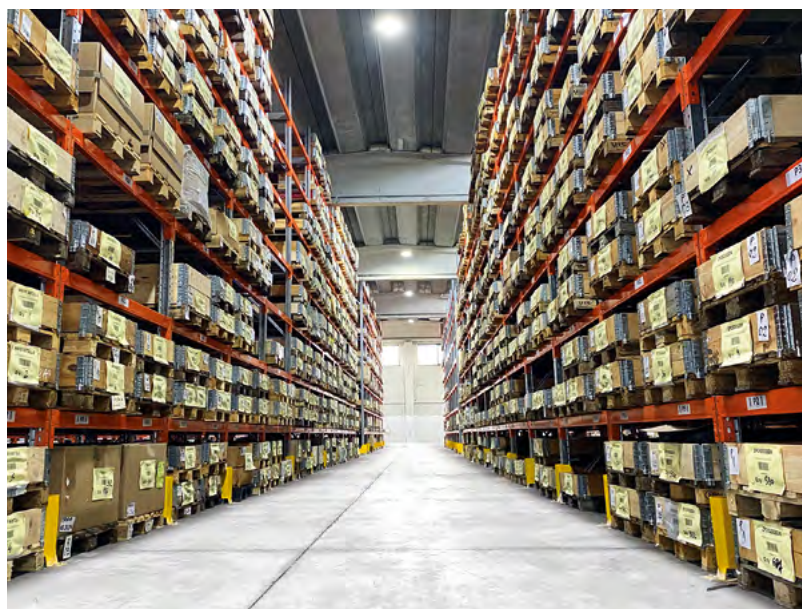

RIVESTIMENTI E TRATTAMENTI ANTI-USURA

ANTI-WEAR COATINGS AND TREATMENTS

Gli utensili Eurozappa possono essere forniti con diversi tipi di **rivestimento antiusura**. Ogni rivestimento viene valutato e proposto in funzione alle caratteristiche dell'usura e, in collaborazione con i nostri fornitori, siamo in grado di proporre soluzioni mirate alle singole applicazioni per un'**elevata resistenza all'abrasione**, aumentando la **vita utile** dell'utensile e rispettandone le specifiche tecniche e le geometrie.

Eurozappa tools can be supplied with different types of **anti-wear coating**. Each coating is evaluated and proposed according to wear characteristics and, in collaboration with our suppliers, we are able to propose solutions targeted to individual applications for **high abrasion resistance**, by increasing the tool life and respecting its technical specifications and geometries.

RIVESTIMENTO AI CARBURI DI TUNGSTENO

Si tratta di un rivestimento molto compatto con un'alta percentuale di **cromo** e **carburi di tungsteno**, effettuato ad alta temperatura ed in atmosfera controllata. Questo procedimento garantisce una perfetta coesione del rivestimento con il materiale di base e, quindi, la migliore **resistenza** e **tenacità** dell'utensile trattato. La durezza media del rivestimento è di 60/62 HRC. Gli spessori del rivestimento variano da 0,3 mm a 2 mm, a seconda della geometria del pezzo e delle sue applicazioni.

TUNGSTEN CARBIDE COATING

It is a very compact coating with a high percentage of **chrome** and **tungsten carbide**, made at high temperature and in a controlled atmosphere. This procedure guarantees perfect coating cohesion with the base material and, therefore, improved **resistance** and **toughness** of the treated tool. The average coating hardness is 60/62 HRC. Coating thicknesses range from 0,3 mm to 2 mm, depending on part geometry and its applications.



RIVESTIMENTO MEDIANTE SALDATURA

Il riporto è realizzato mediante saldatura a filo con composizioni chimiche e caratteristiche tecniche mirate all'applicazione, le quali conferiscono un'eccellente resistenza all'abrasione e una media resistenza agli impatti. La durezza media del rivestimento è di 60/62 HRC.

HARDFACING

Hardfacing is made through wire welding with chemical compositions and targeted technical characteristics, giving excellent resistance to abrasion and average resistance to impact. The average coating hardness is 60/62 HRC.



eurozappa

ZAPPETTE

Blades

Messern

Couteaux

Ножи





C/SX



C/DX



SQ/SX



SQ/DX

C - Zappa curva
C - Curved blade
C - Gekrümmtes Messer
C - Couteau Courbé
C - Нож полукруглый

SQ - Zappa squadro
SQ - Square blade
SQ - Rechteckmesser
SQ - Couteau en équerre
SQ - Нож с прямым углом

DX - Destra
DX - Right Hand
DX - Recht
DX - Droite
DX - Правый

SX - Sinistra
SX - Left Hand
SX - Links
SX - Gauche
SX - Левый

ZAPPETTE
Blades
Messern
Couteaux
Ножи

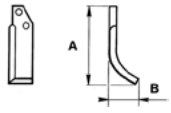
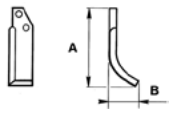
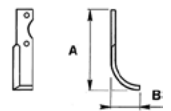

Marca della macchina Machine brand name Marke der Maschine Marque de la machine Марка машины	Codice Nr. Ref. Nr. Re. Nr. Ref. Nr. Код №	Quote Dimensions Abmessungen Dimensions Размеры mm	Curvatura Curvature Krümmung Courbure Изгиб	Piatto Plate Platte Plaque Профиль mm	Fori Holes Löcher Trous Отверстия Ø mm	Interasse Center distance Achsenabstand Entraxe Расстояние Ø - Ø	Peso Weight Gewicht Poids Вес gr
--	--	---	---	--	---	---	---

ADRIATICA								
Supermec	101003		A = 180 B = 85	C	40x6	10,5	46	350
Supermec-R	101007		A = 185 B = 75	C	50x6	10,5	46	470
Mিনny	101013		A = 172 B = 40	C	30x5	8,5	50	200

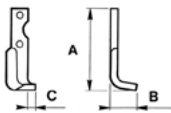
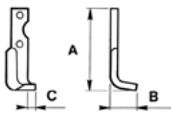
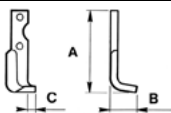
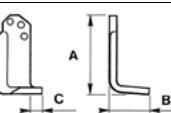
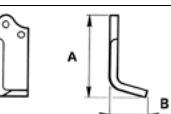
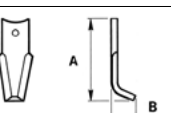
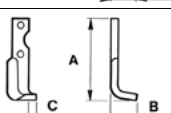
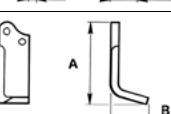
AGRIA								
1100 27130/29	103001		A = 160 B = 50 C = 20	SQ	30x4	8,5	70	160
2100 17548/49	103002		A = 175 B = 50 C = 20	SQ	30x4	8,5	70	180
6000/4000 21099/98	103003		A = 190 B = 50 C = 20	SQ	30x4	8,5	70	190
1900 3 fori 06038/39	103009		A = 200 B = 105 C = 30	SQ	70x6	10,5	36	820
6623/6624	103011A		A = 132 B = 58	SQ	50x5	10,5	38	280
1 foro 06622 = 1567	103013		A = 120 B = 35	SQ	40x4	6,5	—	170
6000 lunga 17222/23	103016		A = 205 B = 50 C = 20	SQ	30x4	8,5	70	200
2500 12868/69	103019		A = 155 B = 70 C = 20	SQ	50x5	10,5	38	320

Tutti i modelli sono di nostra produzione e non originali.
All models are of our manufacture and are not original.
Alle unsere Landwirtschaftliche erzeugnisse sind unsere produktion und sind nicht original.
Tous les modèles sont notre production et ne sont pas des produits d'origine.
Все модели нашего производства и не являются оригинальными.

N.B. Pesi e misure sopra descritti sono puramente indicativi.
N.B. The above weights and dimensions are given for reference only.
N.B. Die obengenannten Gewichte und Abmessungen sind richtungsweisend.
N.B. Les poids et les dimensions indiqués ci-dessus sont donnés à titre indicatif.
N.B. Указанные вес и размеры, являются ориентировочными.



© La riproduzione anche parziale del presente catalogo è vietata.



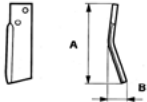

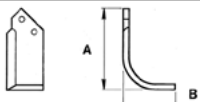
Marca della macchina Machine brand name Marke der Maschine Marque de la machine Марка машины	Codice Nr. Ref. Nr. Re. Nr. Ref. Nr. Код №	Quote Dimensions Abmessungen Dimensions Размеры mm	Curvatura Curvature Krümmung Courbure Изгиб	Piatto Plate Platte Plaque Профиль mm	Fori Holes Löcher Trous Отверстия Ø mm	Interasse Center distance Achsenabstand Entraxe Расстояние Ø - Ø	Peso Weight Gewicht Poids Вес gr
--	--	---	---	--	---	---	---

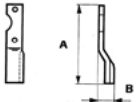
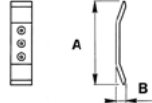
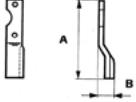
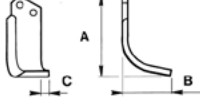
AGRIC								
Rotalabour	109001		A = 220 B = 65	—	60×12	14,5	46	1250

AGRITEC								
AT 40	114003		A = 160 B = 137	C	70×7	14,5	46	1070

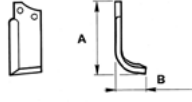
ALPEGO								
LD - LM - LP D0543/544	113001		A = 325 B = 45	—	60×10	15	130	1370
Vomere 3 fori D01310/11	113002		A = 430 B = 45	—	70×18	13	66	4175
LE 2 D01398/99	113004		A = 365 B = 43	—	70×10	16,5	150	1820
Esploratore KE D01590/91	113005		A = 200 B = 130 C = 18	C	80×8	14,5	57	1100
Rotopik D04864/65	113011		A = 370 B = 52	—	60×15	17	150	2600
Rotopik KP D04866/67	113012		A = 340 B = 42	—	50×12	14,5	130	1430

BADALINI								
Multifresa F. 777	118001		A = 138 B = 57	C	50×6	10,5	30	360
5145 76715145B	118016		A = 152 B = 45 C = 10	C	50×6	10,5	30	320

ZAPPETTE
Blades
Messern
Couteaux
Ножи



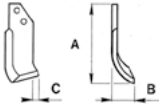

Marca della macchina Machine brand name Marke der Maschine Marque de la machine Марка машины	Codice Nr. Ref. Nr. Re. Nr. Ref. Nr. Код №		Quote Dimensions Abmessungen Dimensions Размеры mm	Curvatura Curvature Krümmung Courbure Изгиб	Piatto Plate Platte Plaque Профиль mm	Fori Holes Löcher Trous Отверстия Ø mm	Interasse Center distance Achsenabstand Entraxe Расстояние Ø - Ø	Peso Weight Gewicht Poids Вес gr
777/85	118018		A = 152 B = 58 C = 10	C	50x6	10,5	30	400

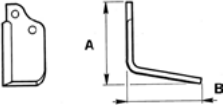
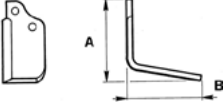
BAIANO

N.T. Lungo solo SX	119003		A = 150 B = 125	SQ	50x6	10,5	40	460
N.T. Corto solo SX	119004		A = 130 B = 120	SQ	50x6	10,5	40	420

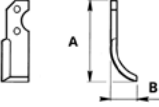
BARBIERI

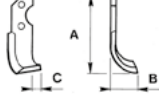
RLA 3 Airone 2109/10	121021		A = 195 B = 65	C	35x5	8,5	68	280
Gazzella RLG1 0606028/29	121032		A = 200 B = 69	C	40x5	10,5	68	320
MCG-16 1606004/5	121033		A = 200 B = 80 C = 8	C	40x6	10,5	76	380

BARONI

N.T.	122005		A = 220 B = 130	SQ	60x8	14,5	56	950
-------------	---------------	---	--------------------	----	------	------	----	-----

B.C.S.

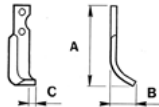
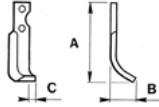
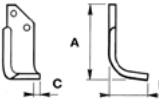
715 Grillino B4 43431/32	123001		A = 170 B = 55 C = 20	C	25x6	8,5	55	200
705 Standard 42306/7	123002		A = 190 B = 75 C = 20	C	30x6	10,5	66	280
705 Paternò 42304/5	123003		A = 160 B = 72 C = 15	C	50x6	10,5	41	370

Tutti i modelli sono di nostra produzione e non originali.
All models are of our manufacture and are not original.
Alle unsere Landwirtschaftliche erzeugnisse sind unsere produktion und sind nicht original.
Tous les modèles sont notre production et ne sont pas des produits d'origine.
Все модели нашего производства и не являются оригинальными.

N.B. Pesi e misure sopra descritti sono puramente indicativi.
N.B. The above weights and dimensions are given for reference only.
N.B. Die obengenannten Gewichte und Abmessungen sind richtungsweisend.
N.B. Les poids et les dimensions indiqués ci-dessus sont donnés à titre indicatif.
N.B. Указанные вес и размеры, являются ориентировочными.

© La riproduzione
anche parziale
del presente catalogo
è vietata.



Marca della macchina Machine brand name Marke der Maschine Marque de la machine Марка машины	Codice Nr. Ref. Nr. Re. Nr. Ref. Nr. Код №		Quote Dimensions Abmessungen Dimensions Размеры mm	Curvatura Curvature Krümmung Courbure Изгиб	Piatto Plate Platte Plaque Профиль mm	Fori Holes Löcher Trous Отверстия Ø mm	Interasse Center distance Achsenabstand Entraxe Расстояние Ø - Ø	Peso Weight Gewicht Poids Вес gr
725 48425/26	123004		A = 115 B = 56	C	40x6	10,5	27	210
735 Spagna 48433/34	123005		A = 130 B = 56	C	40x6	10,5	27	225
715 lungo tipo America 43433/34	123007		A = 185 B = 50 C = 20	C	25x6	8,5	55	240
Sicilia 745/66 49707/8	123010		A = 181 B = 72 C = 18	C	60x8	12,5	46	550
Coltello largo 48460/61	123012		A = 130 B = 56	C	50x7	10,5	27	310
Fresa 20 59275/76	123014		A = 193 B = 55 C = 25	C	30x6	8,5	55	270
Fresa 20 corta 592770/78	123015		A = 170 B = 55 C = 18	C	30x6	8,5	55	250

BENASSI

RT 12/4 6CM0300/1	125001		A = 165 B = 55	C	30x5	8,5	68	170
BL 50-55-60 6CM012/13	125019		A = 183 B = 60	C	35x5	8,5	68	260
RL 95 N.T. 6CM020/21	125023		A = 235 B = 70	C	50x6	10,5	80	540
Serie 300/304 6CM010/1100	125025		A = 205 B = 60	C	45x6	10,5	68	440
Serie 300/304 6CM008/900	125026		A = 208 B = 60 C = 10	SQ	45x6	10,5	68	460
BL 75 N.T./BL 85 6CM002/3	125027		A = 195 B = 60	C	40x5	8,5	68	300

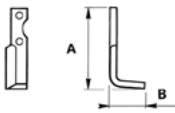
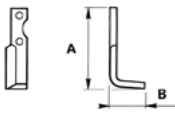
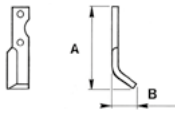
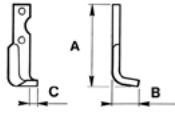
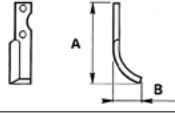
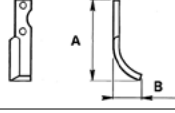
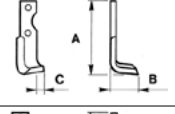
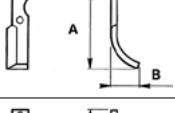
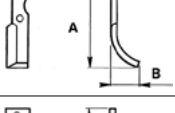
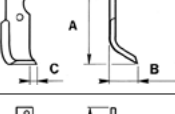
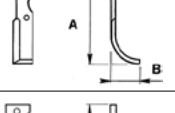
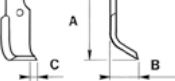
Marca della macchina Machine brand name Marke der Maschine Marque de la machine Марка машины	Codice Nr. Ref. Nr. Re. Nr. Ref. Nr. Код №		Quote Dimensions Abmessungen Dimensions Размеры mm	Curvatura Curvature Krümmung Courbure Изгиб	Piatto Plate Platte Plaque Профиль mm	Fori Holes Löcher Trous Отверстия Ø mm	Interasse Center distance Achsenabstand Entraxe Расстояние Ø - Ø	Peso Weight Gewicht Poids Вес gr
BL 75 N.T./BL 85 6CM004/005	125028		A = 192 B = 60	SQ	40x5	8,5	68	230
RT 401 6CM006/007	125030		A = 164 B = 50	SQ	30x4	8,5	68	190
RL 311 6CM014/15	125031		A = 175 B = 55 C = 15	C	30x5	8,5	68	200
RL 328 6CM0115/16	125039		A = 215 B = 60	C	40x5	10,5	68	340
RL 308 6CM0113/114	125040		A = 215 B = 70	C	40x6	10,5	68	430
RL 308 6CM105/106	125045		A = 215 B = 70 C = 15	SQ	40x6	10,5	68	430
RL 319 6CM125/126	125047		A = 196 B = 60	C	35x5	10,5	68	260
BL 35/BL 40 644011/12	125050		A = 197 B = 68	C	30x4	8,5	68	180
BL 90/348 - 105 - 110 644015/16	125054		A = 215 B = 74 C = 55	C	40x5	10,5	70	330
MC 230/240/250 64402700/2800	125058		A = 165 B = 55	C	30x5	8,5	50	200
BL 45 64402500/2600	125059		A = 210 B = 65 C = 26	C	35x4	8,5	68	250

BERTOLINI/EMAK

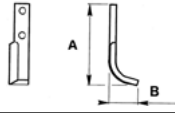
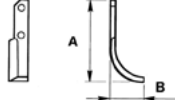
BM 10 101909/910	126001		A = 220 B = 70	C	30x8	10,5	58	450
300 671013/14	126004		A = 215 B = 78	C	30x6	8,5	81	340

Tutti i modelli sono di nostra produzione e non originali.
All models are of our manufacture and are not original.
Alle unsere Landwirtschaftliche erzeugnisse sind unsere produktion und sind nicht original.
Tous les modèles sont notre production et ne sont pas des produits d'origine.
Все модели нашего производства и не являются оригинальными.

N.B. Pesi e misure sopra descritti sono puramente indicativi.
N.B. The above weights and dimensions are given for reference only.
N.B. Die obengenannten Gewichte und Abmessungen sind richtungsweisend.
N.B. Les poids et les dimensions indiqués ci-dessus sont donnés à titre indicatif.
N.B. Указанные вес и размеры, являются ориентировочными.

© La riproduzione anche parziale del presente catalogo è vietata.



Marca della macchina Machine brand name Marke der Maschine Marque de la machine Марка машины	Codice Nr. Ref. Nr. Re. Nr. Ref. Nr. Код №		Quote Dimensions Abmessungen Dimensions Размеры mm	Curvatura Curvature Krümmung Courbure Изгиб	Piatto Plate Platte Plaque Профиль mm	Fori Holes Löcher Trous Отверстия Ø mm	Interasse Center distance Achsenabstand Entraxe Расстояние Ø - Ø	Peso Weight Gewicht Poids Вес gr
310/S 12522/23	126013		A = 245 B = 85	C	50x6	12,5	90	600
307 01353362/3262	126016		A = 184 B = 75	C	30x6	8,5	81	280
320-310 unificato 12031/32	126017		A = 255 B = 100	C	50x7	12,5	90	750
315 13014/15	126019		A = 145 B = 90	C	50x6	10,5	28	410
Fresa 65 cm 306 - 308 - 406 - 408 - 410 - 411 F015517/18	126023		A = 170 B = 72 C = 10	C	30x6	8,5	55	270
309 - 312 - 408 Motocoltivatore 15560/61	126024		A = 174 B = 65 C = 11	C	30x6	8,5	55	250
201/202E Motozappa 1233102/3	126025		A = 200 B = 60	C	30x4	8,5	65	200
401 - 402 - 403 - 405 F0017002/03	126026		A = 168 B = 65 C = 12	C	30x6	8,5	55	230
S.318 16812/3	126027		A = 145 B = 70	C	45x6	10,5	28	340
314 - 315 - 320	126032		A = 194 B = 65 C = 10	C	35x6	8,5	55	320

BONFIGLIOLI

Fresa spostabile serie da 28 pz. 14 SX Lunghe, 12 DX Lunghe, 2 DX Corte	128001		A = 230 B = 70 C = 40	C	35x8	10,5	106	520
--	--------	--	-----------------------------	---	------	------	-----	-----

BREVIGLIERI

MM Bietola 11076	134001		A = 190 B = 53 C = 15	SQ	30x6	8,5	70	290
-----------------------------------	--------	--	-----------------------------	----	------	-----	----	-----

ZAPPETTE
Blades
Messern
Couteaux
Ножи



Marca della macchina Machine brand name Marke der Maschine Marque de la machine Марка машины	Codice Nr. Ref. Nr. Re. Nr. Ref. Nr. Код №		Quote Dimensions Abmessungen Dimensions Размеры mm	Curvatura Curvature Krümmung Courbure Изгиб	Piatto Plate Platte Plaque Профиль mm	Fori Holes Löcher Trous Отверстия Ø mm	Interasse Center distance Achsenabstand Entraxe Расстояние Ø - Ø	Peso Weight Gewicht Poids Вес gr
B.3/4 30329	134003		A = 225 B = 96 C = 20	C	80x8	14,5	46	1080
B.1 10279	134006		A = 185 B = 115 C = 10	C	70x6	12,5	40	660
B.1 10303	134007		A = 185 B = 114 C = 20	SQ	70x6	12,5	40	720
B.12 0839	134008		A = 210 B = 130 C = 20	C	80x7	12,5	57	1000
Multipla MB/MBE S/10021	134010		A = 130 B = 55 C = 10	SQ	50x6	10,5	35	340
B.2 V/B 50 0840	134011		A = 178 B = 135 C = 25	SQ	80x7	12,5	57	1000
B.2 S/B 50 0839	134013		A = 205 B = 135 C = 25	C	80x7	12,5	57	960
B 20 105004	134020		A = 175 B = 110 C = 25	C	60x6	12,5	40	580
Dente per verticalfresa	134023		A = 210 B = 40	—	50x10	14,5	45	720
Verticalfresa	134047		A = 210 B = 40	—	60x10	16,5	45	920
MM 11077	134048		A = 101 B = 30 C = 6	C	50x5	8,5	40	200
MBE 1847	134058		A = 130 B = 55 C = 10	C	50x6	10,5	35	340

BRUMI

Diesel	136005A		A = 220 B = 70	C	40x6	10,5	70	410
---------------	---------	--	-------------------	---	------	------	----	-----

Tutti i modelli sono di nostra produzione e non originali.
All models are of our manufacture and are not original.
Alle unsere Landwirtschaftliche erzeugnisse sind unsere produktion und sind nicht original.
Tous les modèles sont notre production et ne sont pas des produits d'origine.
Все модели нашего производства и не являются оригинальными.

N.B. Pesi e misure sopra descritti sono puramente indicativi.
N.B. The above weights and dimensions are given for reference only.
N.B. Die obengenannten Gewichte und Abmessungen sind richtungsweisend.
N.B. Les poids et les dimensions indiqués ci-dessus sont donnés à titre indicatif.
N.B. Указанные вес и размеры, являются ориентировочными.

© La riproduzione
anche parziale
del presente catalogo
è vietata.



Marca della macchina Machine brand name Marke der Maschine Marque de la machine Марка машины	Codice Nr. Ref. Nr. Re. Nr. Ref. Nr. Код №		Quote Dimensions Abmessungen Dimensions Размеры mm	Curvatura Curvature Krümmung Courbure Изгиб	Piatto Plate Platte Plaque Профиль mm	Fori Holes Löcher Trous Отверстия Ø mm	Interasse Center distance Achsenabstand Entraxe Расстояние Ø - Ø	Peso Weight Gewicht Poids Вес gr
Diesel corto	136006A		A = 200 B = 60	C	40x6	10,5	70	380
Diesel	136007A		A = 222 B = 75	SQ	40x6	10,5	70	450
Diesel corto	136008A		A = 213 B = 60	SQ	40x6	10,5	70	410
Pulce	136012		A = 140 B = 47 C = 17	SQ	30x4	8,5	45	160
Klein	136013		A = 185 B = 60 C = 20	SQ	30x6	8,5	60	270
Maxi	136018		A = 200 B = 60	C	35x6	8,5	60	330
Maggiorata	136023		A = 238 B = 76	C	45x6	10,5	70	500
Maggiorata corta	136024		A = 210 B = 60	C	45x6	10,5	70	430
Maggiorata	136025		A = 235 B = 78	SQ	45x6	10,5	70	540
Maggiorata corta	136026		A = 210 B = 66	SQ	45x6	10,5	70	460
Maggiorata	136027		A = 238 B = 76	C	50x6	10,5	70	580
Maggiorata corta	136028		A = 210 B = 60	C	50x6	10,5	70	480
Muletto	136034		A = 178 B = 85	C	50x6	10,5	37	450
Klein super	136037		A = 225 B = 72	SQ	35x6	8,5	60	400

ZAPPETTE
Blades
Messern
Couteaux
Ножи



Marca della macchina Machine brand name Marke der Maschine Marque de la machine Марка машины	Codice Nr. Ref. Nr. Re. Nr. Ref. Nr. Код №		Quote Dimensions Abmessungen Dimensions Размеры mm	Curvatura Curvature Krümmung Courbure Изгиб	Piatto Plate Platte Plaque Профиль mm	Fori Holes Löcher Trous Отверстия Ø mm	Interasse Center distance Achsenabstand Entraxe Расстояние Ø - Ø	Peso Weight Gewicht Poids Вес gr
Asola	136038		A = 220 B = 70	SQ	40x6	10,5	68-80	420
C.A.B.								
Ringo M10	144009		A = 150 B = 60	SQ	50x6	10,5	30	360
CALDERONI								
FPS-FPF-FPP nuovo tipo serie da 28 pz. 14 SX Lunghe, 12 DX Lunghe, 2 DX Corte	139001		A = 220 B = 89 C = 58	C	40x8	10,5	106	640
CARRARO ANTONIO								
Super HP 13/18	147008		A = 178 B = 88	C	50x6	12,5	45	470
Mini Carrarino	147010		A = 180 B = 60 C = 12	C	30x6	8,5	55	270
CARRARO SPA								
Rotocar 3 fori Panther	148007		A = 182 B = 130	SQ	80x7	12,5	57-34	1150
Rotocar 3 fori Panther	148008		A = 182 B = 130	C	80x7	12,5	57-34	1000
Rotocar Mod. 7 Super serie 27	148010		A = 160 B = 130	C	60x6	12,5	44	580
CASORZO								
Pony 20140/20134	149014		A = 195 B = 80	C	30x6	8,5	72	300

Tutti i modelli sono di nostra produzione e non originali.
All models are of our manufacture and are not original.
Alle unsere Landwirtschaftliche erzeugnisse sind unsere produktion und sind nicht original.
Tous les modèles sont notre production et ne sont pas des produits d'origine.
Все модели нашего производства и не являются оригинальными.

N.B. Pesi e misure sopra descritti sono puramente indicativi.
N.B. The above weights and dimensions are given for reference only.
N.B. Die obengenannten Gewichte und Abmessungen sind richtungsweisend.
N.B. Les poids et les dimensions indiqués ci-dessus sont donnés à titre indicatif.
N.B. Указанные вес и размеры, являются ориентировочными.

© La riproduzione
anche parziale
del presente catalogo
è vietata.



Marca della macchina Machine brand name Marke der Maschine Marque de la machine Марка машины	Codice Nr. Ref. Nr. Re. Nr. Ref. Nr. Код №		Quote Dimensions Abmessungen Dimensions Размеры mm	Curvatura Curvature Krümmung Courbure Изгиб	Piatto Plate Platte Plaque Профиль mm	Fori Holes Löcher Trous Отверстия Ø mm	Interasse Center distance Achsenabstand Entraxe Расстояние Ø - Ø	Peso Weight Gewicht Poids Вес gr
	149015		A = 210 B = 65 C = 20	C	35x6	8,5	72	320
CU6-CU7 Meridione SU4 V.T.	149018		A = 210 B = 60	SQ	35x6	8,5	72	350
Pony 12 - 20155/156	149023		A = 190 B = 45	C	30x6	8,5	72	260

CELLI

Tipo E - HV - HF 422512/13	153003		A = 180 B = 135 C = 20	SQ	80x7	14,5	57	1030
Tipo E - HV - HF 422514/15	153004		A = 185 B = 135 C = 20	C	80x7	14,5	57	960
Pesante corto B 322514/15	153008		A = 242 B = 95	C	70x8	14,5	65	1080
Tipo A - HP20/35 522505/6	153010		A = 185 B = 135	C	70x6	12,5	50	710
Tipo A 522514/15	153011		A = 185 B = 135	SQ	70x6	12,5	50	780
Tipo B - BS 322518/19	153013		A = 195 B = 135 C = 20	C	80x6	14,5	57	850
Tipo B - BS 322516/17	153014		A = 180 B = 135 C = 20	SQ	80x6	14,5	57	880
Tipo G - K 722537/38	153015		A = 185 B = 135 C = 20	C	80x8	14,5	57	1100
Tipo G - K 722533/34	153016		A = 185 B = 135 C = 20	SQ	80x8	14,5	57	1160
Tipo AL - BA - HBA - FBA 522602/3	153017		A = 162 B = 120 C = 15	SQ	60x6	12,5	44	580

ZAPPETTE
Blades
Messern
Couteaux
Ножи



Marca della macchina Machine brand name Marke der Maschine Marque de la machine Марка машины	Codice Nr. Ref. Nr. Re. Nr. Ref. Nr. Код №		Quote Dimensions Abmessungen Dimensions Размеры mm	Curvatura Curvature Krümmung Courbure Изгиб	Piatto Plate Platte Plaque Профиль mm	Fori Holes Löcher Trous Отверстия Ø mm	Interasse Center distance Achsenabstand Entraxe Расстояние Ø - Ø	Peso Weight Gewicht Poids Вес gr
Tipo AL - BA - HBA - FBA 522600/1	153018		A = 170 B = 110 C = 22	C	60x6	12,5	44	520
TIPO G lungo 722535/36	153021		A = 245 B = 130 C = 20	SQ	80x8	14,5	57	1840
Dente Frangor Ø 16,5 FK 422630/1	153023		A = 202 B = 40	—	50x12	16,5	45	840
Tipo Kiwi HV - HF 522606/7	153024		A = 173 B = 85	C	60x6	12,5	44	500
Nuovo Tipo AG 531511/12	153025		A = 164 B = 110 C = 21	C	60x6	12,5	40	560
Tipo CE 331526/27	153027		A = 185 B = 136 C = 17	SQ	70x7	14,5	50	910
Tipo CE 331528/29	153028		A = 190 B = 130 C = 20	C	70x7	14,5	50	870
Pesante corta	153037		A = 228 B = 117 C = 20	SQ	80x8	14,5	64	1030
Pesante lunga	153038		A = 240 B = 123 C = 20	SQ	80x8	14,5	64	1430

COMEB

FL/P8/FP Bietola corta	158002		A = 120 B = 40	C	50x5	10,5	32	200
P9/FP Bietola	158003		A = 120 B = 55	C	50x5	10,5	32	240
R23/FPSR/A	158006		A = 160 B = 85	C	60x6	12,5	42	530
P7/FP Mais	158007		A = 135 B = 55	C	50x5	10,5	32	280

Tutti i modelli sono di nostra produzione e non originali.
All models are of our manufacture and are not original.
Alle unsere Landwirtschaftliche erzeugnisse sind unsere produktion und sind nicht original.
Tous les modèles sont notre production et ne sont pas des produits d'origine.
Все модели нашего производства и не являются оригинальными.

N.B. Pesi e misure sopra descritti sono puramente indicativi.
N.B. The above weights and dimensions are given for reference only.
N.B. Die obengenannten Gewichte und Abmessungen sind richtungsweisend.
N.B. Les poids et les dimensions indiqués ci-dessus sont donnés à titre indicatif.
N.B. Указанные вес и размеры, являются ориентировочными.

© La riproduzione
anche parziale
del presente catalogo
è vietata.

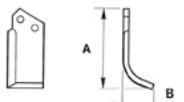
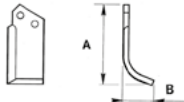
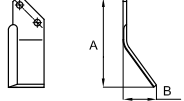

Marca della macchina Machine brand name Marke der Maschine Marque de la machine Марка машины	Codice Nr. Ref. Nr. Re. Nr. Ref. Nr. Код №		Quote Dimensions Abmessungen Dimensions Размеры mm	Curvatura Curvature Krümmung Courbure Изгиб	Piatto Plate Platte Plaque Профиль mm	Fori Holes Löcher Trous Отверстия Ø mm	Interasse Center distance Achsenabstand Entraxe Расстояние Ø - Ø	Peso Weight Gewicht Poids Вес gr
P10/FP	158014		A = 130 B = 40	C	50x5	10,5	32	250
R22/FPR-FPSR	158016		A = 145 B = 85	C	60x6	12,5	42	440
F47	158043		A = 200 B = 75	C	70x8	14,5	56	830

DEL MORINO

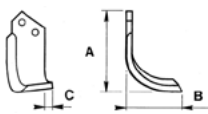
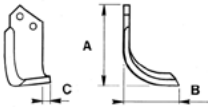
Tipo corto HOL 1540/215	165009		A = 160 B = 110 C = 15	C	60x6	12,5	34	540
Tipo nuovo lungo PRO250/251	165021		A = 180 B = 112 C = 15	C	60x8	12,5	34	800

DONDI

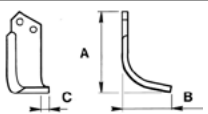
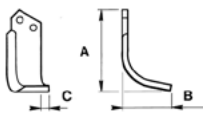
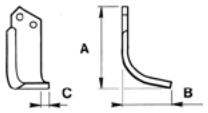
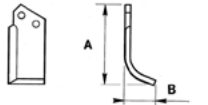
B	168007		A = 215 B = 110 C = 15	C	80x8	14,5	46	1140
0x7 per DCM/DCSM	168012		A = 190 B = 105 C = 20	C	70x7	12,5	40	800
0x6 per DCL/DCLS	168014		A = 190 B = 110 C = 20	C	70x6	12,5	40	700
BA per DFL 637001	168017		A = 150 B = 55	C	60x6	12,5	31	430

EBERHARDT

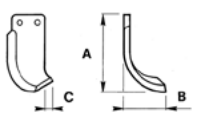
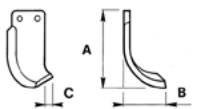
RKB471 1570/1571	174001		A = 185 B = 100 C = 10	C	80x6	14,5	45	770
RKB471 1560/1561	174004		A = 205 B = 100 C = 47	C	80x6	14,5	45	780

ZAPPETTE
Blades
Messern
Couteaux
Ножи

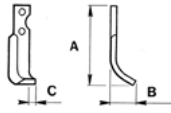
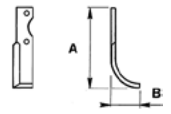
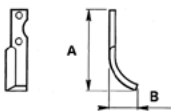

Marca della macchina Machine brand name Marke der Maschine Marque de la machine Марка машины	Codice Nr. Ref. Nr. Re. Nr. Ref. Nr. Код №		Quote Dimensions Abmessungen Dimensions Размеры mm	Curvatura Curvature Krümmung Courbure Изгиб	Piatto Plate Platte Plaque Профиль mm	Fori Holes Löcher Trous Отверстия Ø mm	Interasse Center distance Achsenabstand Entraxe Расстояние Ø - Ø	Peso Weight Gewicht Poids Вес gr
--	--	--	---	---	--	---	---	---

EUROSYSTEM								
MTZ Euro 50 00260015210/211	176003		A = 198 B = 78 C = 15	C	30x5	8,5	65	200
Euro 102 00220015206/207	176004		A = 215 B = 81	C	40x6	10,5	73	400
360015230/32	176013		A = 197 B = 60	C	30x4	8,5	65	160

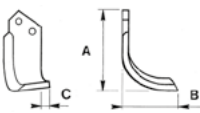
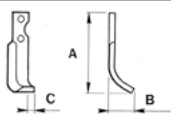
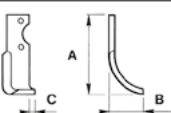
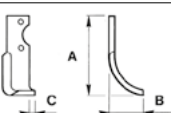
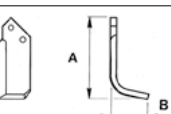
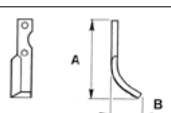
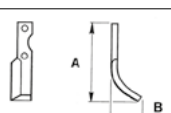
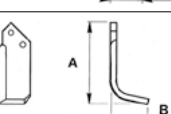
FERRARI								
Tipo 72 V.T. Super	186008		A = 150 B = 95 C = 20	C	50x6	10,5	25	420
Tipo 71/90	186010		A = 195 B = 80 C = 20	C	30x6	10,5	65	300
Tipo 74/75 lungo	186015		A = 260 B = 90 C = 20	C	60x7	12,5	90	925
Tipo 74/75 corto	186016		A = 265 B = 75 C = 20	C	60x7	12,5	90	880
Nuovo tipo 72 Fresa cm 90	186023		A = 145 B = 72	C	50x6	10,5	25	340
Tipo 92/91	186025		A = 195 B = 88	C	35x6	10,5	65	350
Tipo 300	186027		A = 183 B = 78	C	25x5	10,5	65	190
72 Fresa cm 80 MC 68	186030		A = 145 B = 100	C	50x6	10,5	25	460

Tutti i modelli sono di nostra produzione e non originali.
All models are of our manufacture and are not original.
Alle unsere Landwirtschaftliche erzeugnisse sind unsere produktion und sind nicht original.
Tous les modèles sont notre production et ne sont pas des produits d'origine.
Все модели нашего производства и не являются оригинальными.

N.B. Pesi e misure sopra descritti sono puramente indicativi.
N.B. The above weights and dimensions are given for reference only.
N.B. Die obengenannten Gewichte und Abmessungen sind richtungsweisend.
N.B. Les poids et les dimensions indiqués ci-dessus sont donnés à titre indicatif.
N.B. Указанные вес и размеры, являются ориентировочными.

© La riproduzione
anche parziale
del presente catalogo
è vietata.

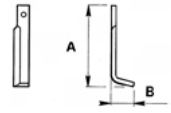
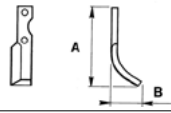
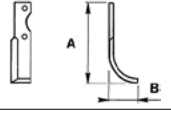
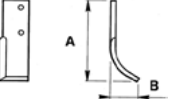

Marca della macchina Machine brand name Marke der Maschine Marque de la machine Марка машины	Codice Nr. Ref. Nr. Re. Nr. Ref. Nr. Код №		Quote Dimensions Abmessungen Dimensions Размеры mm	Curvatura Curvature Krümmung Courbure Изгиб	Piatto Plate Platte Plaque Профиль mm	Fori Holes Löcher Trous Отверстия Ø mm	Interasse Center distance Achsenabstand Entraxe Расстояние Ø - Ø	Peso Weight Gewicht Poids Вес gr
--	--	--	---	---	--	---	---	---

F.M.								
D7 N.T.	189001		A = 145 B = 45	SQ	30x5	8,5	—	180
R 4 L.300	189003		A = 235 B = 65	C	50x6	10,5	80	560
R 5 R100	189009		A = 235 B = 75	C	45x6	10,5	80	500
125/S	189014A		A = 205 B = 60	C	40x5	10,5	80	330

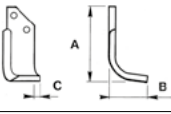
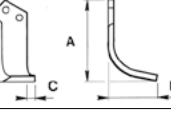
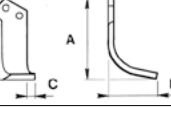
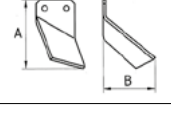
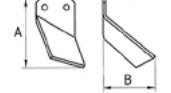

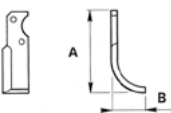
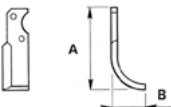
FORIGO								
Fresa F2 2095010	191010		A = 175 B = 110	C	70x7	12,5	46	730
Fresa F3 3156010	191012		A = 180 B = 125 C = 15	C	80x7	14,5	46	910
F1 1060010	191013		A = 175 B = 110 C = 25	C	60x6	12,5	42	580
Interrasassi G35 G3596100/110	191020		A = 160 B = 113	—	90x8	14,5	48	980
Interrasassi G45 G4595000/5100	191021		A = 177 B = 135	—	100x8	14,5	56	1240

FORT								
Tigrotto FT3 esterno 15075087/89	193009		A = 220 B = 77	C	45x6	10,5	65	480
Leone FL3 esterno NTZ Leone 15135043/50	193010		A = 237 B = 80	C	45x6	10,5	76	500

ZAPPETTE
Blades
Messern
Couteaux
Ножи

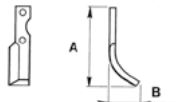

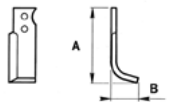
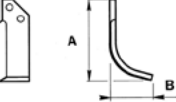
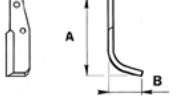
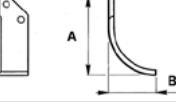
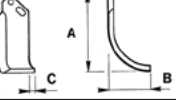
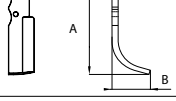
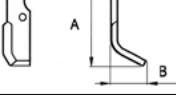
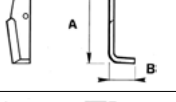
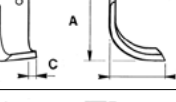
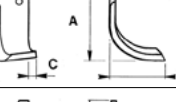
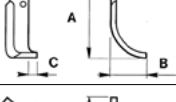
Marca della macchina Machine brand name Marke der Maschine Marque de la machine Марка машины	Codice Nr. Ref. Nr. Re. Nr. Ref. Nr. Код №		Quote Dimensions Abmessungen Dimensions Размеры mm	Curvatura Curvature Krümmung Courbure Изгиб	Piatto Plate Platte Plaque Профиль mm	Fori Holes Löcher Trous Отверстия Ø mm	Interasse Center distance Achsenabstand Entraxe Расстояние Ø - Ø	Peso Weight Gewicht Poids Вес gr
Minitigre Scarabeo NT FS3 15055077/78	193014		A = 195 B = 73	C	40x5	8,5	70	340

GOLDONI								
F22/23 0469/70	210008		A = 185 B = 75	C	35x6	8,5	33	350
Fresa 21 M 3884/85	210010		A = 158 B = 95	C	60x6	10,5	42	510
Fresa 28 primo tipo 0434/35	210016		A = 240 B = 110	C	60x6	10,5	99	700
Fresa 27/28/40	210026		A = 190 B = 110	C	70x6	12,5	54	710
Fresa 29/50 asola 9417/18	210027		A = 190 B = 105 C = 10	C	60x6	12,5	42	600
Fresa 22 N.T. con due lunette 9401/2	210029		A = 185 B = 80	C	45x5	10,5	33	340
Fresa 21 ultimo tipo fori inclinati 8833/34	210031		A = 195 B = 70	C	45x5	10,5	80	330
Fresa 21 N.T. lungo	210032		A = 195 B = 68	SQ	45x5	10,5	80	360
F/40S 9506/7	210033		A = 200 B = 115 C = 22	C	70x6	12,5	54	720
Fresa 22 M 4265/4312	210035		A = 165 B = 100 C = 15	C	60x6	10,5	42	540
Fresa 22 M N.T. 14486/87	210036		A = 200 B = 95 C = 20	C	45x5	10,5	42	400
Fresa 21 M N.T. 13545/46	210037		A = 152 B = 85	C	50x5	10,5	39	320

Tutti i modelli sono di nostra produzione e non originali.
All models are of our manufacture and are not original.
Alle unsere Landwirtschaftliche erzeugnisse sind unsere produktion und sind nicht original.
Tous les modèles sont notre production et ne sont pas des produits d'origine.
Все модели нашего производства и не являются оригинальными.

N.B. Pesi e misure sopra descritti sono puramente indicativi.
N.B. The above weights and dimensions are given for reference only.
N.B. Die obengenannten Gewichte und Abmessungen sind richtungsweisend.
N.B. Les poids et les dimensions indiqués ci-dessus sont donnés à titre indicatif.
N.B. Указанные вес и размеры, являются ориентировочными.

© La riproduzione
anche parziale
del presente catalogo
è vietata.



Marca della macchina Machine brand name Marke der Maschine Marque de la machine Марка машины	Codice Nr. Ref. Nr. Re. Nr. Ref. Nr. Код №		Quote Dimensions Abmessungen Dimensions Размеры mm	Curvatura Curvature Krümmung Courbure Изгиб	Piatto Plate Platte Plaque Профиль mm	Fori Holes Löcher Trous Отверстия Ø mm	Interasse Center distance Achsenabstand Entraxe Расстояние Ø - Ø	Peso Weight Gewicht Poids Вес gr
Fresa 60 N.T. 20136/37	210040		A = 205 B = 102 C = 10	C	60x6	12,5	53	590
Tipo 19 serie 1G 14191/193	210043		A = 175 B = 71 C = 10	C	40x6	10,5	70	340
Fresa 60 11098/11106	210050		A = 176 B = 110 C = 15	C	70x6	12,5	39	620
Tipo Pistoia	210051		A = 188 B = 80 C = 16	C	45x5	10,5	42	370

GRAMEGNA

ZL904/5	211002		A = 210 B = 110 C = 10	C	80x8	12,5	55	1060
----------------	--------	--	------------------------------	---	------	------	----	------

GRILLO (PINZA)

Castelguelfo 126-127 6 zappe 7087/88	212001		A = 140 B = 70 C = 18	C	35x6	8,5	21	230
GN10 Standard 131 4 zappe	212003		A = 190 B = 78 C = 22	C	30x6	10,5	66	280
Paternò 131 N.T. Grillino 7635/36	212005		A = 152 B = 72 C = 30	C	50x6	10,5	41	370
Grillino rinforzato 126-127 4 zappe 10203/4	212015		A = 195 B = 59 C = 28	C	30x6	8,5	55	290
Motozappa 11000 e Grillo V2 11293/94	212016		A = 202 B = 67 C = 20	C	35x6	10,5	66	340
Motozappa MTZ 12000 21385/86	212030		A = 210 B = 69	C	40x6	10,5	66	380
10569/70	212041		A = 175 B = 60 C = 35	C	30x6	8,5	55	260



ZAPPETTE
Blades
Messern
Couteaux
Ножи

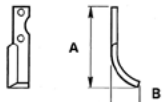

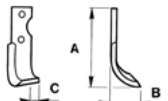
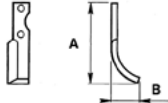
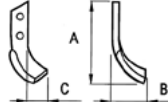
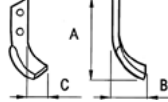
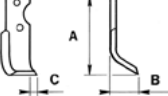
Marca della macchina Machine brand name Marke der Maschine Marque de la machine Марка машины	Codice Nr. Ref. Nr. Re. Nr. Ref. Nr. Код №		Quote Dimensions Abmessungen Dimensions Размеры mm	Curvatura Curvature Krümmung Courbure Изгиб	Piatto Plate Platte Plaque Профиль mm	Fori Holes Löcher Trous Отверстия Ø mm	Interasse Center distance Achsenabstand Entraxe Расстояние Ø - Ø	Peso Weight Gewicht Poids Вес gr
Princess 39011/12	212043		A = 197 B = 61	C	30x4	8,5	68	180

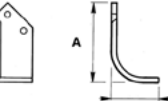
HONDA								
F400/78 Sciabola F560	224006		A = 200 B = 60 C = 30	C	35x6	8,5	70	340
F400/79 F410	224007		B = 205 C = 70	C	30x6	8,5	70	250
510/560 Sciabola	224014		A = 218 B = 75 C = 60	C	35x5	10,5	80	370
501	224015		A = 220 B = 75 C = 60	C	35x5	10,5	80	370
F300	224017		A = 211 B = 72 C = 60	C	40x4	8,5	70	280

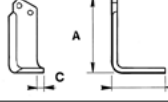
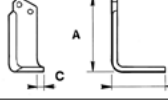
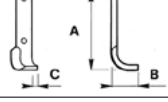
HORSH								
	140012		A = 202 B = 140	SQ	100x10	16,5	76	2050

HOWARD- ROTAVATOR								
Type HL-P 9900/1	225001		A = 165 B = 140 C = 30	SQ	80x6	11,5	57	870
Type U 63592/ 93-3900/01	225002		A = 180 B = 145 C = 20	SQ	80x7	13,5	57	1040
Type Rotocadet 9941/42	225003		A = 265 B = 96 C = 16	C	40x8	11,5	115	730
Type HL-P 9953/54	225004		A = 180 B = 140 C = 15	C	80x6	11,5	57	780

Tutti i modelli sono di nostra produzione e non originali.
All models are of our manufacture and are not original.
Alle unsere Landwirtschaftliche erzeugnisse sind unsere produktion und sind nicht original.
Tous les modèles sont notre production et ne sont pas des produits d'origine.
Все модели нашего производства и не являются оригинальными.

N.B. Pesi e misure sopra descritti sono puramente indicativi.
N.B. The above weights and dimensions are given for reference only.
N.B. Die obengenannten Gewichte und Abmessungen sind richtungsweisend.
N.B. Les poids et les dimensions indiqués ci-dessus sont donnés à titre indicatif.
N.B. Указанные вес и размеры, являются ориентировочными.

© La riproduzione
anche parziale
del presente catalogo
è vietata.



Marca della macchina Machine brand name Marke der Maschine Marque de la machine Марка машины	Codice Nr. Ref. Nr. Re. Nr. Ref. Nr. Код №		Quote Dimensions Abmessungen Dimensions Размеры mm	Curvatura Curvature Krümmung Courbure Изгиб	Piatto Plate Platte Plaque Профиль mm	Fori Holes Löcher Trous Отверстия Ø mm	Interasse Center distance Achsenabstand Entraxe Расстояние Ø - Ø	Peso Weight Gewicht Poids Вес gr
Type U 9948/49	225005		A = 205 B = 130 C = 20	C	80×7	13,5	57	1020
Type T 756784/85	225006		A = 205 B = 145	SQ	105×8	16,5	75	1640
Type HA-CA-Rotor 624400/01	225008		A = 175 B = 135 C = 20	SQ	80×7	11,5	57	1020
Type U Francese 63592/93-3900/01	225009		A = 180 B = 140	SQ	80×7	13,5	57	1040
Type HL-P Francese 9900/01	225010		A = 175 B = 135	SQ	75×6	11,5	57	820
Type HA 994881/981	225013		A = 180 B = 135 C = 10	C	80×7	13,5	57	910
Type KU 9862/3	225016		A = 175 B = 140	SQ	80×9	16,5	51	1350
Type KS 9950/1	225017		A = 210 B = 145	C	80×9	16,5	51	1400
Type Rotalabour 64750/255	225019		A = 230 B = 40	—	50×12	16,5	50	1000
Type long-shank 9910/11	225024		A = 210 B = 137	SQ	90×8	16,5	51	1530
9862/9863	225025		A = 175 B = 140	SQ	90×8	16,5	51	1300
Type 63604/605	225026		A = 175 B = 142	SQ	90×8	13,5	57	1300
Type rotaslasher 72900	225027		A = 315 B = 18	—	75×12	32	—	2000
Type rotaslasher 78663	225028		A = 390 B = 51	—	75×12	32	—	2550

ZAPPETTE
Blades
Messern
Couteaux
Ножи



Marca della macchina Machine brand name Marke der Maschine Marque de la machine Марка машины	Codice Nr. Ref. Nr. Re. Nr. Ref. Nr. Код №		Quote Dimensions Abmessungen Dimensions Размеры mm	Curvatura Curvature Krümmung Courbure Изгиб	Piatto Plate Platte Plaque Профиль mm	Fori Holes Löcher Trous Отверстия Ø mm	Interasse Center distance Achsenabstand Entraxe Расстояние Ø - Ø	Peso Weight Gewicht Poids Вес gr
Type rotaslasher J 14110	225029		A = 530	—	75×10	32	—	3000
Rotalabour Super 653256/57	225030		A = 230 B = 40	—	60×12	16,5	50	1200
Rotaslasher 73955	225037		A = 470	—	75×12	32,5	—	3230
3900/3901	225040		A = 180 B = 140	SQ	90×6	13,5	57	1000
Rotalabour 1 foro 3828/29	225043		A = 250 B = 38	—	60×12	16,5	—	1250
Type T	225046		A = 210 B = 140	C	105×8	16,5	75	1650

KRONE

RE-RES-RE/S45+65KS 0035268DX 0035435SX	236001		A = 185 B = 135	SQ	65×7	14,5	35	800
RL 1.00-1.25-1.75 0034020/0034109	236007		A = 265 B = 100 C = 10	C	40×8	12,5	120	720
REV-RE/S 85+120 0036273DX 0036395SX	236008		A = 190 B = 140	SQ	80×7	14,5	57	1050

KUBOTA

Tiller	222001		A = 240 B = 50	C	40×10	11	—	810
Tiller	222002		A = 250 B = 50	C	40×8	10	—	670
Tiller	222003		A = 206 B = 42	C	40×8	10,5	—	500

Tutti i modelli sono di nostra produzione e non originali.
All models are of our manufacture and are not original.
Alle unsere Landwirtschaftliche erzeugnisse sind unsere produktion und sind nicht original.
Tous les modèles sont notre production et ne sont pas des produits d'origine.
Все модели нашего производства и не являются оригинальными.

N.B. Pesi e misure sopra descritti sono puramente indicativi.
N.B. The above weights and dimensions are given for reference only.
N.B. Die obengenannten Gewichte und Abmessungen sind richtungsweisend.
N.B. Les poids et les dimensions indiqués ci-dessus sont donnés à titre indicatif.
N.B. Указанные вес и размеры, являются ориентировочными.

© La riproduzione anche parziale del presente catalogo è vietata.

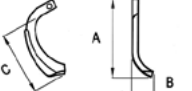

Marca della macchina Machine brand name Marke der Maschine Marque de la machine Марка машины	Codice Nr. Ref. Nr. Re. Nr. Ref. Nr. Код №		Quote Dimensions Abmessungen Dimensions Размеры mm	Curvatura Curvature Krümmung Courbure Изгиб	Piatto Plate Platte Plaque Профиль mm	Fori Holes Löcher Trous Отверстия Ø mm	Interasse Center distance Achsenabstand Entraxe Расстояние Ø - Ø	Peso Weight Gewicht Poids Вес gr
Tiller	222006		A = 206 B = 48	C	40x10	10,5	—	610

KUHN								
Type EL 45 52106305/6405	237001		A = 165 B = 135	SQ	75x6	11,5	57	750
52359000/591	237004		A = 193 B = 135	SQ	105x8	16,5	76	1770
Type cultilabour 51916504/66	237006		A = 210 B = 25	—	50x12	16,5	50	930
Type EL 100/N EL 80 51921501/16	237008		A = 165 B = 135	SQ	80x7	14,5	57	1000
Cultirotor EL 31 52324810/91	237023		A = 165 B = 135	SQ	90x8	16,5	57	1270
EL 32 51503200/33	237028		A = 241 B = 115 C = 11	C	60x6	12,5	86	710
519370/1 K16019300/19400	237034		A = 180 B = 130	SQ	70x6	12,5	41,5	760
K163103/104	237035		A = 180	—	50x12	16,5	—	980

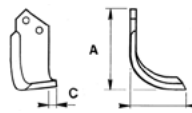
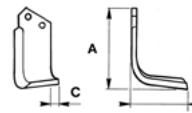
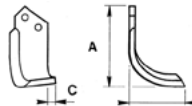
KVERNELAND								
P e M 0100077/78	252001		A = 195 B = 120 C = 15	C	70x8	14,5	46	1020
P e M 0100079/80	252002		A = 200 B = 115 C = 15	SQ	70x8	14,5	46	1120
B-908/909 0500077/78	252003		A = 195 B = 120 C = 15	C	80x8	14,5	46	1160

ZAPPETTE
Blades
Messern
Couteaux
Ножи



Marca della macchina Machine brand name Marke der Maschine Marque de la machine Марка машины	Codice Nr. Ref. Nr. Re. Nr. Ref. Nr. Код №		Quote Dimensions Abmessungen Dimensions Размеры mm	Curvatura Curvature Krümmung Courbure Изгиб	Piatto Plate Platte Plaque Профиль mm	Fori Holes Löcher Trous Отверстия Ø mm	Interasse Center distance Achsenabstand Entraxe Расстояние Ø - Ø	Peso Weight Gewicht Poids Вес gr
B 0500079/80	252004		A = 188 B = 125 C = 18	SQ	80x8	14,5	46	1220
PL 1300077/78	252007		A = 180 B = 105 C = 20	C	60x7	14,5	46	760
PL 1300079/80	252008		A = 180 B = 105 C = 15	SQ	60x7	14,5	46	810
L 1400079/80	252009		A = 248 B = 93	SQ	40x8	12,5	105	720
L 1400077/78	252010		A = 247 B = 93	C	40x8	12,5	105	650
Modulo corto Lama K 1101077	252023		A = 186 B = 25	—	80x8	14,5	45	810
Modulo medio Lama K 1101078	252024		A = 185 B = 65	—	80x8	14,5	45	890
Modulo lungo Lama K 1101079	252025		A = 185 B = 111	—	80x8	14,5	45	980
Tipo XP 1600079/80	252026		A = 190 B = 110 C = 15	SQ	70x8	14,5	46	940
PL nuovo tipo PL1302079/80	252031		A = 185 B = 105 C = 15	SQ	60x7	14,5	40	740
PL nuovo tipo PL1302077/78	252032		A = 185 B = 105 C = 18	C	60x7	14,5	40	700
PL lungo 1302177/78	252065		A = 178 B = 113 C = 30	C	60x7	14,5	40	710

MAB

Cicala 3149	250001		A = 165 B = 50 C = 20	SQ	30x4	8,5	55	170
------------------------------	--------	--	-----------------------------	----	------	-----	----	-----

Tutti i modelli sono di nostra produzione e non originali.
All models are of our manufacture and are not original.
Alle unsere Landwirtschaftliche erzeugnisse sind unsere produktion und sind nicht original.
Tous les modèles sont notre production et ne sont pas des produits d'origine.
Все модели нашего производства и не являются оригинальными.

N.B. Pesi e misure sopra descritti sono puramente indicativi.
N.B. The above weights and dimensions are given for reference only.
N.B. Die obengenannten Gewichte und Abmessungen sind richtungsweisend.
N.B. Les poids et les dimensions indiqués ci-dessus sont donnés à titre indicatif.
N.B. Указанные вес и размеры, являются ориентировочными.

© La riproduzione
anche parziale
del presente catalogo
è vietata.



Marca della macchina Machine brand name Marke der Maschine Marque de la machine Марка машины	Codice Nr. Ref. Nr. Re. Nr. Ref. Nr. Код №		Quote Dimensions Abmessungen Dimensions Размеры mm	Curvatura Curvature Krümmung Courbure Изгиб	Piatto Plate Platte Plaque Профиль mm	Fori Holes Löcher Trous Отверстия Ø mm	Interasse Center distance Achsenabstand Entraxe Расстояние Ø - Ø	Peso Weight Gewicht Poids Вес gr
Formica 3T esterna NF1 6121	250005		A = 222 B = 68	C	40x5	10,5	85	340
Talpa TL85 5161	250006		A = 160 B = 95	C	45x6	10,5	30	410
Curva lunga Formica 4189	250007		A = 232 B = 67	C	40x6	10,5	85	460
Lunga Formica 4152	250008		A = 246 B = 68	SQ	40x6	10,5	85	490

MASCHIO

B/BI/C/SC 01110428/29	255012		A = 215 B = 140 C = 25	SQ	80x8	14,5	56	1320
B/BI/C/SC 01110426/27	255013		A = 225 B = 142 C = 18	C	80x8	14,5	56	1250
NC-PS-Z V.T. 02108430/31	255014		A = 180 B = 135 C = 18	SQ	80x6	14,5	56	880
NC-PS-Z V.T. 02108432/33	255015		A = 192 B = 135 C = 15	C	80x6	14,5	56	845
R 2-3 M00566103/153	255016		A = 195 B = 83 C = 10	C	60x6	12,5	65	580
NCE AEM 19100421/22	255017		A = 195 B = 115 C = 18	SQ	70x6	12,5	44	740
NCE	255018		A = 208 B = 115 C = 18	C	70x6	12,5	44	740
A/E/KS 19100415/16	255019		A = 190 B = 117 C = 20	SQ	60x6	12,5	44	660
A/E/KS 19100417/18	255020		A = 194 B = 115 C = 12	C	60x6	12,5	44	610



Marca della macchina Machine brand name Marke der Maschine Marque de la machine Марка машины	Codice Nr. Ref. Nr. Re. Nr. Ref. Nr. Код №		Quote Dimensions Abmessungen Dimensions Размеры mm	Curvatura Curvature Krümmung Courbure Изгиб	Piatto Plate Platte Plaque Профиль mm	Fori Holes Löcher Trous Отверстия Ø mm	Interasse Center distance Achsenabstand Entraxe Расстояние Ø - Ø	Peso Weight Gewicht Poids Вес gr
Roter-fresa HB-HM/HL 10100262/63	255021		A = 335 B = 40 C = 16	—	60x10	13	44	1250
Roter-fresa HB-HM/HL 10100225/26	255022		A = 335 B = 40 C = 16	—	60x12	13	44	1510
G M20100412/13	255025		A = 265 B = 148 C = 30	C	90x10	16,5	68	1950
G M20100414/15	255026		A = 246 B = 140 C = 16	SQ	90x10	16,5	68	2040
K 21100412/13	255027		A = 164 B = 58	C	60x6	10,5	56	550
Protezione dente HB-HM-HL 10100247	255034		A = 100 B = 20	—	75x6	12,5	44	320
Dente cobra super 26100417/18	255035		A = 180 B = 42	—	80x8	14,5	44	870
Type U V.T. 29100405/6	255036		A = 210 B = 130 C = 18	C	80x6	14,5	48	960
Type U V.T.	255037		A = 200 B = 130 C = 14	SQ	80x6	14,5	48	990
Tipo W M48000404/5	255047		A = 180 B = 115 C = 22	C	60x6	12,5	44	600
A-E-H 19100423/24	255053		A = 193 B = 110 C = 20	C	70x6	12,5	44	700
NC-PS-Z Nuovo tipo 02108430/31	255065		A = 180 B = 135 C = 18	SQ	80x7	14,5	56	1020
NC-PS-Z Nuovo tipo 02108432/33	255066		A = 192 B = 135 C = 15	C	80x7	14,5	56	980
U Nuovo tipo - US/UZ 29100405/6	255067		A = 210 B = 130 C = 18	C	80x7	14,5	48	1100

Tutti i modelli sono di nostra produzione e non originali.
All models are of our manufacture and are not original.
Alle unsere Landwirtschaftliche erzeugnisse sind unsere produktion und sind nicht original.
Tous les modèles sont notre production et ne sont pas des produits d'origine.
Все модели нашего производства и не являются оригинальными.

N.B. Pesi e misure sopra descritti sono puramente indicativi.
N.B. The above weights and dimensions are given for reference only.
N.B. Die obengenannten Gewichte und Abmessungen sind richtungsweisend.
N.B. Les poids et les dimensions indiqués ci-dessus sont donnés à titre indicatif.
N.B. Указанные вес и размеры, являются ориентировочными.

© La riproduzione
anche parziale
del presente catalogo
è vietata.



Marca della macchina Machine brand name Marke der Maschine Marque de la machine Марка машины	Codice Nr. Ref. Nr. Re. Nr. Ref. Nr. Код №		Quote Dimensions Abmessungen Dimensions Размеры mm	Curvatura Curvature Krümmung Courbure Изгиб	Piatto Plate Platte Plaque Профиль mm	Fori Holes Löcher Trous Отверстия Ø mm	Interasse Center distance Achsenabstand Entraxe Расстояние Ø - Ø	Peso Weight Gewicht Poids Вес gr
U Nuovo tipo - US/UZ 29100407/8	255068		A = 200 B = 130 C = 14	SQ	80x7	14,5	48	1150
AE	255071		A = 187 B = 110 C = 8	SQ	70x6	12,5	44	740
Cultitiller M74100411/12	255074		A = 265 B = 28	—	50x15	17,5	—	1180
Pantera M09400414/415	255104		A = 210 B = 150 C = 22	C	90x10	16,5	56	1900



MEAAT

FP 1274/2149	259002		A = 135 B = 60 C = 10	SQ	50x6	10,5	35	340
CR 22 - FA 1805/2146	259009		A = 145 B = 80	C	60x6	12,5	42	440

MERITANO

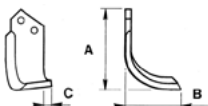
Medio	262002		A = 175 B = 105 C = 20	SQ	80x8	14,5	50	1020
Grande Tipo pesante	262003		A = 200 B = 110 C = 20	SQ	80x8	14,5	50	1230
TL	262008		A = 184 B = 105 C = 22	C	80x7	14,5	50	910
M Tipo pesante	262009		A = 190 B = 118 C = 18	C	80x8	14,5	50	1165
TLS	262025		A = 187 B = 115 C = 30	SQ	80x7	14,5	50	1040
TLO	262026		A = 190 B = 125 C = 20	C	80x8	14,5	50	1130

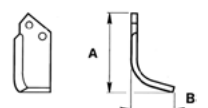
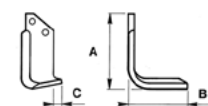
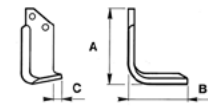
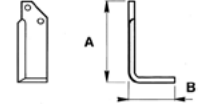
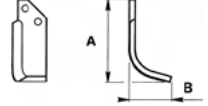
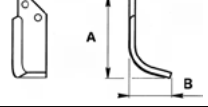
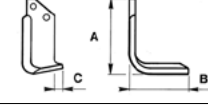
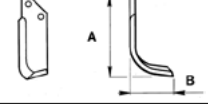
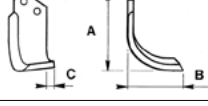
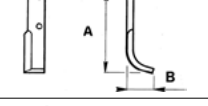
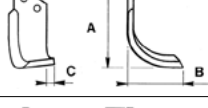
Marca della macchina Machine brand name Marke der Maschine Marque de la machine Марка машины	Codice Nr. Ref. Nr. Re. Nr. Ref. Nr. Код №		Quote Dimensions Abmessungen Dimensions Размеры mm	Curvatura Curvature Krümmung Courbure Изгиб	Piatto Plate Platte Plaque Профиль mm	Fori Holes Löcher Trous Отверстия Ø mm	Interasse Center distance Achsenabstand Entraxe Расстояние Ø - Ø	Peso Weight Gewicht Poids Вес gr
TL N.T.	262027		A = 185 B = 113 C = 22	C	80x7	14,5	50	1020

MURATORI								
MPR-MS2 180/215 - 220	268003		A = 200 B = 110	C	80x8	14,5	46	1100
MS3P-140-160 MS2-100-120 1200070/80	268004		A = 158 B = 108 C = 7	SQ	70x7	12,5	46	800
MS3P-180 MS2-140-160-215 1200020/21	268004A		A = 158 B = 108 C = 7	SQ	70x7	14,5	46	800
MS2P 12000301/401	268005		A = 188 B = 110	SQ	60x6	12,5	46	650
MS3P-180 1200050/60	268006		A = 185 B = 110	C	70x7	12,5	46	800
MS2 140-160 MS3P 180 1200013/14	268006A		A = 185 B = 110	C	70x7	14,5	46	800
Tipo lungo - MS3P 85/160 1200022/23	268007		A = 168 B = 149 C = 8	SQ	70x7	12,5	46	900
Tipo MS3P-MAS Fresa spostabile 12000101/201	268008		A = 185 B = 110	C	60x6	12,5	46	600
120015/16	268010		A = 195 B = 115 C = 10	C	80x8	14,5	46	1070
MA 85/145 120030/31	268012		A = 275 B = 120	C	60x6	12,5	123	870
MS3P 110-160 6 zappe lunga 12002801/2901	268013		A = 170 B = 145 C = 15	C	70x7	12,5	46	850
MZ2S - M85 - 125 spostabile 12014200/14300	268020		A = 135 B = 110 C = 10	C	50x6	10,5	27	380

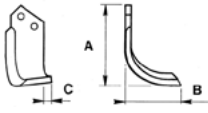
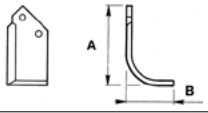
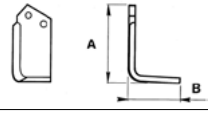
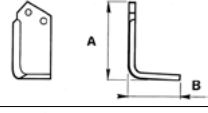
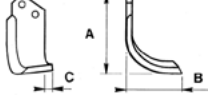

Marca della macchina Machine brand name Marke der Maschine Marque de la machine Марка машины	Codice Nr. Ref. Nr. Re. Nr. Ref. Nr. Код №	Quote Dimensions Abmessungen Dimensions Размеры mm	Curvatura Curvature Krümmung Courbure Изгиб	Piatto Plate Platte Plaque Профиль mm	Fori Holes Löcher Trous Отверстия Ø mm	Interasse Center distance Achsenabstand Entraxe Расстояние Ø - Ø	Peso Weight Gewicht Poids Вес gr
--	--	---	---	--	---	---	---

NARDI								
8C 5013	275019		A = 200 B = 135 C = 25	C	80x7	14,5	55	1100
5C 5012 N.T. ZL - ZLI interfila	275022		A = 175 B = 115	C	75x7	12,5	55	840
8C 5003 ZR - Z - ZC	275028		A = 203 B = 136	SQ	80x8	14,5	55	1180
5½ C 5002 ZM	275031		A = 185 B = 117	SQ	80x7	12,5	55	1050
6C 5009	275034		A = 180 B = 100 C = 26	C	75x7	12,5	45	810

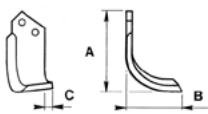
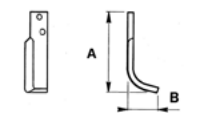
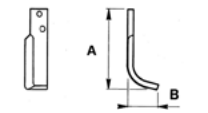
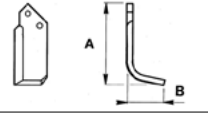
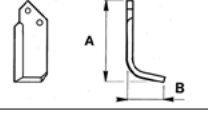
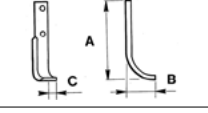
NIBBI BRUNO EMAK								
G 119	276008		A = 205 B = 85 C = 25	C	60x6	12,5	42	570
Artiglio E N.T. 519	276010		A = 180 B = 68	C	35x6	8,5	37	330
G 719 N.T.	276012		A = 150 B = 56	C	30x6	8,5	37	250
G 519 ultimo tipo 430255/56	276014		A = 150 B = 67	C	50x5	8,5	42	340
G 519 nuovo tipo 314 - 600 - 700 430323/24	276014A		A = 150 B = 67	C	50x5	10,5	42	340
Motocoltivatore 401 - 402 - 403 top Max 305 K3501780/90	276017		A = 170 B = 52 C = 20	C	25x5	8,5	58	180

ZAPPETTE
Blades
Messern
Couteaux
Ножи

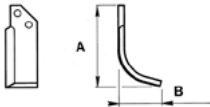

Marca della macchina Machine brand name Marke der Maschine Marque de la machine Марка машины	Codice Nr. Ref. Nr. Re. Nr. Ref. Nr. Код №	Quote Dimensions Abmessungen Dimensions Размеры mm	Curvatura Curvature Krümmung Courbure Изгиб	Piatto Plate Platte Plaque Профиль mm	Fori Holes Löcher Trous Отверстия Ø mm	Interasse Center distance Achsenabstand Entraxe Расстояние Ø - Ø	Peso Weight Gewicht Poids Вес gr
--	--	---	---	--	---	---	---

O.M.M.A.S.								
FS-M5 interfilare serie da 16 pz. 10 SX / 6 DX	287001		A = 170 B = 100	C	40x8	12,5	41	490

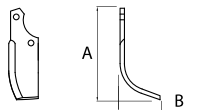
ORTOLAN								
Ortolan	292002		A = 201 B = 88	C	60x6	12,5	65	530

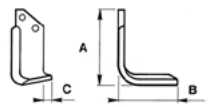
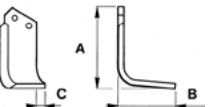
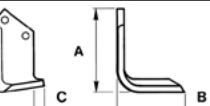
PALLADINO								
Leggero 560104	298001		A = 158 B = 110 C = 10	SQ	70x6	12,5	42	710
Medio	298002		A = 160 B = 118 C = 35	SQ	80x7	14,5	57	900
Pesante 560107	298003		A = 180 B = 130 C = 33	SQ	80x8	14,5	57	1160

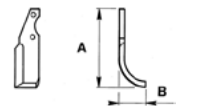
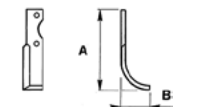
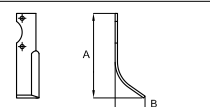
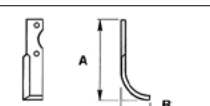
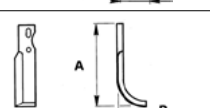
PASBO								
G14 - G84 Grottaglie	300010		A = 227 B = 80	C	50x6	10,5	73	490
G72-73-83-94 11 - 14 - 93	300020		A = 217 B = 77	C	40x6	10,5	73	420
G72	300020M2		A = 217 B = 77	C	45x6	10,5	73	480
G51-G21-G62-G2-HP5	300025		A = 195 B = 65	C	35x6	8,5	73	320
Asola	300034		A = 218 B = 77	C	40x6	10,5	68-80	430

Tutti i modelli sono di nostra produzione e non originali.
All models are of our manufacture and are not original.
Alle unsere Landwirtschaftliche erzeugnisse sind unsere produktion und sind nicht original.
Tous les modèles sont notre production et ne sont pas des produits d'origine.
Все модели нашего производства и не являются оригинальными.

N.B. Pesi e misure sopra descritti sono puramente indicativi.
N.B. The above weights and dimensions are given for reference only.
N.B. Die obengenannten Gewichte und Abmessungen sind richtungsweisend.
N.B. Les poids et les dimensions indiqués ci-dessus sont donnés à titre indicatif.
N.B. Указанные вес и размеры, являются ориентировочными.

© La riproduzione
anche parziale
del presente catalogo
è vietata.





Marca della macchina Machine brand name Marke der Maschine Marque de la machine Марка машины	Codice Nr. Ref. Nr. Re. Nr. Ref. Nr. Код №		Quote Dimensions Abmessungen Dimensions Размеры mm	Curvatura Curvature Krümmung Courbure Изгиб	Piatto Plate Platte Plaque Профиль mm	Fori Holes Löcher Trous Отверстия Ø mm	Interasse Center distance Achsenabstand Entraxe Расстояние Ø - Ø	Peso Weight Gewicht Poids Вес gr
Asola	300035		A = 218 B = 77	C	50x6	10,5	68-80	530
Asola	300036		A = 218 B = 77	C	45x6	10,5	68-80	480
G72	300037		A = 217 B = 77	C	50x6	10,5	73	530

PASQUALI

Nuova fresa 592/598	301002		A = 190 B = 90	SQ	60x6	12,5	42	510
V.T. Ax20/21 - 599	301003		A = 237 B = 80 C = 25	C	35x8	10,5	80	520
Nuova fresa 946	301005		A = 182 B = 88	C	60x6	12,5	42	520
914-588-934-923-912 500110/11	301009		A = 159 B = 53	C	50x6	10,5	32	335
901 - 591 500095/96	301010		A = 143 B = 50	C	50x6	10,5	32	310
592/917/598/946/956/ 959/596/491 500112/13	301011		A = 180 B = 88	C	60x6	12,5	42	480
557-917-922 500093/94	301012		A = 162 B = 88	C	60x6	12,5	42	450
532/938/495/498 500160/61	301014		A = 172 B = 50	C	25x5	8,5	68	170
938/490/496/499/402/ 404/406 532211/12	301019		A = 184 B = 80 C = 8	C	30x6	10,5	68	290
428 N.T. largo/ 478 - 532 NT 500098/99	301020		A = 145 B = 72 C = 30	C	50x6	10,5	40	380

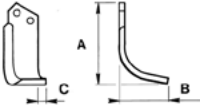
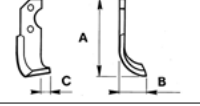
Marca della macchina Machine brand name Marke der Maschine Marque de la machine Марка машины	Codice Nr. Ref. Nr. Re. Nr. Ref. Nr. Код №	Quote Dimensions Abmessungen Dimensions Размеры mm	Curvatura Curvature Krümmung Courbure Изгиб	Piatto Plate Platte Plaque Профиль mm	Fori Holes Löcher Trous Отверстия Ø mm	Interasse Center distance Achsenabstand Entraxe Расстояние Ø - Ø	Peso Weight Gewicht Poids Вес gr
--	--	---	---	--	---	---	---

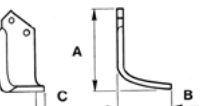
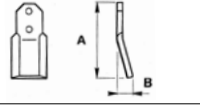
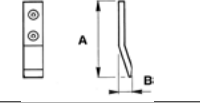
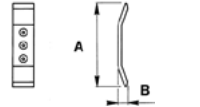
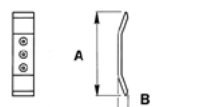
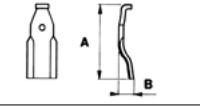
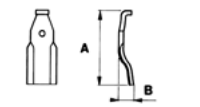
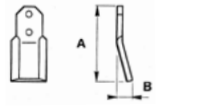
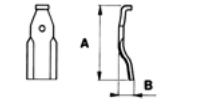
PEGORARO								
FORT PEGORARO								
TN-TB 1852/53	302005		A = 180 B = 135 C = 15	C	70x7	12,5	54	820
TL 3300/1	302007		A = 290 B = 85 C = 15	C	60x6	12,5	90	750
Tipo AC - AD 005378/79	302008		A = 206 B = 135 C = 15	SQ	80x8	14,5	57	1240
Tipo C-D 4585/86	302009		A = 206 B = 135 C = 15	C	80x8	14,5	57	1050
Coltello DL-LM 5333	302014		A = 180 B = 45	C	70x10	14,5	50	930
Vomerino per ancorotto corto	302016		A = 225 B = 45	—	70x18	13	66	2200
Vomere per ancora Drag da 70 3 fori 3814	302017		A = 430 B = 45	—	70x18	13	66	4175
Vomere per ancora Drag da 100 3715	302018		A = 405 B = 40	—	100x14	13	66	4400
Pegolama 1 foro Flangia spessore 12 006955	302022		A = 195 B = 45	—	60x10	16,5	—	820
Pegolama lungo	302042		A = 225 B = 45	—	60x10	16,5	—	920
Coltello DL-LM lungo	302028		A = 210 B = 23	—	70x10	14,5	50	1080
Pegolama 1 foro Flangia spessore 14 008600	302033		A = 205 B = 45	—	60x10	16,5	—	870



Marca della macchina Machine brand name Marke der Maschine Marque de la machine Марка машины	Codice Nr. Ref. Nr. Re. Nr. Ref. Nr. Код №	Quote Dimensions Abmessungen Dimensions Размеры mm	Curvatura Curvature Krümmung Courbure Изгиб	Piatto Plate Platte Plaque Профиль mm	Fori Holes Löcher Trous Отверстия Ø mm	Interasse Center distance Achsenabstand Entraxe Расстояние Ø - Ø	Peso Weight Gewicht Poids Вес gr
--	--	---	---	--	---	---	---

**PERUGINI
CONCEPT**

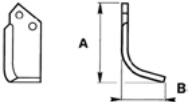
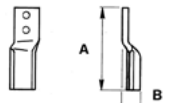
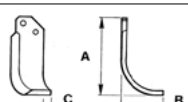
	304005		A = 195 B = 88	C	60x6	12,5	42	550
	304011		A = 202 B = 40	—	50x12	16,5	45	840
	304012		A = 192 B = 135 C = 15	C	80x6	14,5	56	845

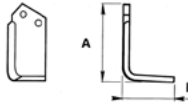

RANDI

Chieti 3500	318004		A = 160 B = 82	C	60x6	10,5	32	470
-------------	--------	---	-------------------	---	------	------	----	-----

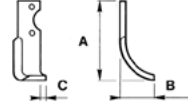
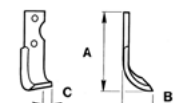
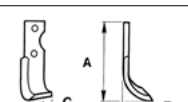
ROTECO

	321003		A = 200 B = 88 C = 13	C	45x6	10,5	66	460
	321005		A = 180 B = 75 C = 15	C	25x5	10,5	65	200
	321007		A = 200 B = 75 C = 15	C	35x5	10,5	65	290

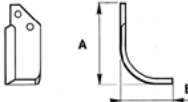
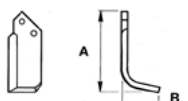
SEP

Motocoltivatore 2000-1300-1500 106163/64	331001		A = 140 B = 55	C	40x6	10,5	27	260
Motozappa 140 206448/49	331005		A = 175 B = 70	C	50x6	10,5	35	430
130-125-113 208062/63	331006		A = 217 B = 74	C	45x6	10,5	70	450

ZAPPETTE
Blades
Messern
Couteaux
Ножи



Marca della macchina Machine brand name Marke der Maschine Marque de la machine Марка машины	Codice Nr. Ref. Nr. Re. Nr. Ref. Nr. Код №		Quote Dimensions Abmessungen Dimensions Размеры mm	Curvatura Curvature Krümmung Courbure Изгиб	Piatto Plate Platte Plaque Профиль mm	Fori Holes Löcher Trous Отверстия Ø mm	Interasse Center distance Achsenabstand Entraxe Расстояние Ø - Ø	Peso Weight Gewicht Poids Вес gr
100-70-60 207843/44	331008		A = 200 B = 70	C	35x6	10,5	70	340
90-40-50-35 209376/77	331009		A = 188 B = 65	C	30x6	8,5	70	270
Motozappa S115-125 int./105 210398/99	331010		A = 195 B = 70	C	45x6	10,5	70	450
Motocoltivatore 1000 210578/79	331011		A = 170 B = 56 C = 20	C	25x6	8,5	55	200
SMART 212090/91A	331017		A = 170 B = 50 C = 15	C	25x5	8,5	55	200
S/506 - 113 215318/19	331025		A = 215 B = 74 C = 55	C	40x5	10,5	70	330
430/450 215667/68	331026		A = 211 B = 72 C = 60	C	40x4	8,5	70	280

S.I.C.M.A.
(MIGLIANICO)

ZLL-SB 4811281/82	332015		A = 174 B = 108 C = 12	C	60x6	12,5	42	540
CS 4811400/1	332020		A = 185 B = 115 C = 20	C	70x6	12,5	42	700
SM 4818222/23	332022		A = 190 B = 135 C = 15	C	80x7	14,5	55	970
SM 4818224/25	332023		A = 190 B = 135 C = 15	SQ	80x7	14,5	55	1020
ST-SD-HS 4812425/26	332024		A = 175 B = 135 C = 18	C	80x7	14,5	55	960
ST-SD-HS 48124427/28	332025		A = 175 B = 135 C = 18	SQ	80x7	14,5	55	1000



Tutti i modelli sono di nostra produzione e non originali.
All models are of our manufacture and are not original.
Alle unsere Landwirtschaftliche erzeugnisse sind unsere produktion und sind nicht original.
Tous les modèles sont notre production et ne sont pas des produits d'origine.
Все модели нашего производства и не являются оригинальными.

N.B. Pesi e misure sopra descritti sono puramente indicativi.
N.B. The above weights and dimensions are given for reference only.
N.B. Die obengenannten Gewichte und Abmessungen sind richtungsweisend.
N.B. Les poids et les dimensions indiqués ci-dessus sont donnés à titre indicatif.
N.B. Указанные вес и размеры, являются ориентировочными.

© La riproduzione
anche parziale
del presente catalogo
è vietata.

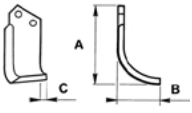
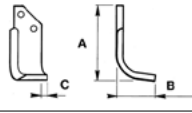
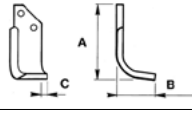
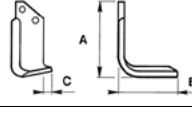
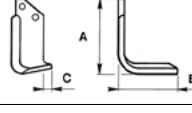
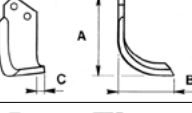
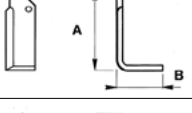
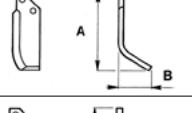
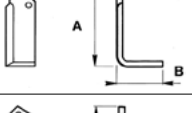

Marca della macchina Machine brand name Marke der Maschine Marque de la machine Марка машины	Codice Nr. Ref. Nr. Re. Nr. Ref. Nr. Код №	Quote Dimensions Abmessungen Dimensions Размеры mm	Curvatura Curvature Krümmung Courbure Изгиб	Piatto Plate Platte Plaque Профиль mm	Fori Holes Löcher Trous Отверстия Ø mm	Interasse Center distance Achsenabstand Entraxe Расстояние Ø - Ø	Peso Weight Gewicht Poids Вес gr
--	--	---	---	--	---	---	---

SOVEMA								
ST-STC-S-SE-SEC-SEC3 900111005/6	338001		A = 170 B = 113 C = 15	C	80x8	14,5	46	1040
SP-SPC-SE-SEC-S-SPS 900111001/2	338003		A = 187 B = 110 C = 7	C	70x7	12,5	46	780
SE-SEC-SEC3-S (160) 900111003/4	338003A		A = 187 B = 110 C = 7	C	70x7	14,5	46	780
SP-SPC-SE-SEC-S-SPS 900111007/8	338004		A = 158 B = 110 C = 5	SQ	70x7	12,5	46	840
SE-SEC-SEC3-S-ST-STC 900111009/10	338004A		A = 158 B = 110 C = 5	SQ	70x7	14,5	46	840
900111013/14	338007		A = 176 B = 102 C = 5	C	60x6	12,5	46	560
900111019/20	338008		A = 150 B = 110	SQ	60x6	12,5	46	650
Laser 9001110021/22	338010		A = 165 B = 85	C	50x6	10,5	35	430
Tipo lungo 900111017/18	338011		A = 190 B = 140 C = 15	SQ	80x8	14,5	46	1170
Tipo lungo S2 900111023/24	338012		A = 190 B = 140 C = 15	C	80x8	14,5	46	1100

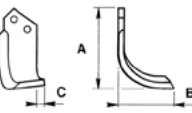
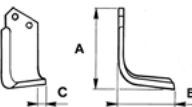
TORTELLA								
S1-T2-CLS 2985600/602	350009		A = 190 B = 110 C = 20	C	70x7	12,5	42	860
T5-T45 2985314/316	350013		A = 220 B = 148 C = 24	SQ	80x8	14,5	59	1360

ZAPPETTE

Blades

Messern

Couteaux

Ножи



Marca della macchina Machine brand name Marke der Maschine Marque de la machine Марка машины	Codice Nr. Ref. Nr. Re. Nr. Ref. Nr. Код №		Quote Dimensions Abmessungen Dimensions Размеры mm	Curvatura Curvature Krümmung Courbure Изгиб	Piatto Plate Platte Plaque Профиль mm	Fori Holes Löcher Trous Отверстия Ø mm	Interasse Center distance Achsenabstand Entraxe Расстояние Ø - Ø	Peso Weight Gewicht Poids Вес gr
T3-T4 2985204/206	350014		A = 184 B = 134 C = 20	C	80x8	14,5	56	1180
T3-T4 2985214/216	350015		A = 184 B = 134 C = 16	SQ	80x8	14,5	56	1230

TOSELLI

Vomere	351001		A = 235 B = 95	C	100x8	12,5	46	1000
Vomere	351002		A = 235 B = 95	C	100x10	12,5	46	1250

UNCINO

Uncino universale con asola	Uncino 01		A = 200 B = 40 C = 60	—	30x6	8,5	68-74	300
Asola	Uncino 01/A		A = 200 B = 40 C = 60	—	30x6	10,5	68-80	300
Uncino universale con asola	Uncino 02		A = 218 B = 40 C = 60	—	35x6	10,5	68-80	350
Asola	Uncino 03		A = 184 B = 39 C = 60	—	30x6	8,5	68-80	290

VALPADANA

VMC 10-12	358002		A = 146 B = 70	C	50x6	10,5	35	340
VMC 14 - VMC 160 102280/81	358003		A = 163 B = 78	C	50x6	10,5	35	380
VMC 14 - VMC 160	358004		A = 165 B = 85	SQ	50x6	10,5	35	430

Tutti i modelli sono di nostra produzione e non originali.
All models are of our manufacture and are not original.
Alle unsere Landwirtschaftliche erzeugnisse sind unsere produktion und sind nicht original.
Tous les modèles sont notre production et ne sont pas des produits d'origine.
Все модели нашего производства и не являются оригинальными.

N.B. Pesi e misure sopra descritti sono puramente indicativi.
N.B. The above weights and dimensions are given for reference only.
N.B. Die obengenannten Gewichte und Abmessungen sind richtungsweisend.
N.B. Les poids et les dimensions indiqués ci-dessus sont donnés à titre indicatif.
N.B. Указанные вес и размеры, являются ориентировочными.

© La riproduzione
anche parziale
del presente catalogo
è vietata.



Marca della macchina Machine brand name Marke der Maschine Marque de la machine Марка машины	Codice Nr. Ref. Nr. Re. Nr. Ref. Nr. Код №		Quote Dimensions Abmessungen Dimensions Размеры mm	Curvatura Curvature Krümmung Courbure Изгиб	Piatto Plate Platte Plaque Профиль mm	Fori Holes Löcher Trous Отверстия Ø mm	Interasse Center distance Achsenabstand Entraxe Расстояние Ø - Ø	Peso Weight Gewicht Poids Вес gr
VMC 15 103743/44	358005		A = 200 B = 80	C	50x6	10,5	35	430
VMC 18 4RM 20VT 112439/40	358010		A = 220 B = 96	C	60x6	10,5	45	620
VMC 8	358012		A = 140 B = 55	C	40x6	10,5	27	250
VMC 18 4RM20 NT	358018		A = 200 B = 95	C	60x6	10,5	45	590
VMC 150 114598/99	358021		A = 217 B = 74	C	45x6	10,5	70	450
VMC 8 lungo	358022		A = 160 B = 55	C	40x6	10,5	27	280
VMC 140 115915/16	358023		A = 200 B = 70	C	35x6	10,5	70	340
VMC 14 N.T.	358024		A = 174 B = 76	C	50x6	10,5	35	410

A stylized globe showing the outlines of continents. A banner is draped across the middle of the globe, containing the word "eurozappa" in a bold, lowercase, sans-serif font.

eurozappa

BULLONERIA SPECIALE PER ZAPPETTE

Special bolts and nuts for blades

Spezielle Schrauben für Messer

Boulonnerie pour couteaux

Специальные болты для ножей





BULLONERIA SPECIALE PER ZAPPETTE
Special bolts and nuts for blades
Spezielle Schrauben für Messer
Boulonnerie pour couteaux
Специальные болты для ножей

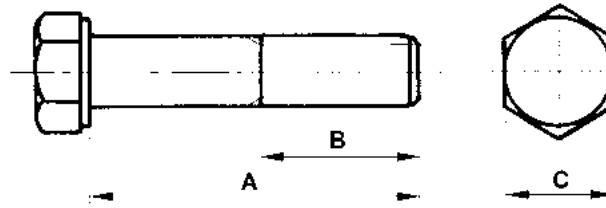

Descrizione Description Beschreibung Description Описание	Codice Nr. Ref. Nr. Re. Nr. Ref. Nr. Код №	Quote Dimensions Abmessungen Dimensions Размеры mm	Passo vite Screw pitch Schraubensteigung Pas de vis Шар резьбы	Peso Weight Gewicht Poids Вес gr	Confezione Package Verpackungen Confection Упаковка, шт.
Vite completa 8×30 con dado e grower	656004	A = 30 B = 24 C = 13	Passo 1,25 classe 8.8	19	150 pz.
Vite completa 10×30 con dado e grower	656008	A = 30 B = 16 C = 17	Passo 1,5 classe 8.8	30	150 pz.
Vite completa 12×35 con dado e grower	656012	A = 35 B = 18 C = 19	Passo 1,5 classe 8.8	45	200 pz.
Vite completa 14×40 con dado e grower	656016	A = 40 B = 20 C = 22	Passo 1,5 classe 8.8	70	150 pz.
Vite completa 7/16 (11,5) con dado e grower	656020	A = 31 B = 15 C = 17	Passo UNF classe 8.8	30	150 pz.
Vite completa 1/2 (13,5) con dado e grower	656024	A = 38 B = 23 C = 19	Passo UNF classe 8.8	50	150 pz.

Tutti i modelli sono di nostra produzione e non originali.
 All models are of our manufacture and are not original.
 Alle unsere Landwirtschaftliche erzeugnisse sind unsere produktion und sind nicht original.
 Tous les modèles sont notre production et ne sont pas des produits d'origine.
 Все модели нашего производства и не являются оригинальными.

N.B. Pesi e misure sopra descritti sono puramente indicativi.
 N.B. The above weights and dimensions are given for reference only.
 N.B. Die obengenannten Gewichte und Abmessungen sind richtungsweisend.
 N.B. Les poids et les dimensions indiqués ci-dessus sont donnés à titre indicatif.
 N.B. Указанные вес и размеры, являются ориентировочными.

© La riproduzione
 anche parziale
 del presente catalogo
 è vietata.





eurozappa

COLTELLI PER SCAVAFOSSE
Blades des trenchers
Messer für Grabenfräse
Couteaux pour fossoyeuses
Ножи для траншеекопателей







COLTELLI PER SCAVAFOSSI
Blades des trenchers
Messer für Grabenfräse
Couteaux pour fossoyeuses
Ножи для траншеекопателей

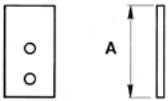

Descrizione Description Beschreibung Description Описание	Codice Nr. Ref. Nr. Re. Nr. Ref. Nr. Код №	Quote Dimensions Abmessungen Dimensions Размеры mm	Piatto Plate Platte Plaque Профиль mm	Fori Holes Löcher Trous Отверстия Ø mm	Interasse Center distance Achsenabstand Entraxe Расстояние Ø - Ø	Peso Weight Gewicht Poids Вес gr
---	--	---	--	---	---	---

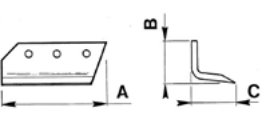
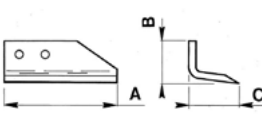
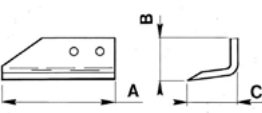
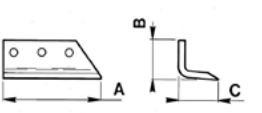
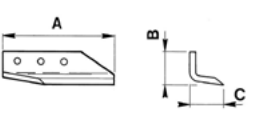
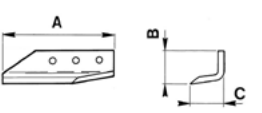
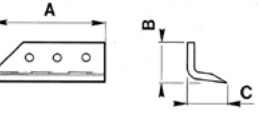
DONDI							
Dente DMR 25 25-35/25-35B/25S	515001		A = 90	50x10	10,5	30	330
Dente DMR 45 45 PA-65B/MR 45-55B DBR 65R-75-90-95	515002		A = 120	60x12	12,5	50	650
Coltello interno 25A per DMR 25/35-35B/25S	515003		A = 180 B = 60 C = 62	90x8	12,5	50	850
Coltello esterno S25B DX per DMR 25/35-35B/25S	515004		A = 210 B = 60 C = 66	90x8	12,5	50	1030
Coltello esterno S5C SX per DMR 25/35-35B/25S	515004A		A = 210 B = 60 C = 66	90x8	12,5	50	1030
Coltello esterno S45A per DMR 45-45PA/ MR 45-55B	515005		A = 210 B = 60 C = 60	90x8	14,5	65	1000
Coltello esterno S45B DX per DMR 45-45PA/ MR 45-55B/DBR 65/75	515006		A = 310 B = 68 C = 73	100x8	14,5	60	1650
Coltello esterno S45C SX per DMR 65/75	515006A		A = 310 B = 68 C = 73	100x8	14,5	60	1650
Coltello interno S65A per DMR 65B	515007		A = 250 B = 65 C = 65	100x8	14,5	65	1380

Tutti i modelli sono di nostra produzione e non originali.
 All models are of our manufacture and are not original.
 Alle unsere Landwirtschaftliche erzeugnisse sind unsere produktion und sind nicht original.
 Tous les modèles sont notre production et ne sont pas des produits d'origine.
 Все модели нашего производства и не являются оригинальными.

N.B. Pesi e misure sopra descritti sono puramente indicativi.
 N.B. The above weights and dimensions are given for reference only.
 N.B. Die obengenannten Gewichte und Abmessungen sind richtungsweisend.
 N.B. Les poids et les dimensions indiqués ci-dessus sont donnés à titre indicatif.
 N.B. Указанные вес и размеры, являются ориентировочными.

© La riproduzione
 anche parziale
 del presente catalogo
 è vietata.

COLTELLI PER SCAVAFOSSI
Blades des trenchers
Messer für Grabenfräse
Couteaux pour fossoyeuses
Ножи для траншеекопателей



Descrizione Description Beschreibung Description Описание	Codice Nr. Ref. Nr. Re. Nr. Ref. Nr. Код №		Quote Dimensions Abmessungen Dimensions Размеры mm	Piatto Plate Platte Plaque Профиль mm	Fori Holes Löcher Trous Отверстия Ø mm	Interasse Center distance Achsenabstand Entraxe Расстояние Ø - Ø	Peso Weight Gewicht Poids Вес gr
Coltello esterno S65B DX per DMR 65B/DBR 90/95	515008		A = 340 B = 65 C = 68	100x8	14,5	60	1800
Coltello esterno S65C SX per DMR 90/95	515008A		A = 340 B = 65 C = 68	100x8	14,5	60	1800
Coltello disco DMR 25/45	515010		A = 210 B = 26	80x7	12,5	60	760
Drenag	515016		A = 255 B = 65	70x10	14,5	50-56	1500
DMR 85B/75B Coltello disco 607021	515023		A = 235 B = 30	90x8	12,5	50	1260
Dente piegato 607044/45 DESTRO	515026		A = 145 B = 45	60x10	10,5	30	260
Unghietta DBR 607040/41 DESTRO	515027		A = 158 B = 50	70x12	12,5	50	360
Dente DMR25NLF 607027	515032		A = 90 B = 40	50x10	10,5	30	350

KVERNELAND

Zappine per AFR2R-AFR/O-OS 3000071	535001		A = 90 B = 34	40x10	12,5	27	230
---	--------	--	------------------	-------	------	----	-----

COLTELLI PER SCAVAFOSSI
Blades des trenchers
Messer für Grabenfräse
Couteaux pour fossoyeuses
Ножи для траншеекопателей

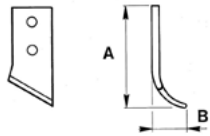
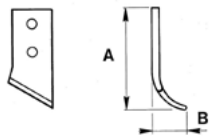
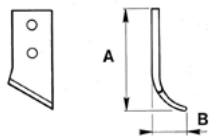
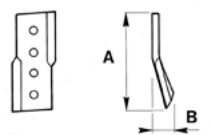
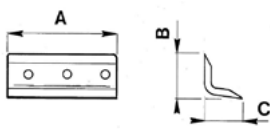
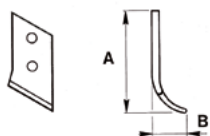
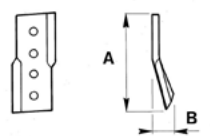
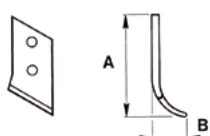

Descrizione Description Beschreibung Description Описание	Codice Nr. Ref. Nr. Re. Nr. Ref. Nr. Код №		Quote Dimensions Abmessungen Dimensions Размеры mm	Piatto Plate Platte Plaque Профиль mm	Fori Holes Löcher Trous Отверстия Ø mm	Interasse Center distance Achsenabstand Entraxe Расстояние Ø - Ø	Peso Weight Gewicht Poids Вес gr
Zappine per AFR2R-AFR/O-OS 3000072	535002		A = 94 B = 35	40x10	12,5	27	260
Zappine per AFR2R-AFR/O-OS 3000073	535003		A = 100 B = 36	40x10	12,5	27	270
Zappine per AFR2R-AFR/O-OS 3000074	535004		A = 102 B = 39	40x10	12,5	27	250
Coltello laterale AFR/O-OS 3000082	535006		A = 224 B = 48	60x10	14,5	60	890
Coltello angolare AFR/OS3C 3200081	535008		A = 265 B = 68 C = 68	100x10	14,5	88	1900
Zappine per AFR-2G DX/SX 3600071/72	535017		A = 148 B = 45	70x10	14,5	30	600
Coltello laterale DESTRO biruota 3900081	535022		A = 235 B = 40	70x10	15	50	1100
Zappine per AFR60 DX/SX 4201071/72	535024		A = 105 B = 42	70x12	14,5	30	550

Tutti i modelli sono di nostra produzione e non originali.
 All models are of our manufacture and are not original.
 Alle unsere Landwirtschaftliche erzeugnisse sind unsere produktion und sind nicht original.
 Tous les modèles sont notre production et ne sont pas des produits d'origine.
 Все модели нашего производства и не являются оригинальными.

N.B. Pesi e misure sopra descritti sono puramente indicativi.
 N.B. The above weights and dimensions are given for reference only.
 N.B. Die obengenannten Gewichte und Abmessungen sind richtungsweisend.
 N.B. Les poids et les dimensions indiqués ci-dessus sont donnés à titre indicatif.
 N.B. Указанные вес и размеры, являются ориентировочными.

© La riproduzione
 anche parziale
 del presente catalogo
 è vietata.





eurozappa

DENTI PER ERPICE ROTANTE
Tines for rotary harrows
Kreiseleggenzinken
Dents pour herses
Зубья ротационной бороны





Un pezzo guardato dall'alto verso il basso a rotazione **ANTIORARIA**, per convenzione è **SINISTRO**.

A piece viewed from top to bottom with **ANTI-CLOCKWISE** rotation, conventionally it's **LEFT HAND**.



Un pezzo guardato dall'alto verso il basso a rotazione **ORARIA**, per convenzione è **DESTRO**.

A piece viewed from top to bottom with **CLOCKWISE** rotation, conventionally it's **RIGHT HAND**.

DENTI PER ERPICE ROTANTE
Tines for rotary harrows
Kreiseleggenzinken
Dents pour herses
Зубья ротационной бороны



Marca della macchina Machine brand name Marke der Maschine Marque de la machine Марка машины	Tipo e codice originale Type and original code Typ original hersteller Type et code d'origine Тип и оригинальный код	Codice Nr. Ref. Nr. Re. Nr. Ref. Nr. Код №	Marca della macchina Machine brand name Marke der Maschine Marque de la machine Марка машины	Tipo e codice originale Type and original code Typ original hersteller Type et code d'origine Тип и оригинальный код	Codice Nr. Ref. Nr. Re. Nr. Ref. Nr. Код №
--	--	--	--	--	--

RICAMBIO NON ORIGINALE PER AGRAM	SIMOS 100x15	106001	RICAMBIO NON ORIGINALE PER ALPEGO	DH 110x15	113008
		gr 2900		D03000 / D03001	gr 2700

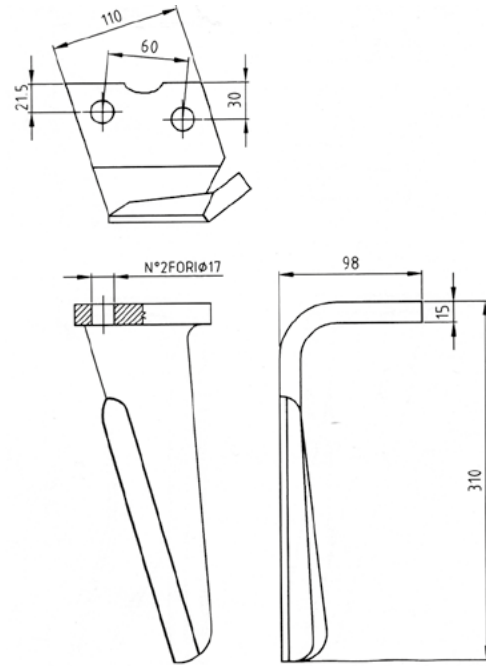
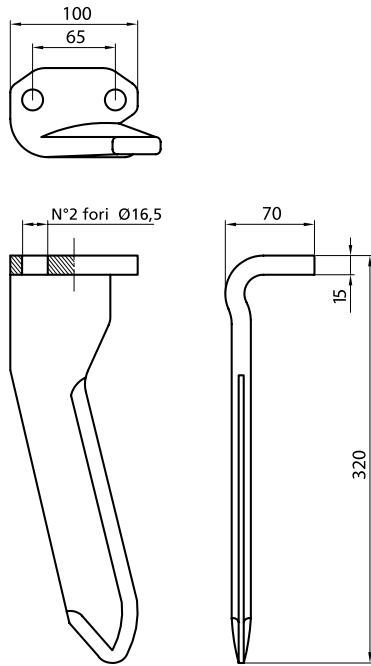

RICAMBIO NON ORIGINALE PER ALPEGO	DD3 / DF4 100x12	113009	RICAMBIO NON ORIGINALE PER ALPEGO	ATTACCO RAPIDO 100x15	113014
	D01270 / D01271	gr 2130		D05650 / D05651	gr 2790

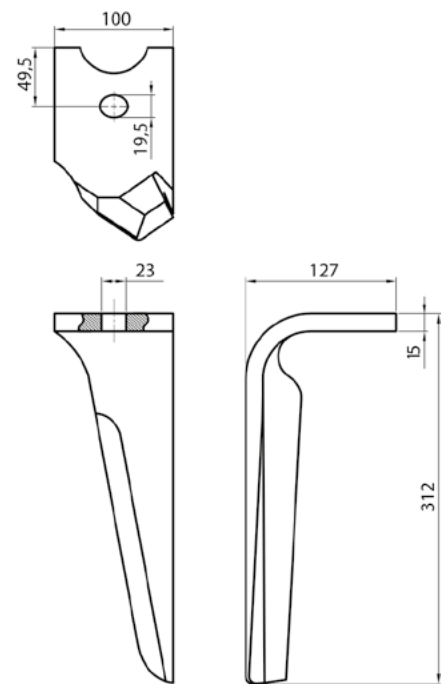
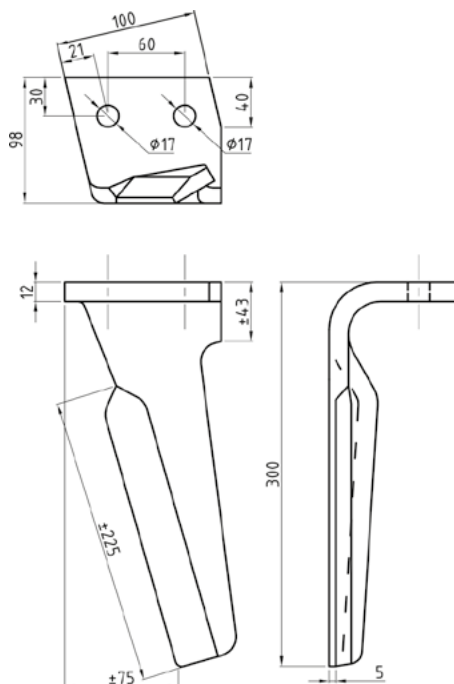

Tutti i modelli sono di nostra produzione e non originali.
 All models are of our manufacture and are not original.
 Alle unsere Landwirtschaftliche erzeugnisse sind unsere produktion und sind nicht original.
 Tous les modèles sont notre production et ne sont pas des produits d'origine.
 Все модели нашего производства и не являются оригинальными.

N.B. Pesi e misure sopra descritti sono puramente indicativi.
 N.B. The above weights and dimensions are given for reference only.
 N.B. Die obengenannten Gewichte und Abmessungen sind richtungsweisend.
 N.B. Les poids et les dimensions indiqués ci-dessus sont donnés à titre indicatif.
 N.B. Указанные вес и размеры, являются ориентировочными.

© La riproduzione anche parziale del presente catalogo è vietata.

DENTI PER ERPICE ROTANTE
Tines for rotary harrows
Kreiseleggenzinken
Dents pour herses
Зубья ротационной бороны



Marca della macchina
 Machine brand name
 Marke der Maschine
 Marque de la machine
 Марка машины

Tipo e codice originale
 Type and original code
 Typ original hersteller
 Type et code d'origine
 Тип и оригинальный код

Codice Nr.
 Ref. Nr.
 Re. Nr.
 Ref. Nr.
 Код №

Marca della macchina
 Machine brand name
 Marke der Maschine
 Marque de la machine
 Марка машины

Tipo e codice originale
 Type and original code
 Typ original hersteller
 Type et code d'origine
 Тип и оригинальный код

Codice Nr.
 Ref. Nr.
 Re. Nr.
 Ref. Nr.
 Код №

RICAMBIO NON ORIGINALE PER ALPEGO	RG/DG 100x14	113017	RICAMBIO NON ORIGINALE PER ALPEGO	RH 110x18	113018
	D06700 / D06701	gr 2510		D07400 / D07401	gr 3570

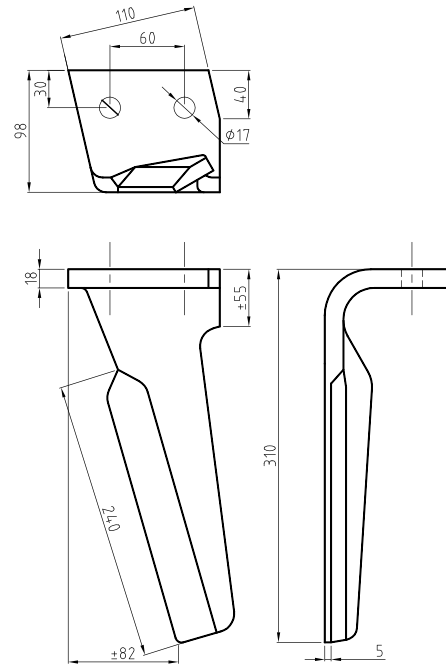
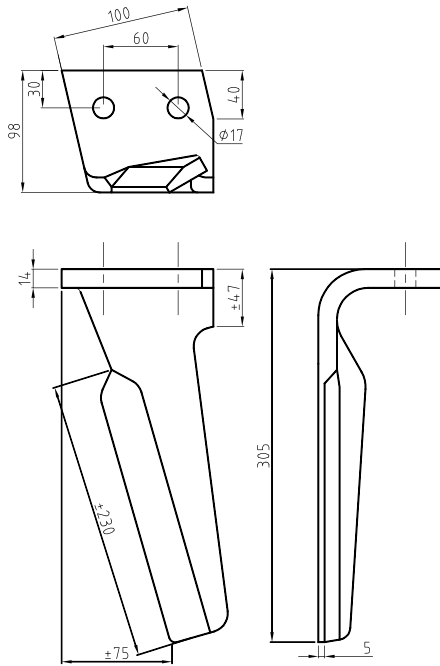

RICAMBIO NON ORIGINALE PER AMAZONE	E/28B DIETRO V.T.	400002	RICAMBIO NON ORIGINALE PER AMAZONE	KE 02 60x15	400007
	63021	gr 1600		951011 / 951012	gr 2210

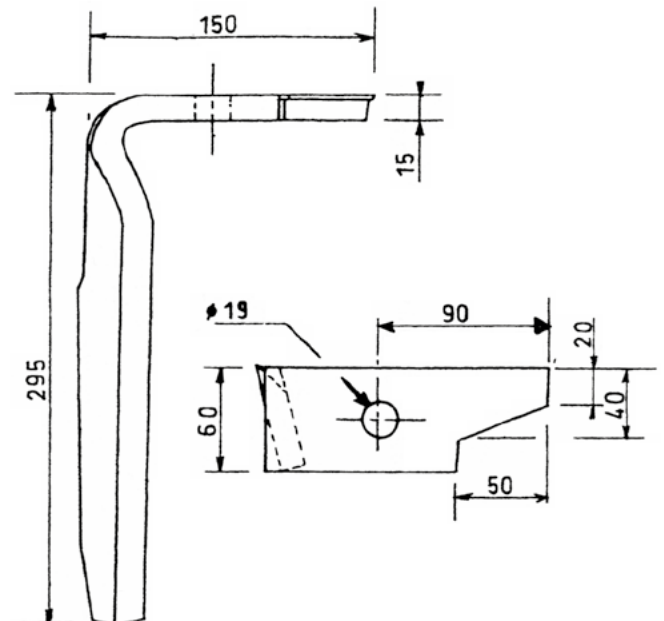
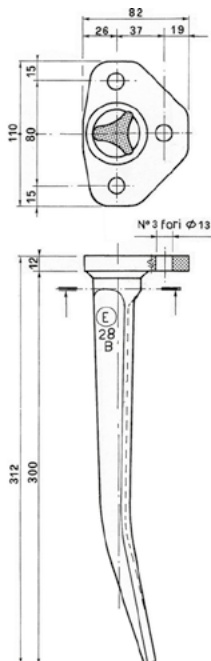

DENTI PER ERPICE ROTANTE
Tines for rotary harrows
Kreiseleggenzinken
Dents pour herses
Зубья ротационной бороны



Marca della macchina Machine brand name Marke der Maschine Marque de la machine Марка машины	Tipo e codice originale Type and original code Typ original hersteller Type et code d'origine Тип и оригинальный код	Codice Nr. Ref. Nr. Re. Nr. Ref. Nr. Код №	Marca della macchina Machine brand name Marke der Maschine Marque de la machine Марка машины	Tipo e codice originale Type and original code Typ original hersteller Type et code d'origine Тип и оригинальный код	Codice Nr. Ref. Nr. Re. Nr. Ref. Nr. Код №
--	--	--	--	--	--

RICAMBIO NON ORIGINALE PER AMAZONE	CULTIMIX 120x15	400008	RICAMBIO NON ORIGINALE PER AMAZONE	DENTE 120x10	400009 400010
	6574300 / 6575300	gr 3000			

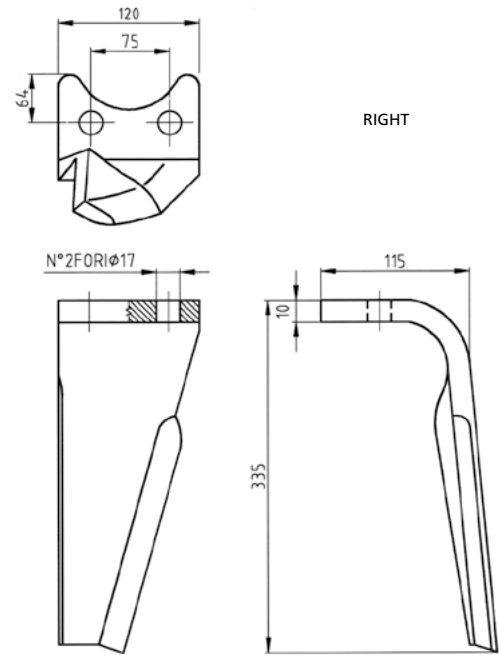
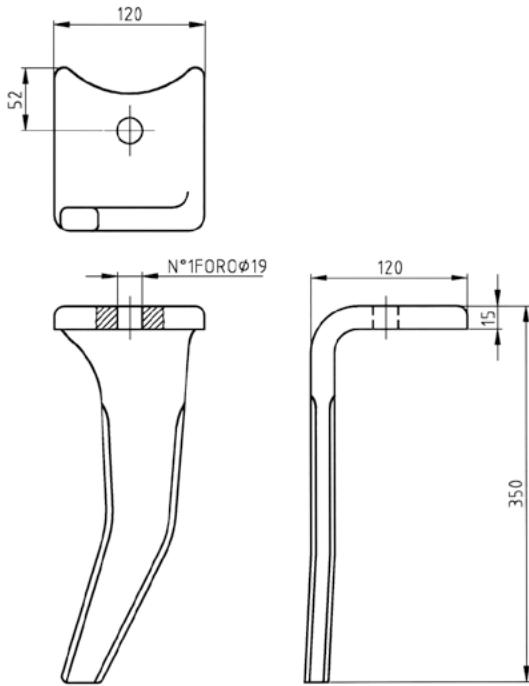

RICAMBIO NON ORIGINALE PER AMAZONE	DENTE 130x12	400011 400012	RICAMBIO NON ORIGINALE PER AMAZONE	60x18	400013
	6807400 / 6808400	gr 2900			954426 / 954427

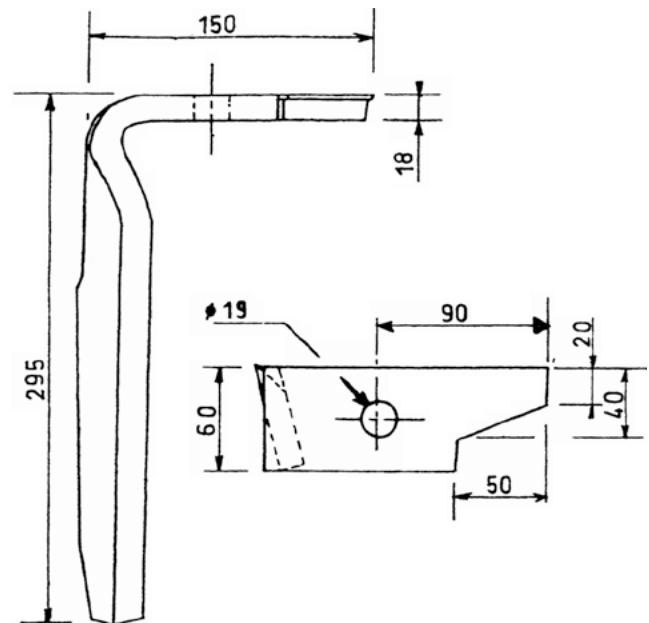
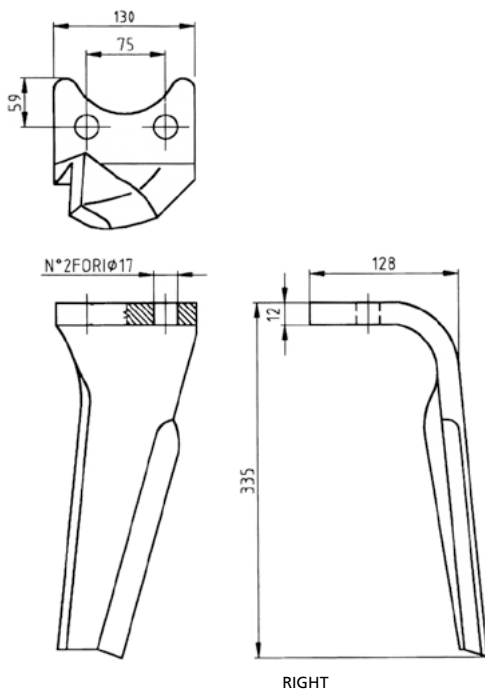

Tutti i modelli sono di nostra produzione e non originali.
 All models are of our manufacture and are not original.
 Alle unsere Landwirtschaftliche erzeugnisse sind unsere produktion und sind nicht original.
 Tous les modèles sont notre production et ne sont pas des produits d'origine.
 Все модели нашего производства и не являются оригинальными.

N.B. Pesi e misure sopra descritti sono puramente indicativi.
 N.B. The above weights and dimensions are given for reference only.
 N.B. Die obengenannten Gewichte und Abmessungen sind richtungsweisend.
 N.B. Les poids et les dimensions indiqués ci-dessus sont donnés à titre indicatif.
 N.B. Указанные вес и размеры, являются ориентировочными.

© La riproduzione
 anche parziale
 del presente catalogo
 è vietata.

DENTI PER ERPICE ROTANTE
Tines for rotary harrows
Kreiseleggenzinken
Dents pour herses
Зубья ротационной бороны



Marca della macchina Machine brand name Marke der Maschine Marque de la machine Марка машины	Tipo e codice originale Type and original code Typ original hersteller Type et code d'origine Тип и оригинальный код	Codice Nr. Ref. Nr. Re. Nr. Ref. Nr. Код №	Marca della macchina Machine brand name Marke der Maschine Marque de la machine Марка машины	Tipo e codice originale Type and original code Typ original hersteller Type et code d'origine Тип и оригинальный код	Codice Nr. Ref. Nr. Re. Nr. Ref. Nr. Код №
--	--	--	--	--	--

RICAMBIO NON ORIGINALE PER AMAZONE	CULTIMIX LARGO 120x15	400014	RICAMBIO NON ORIGINALE PER AMAZONE	CULTIMIX 120x15	400015
	967495 \ 967496	gr 3660		962337 / 962338	gr 3800

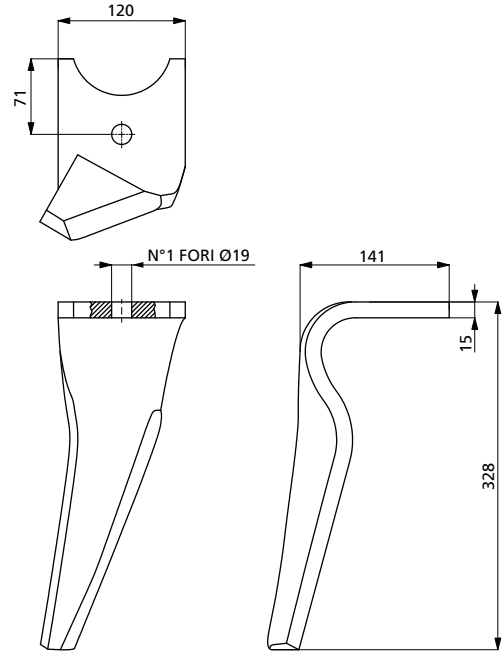
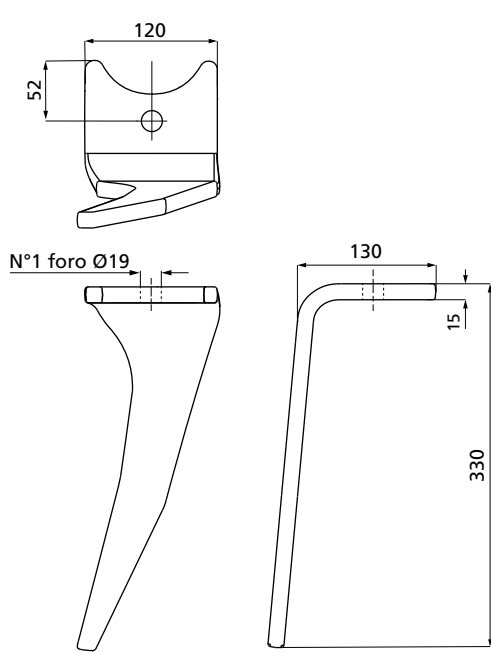

RICAMBIO NON ORIGINALE PER BREVIGLIERI	DENTE 100x12	134032	RICAMBIO NON ORIGINALE PER BREVIGLIERI	DENTE 90x12	134053
	88310	gr 2000		0177401 / 0177402	gr 3680

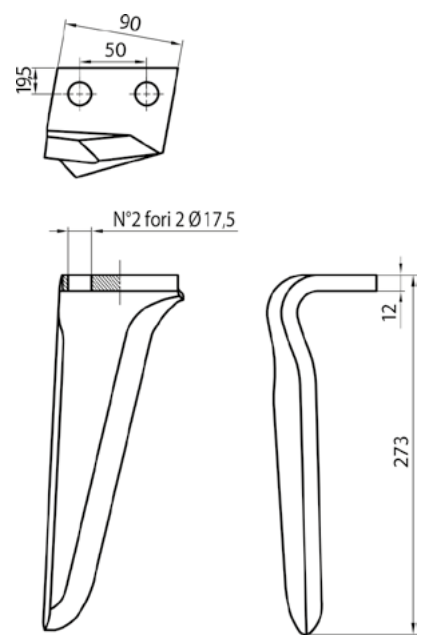
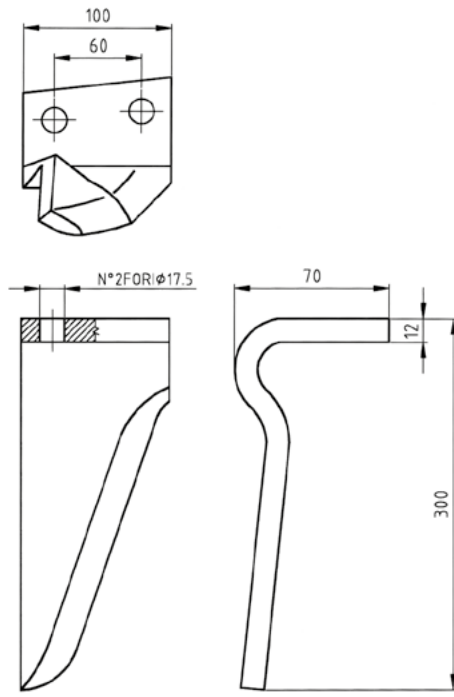

DENTI PER ERPICE ROTANTE

Tines for rotary harrows

Kreiseleggenzinken

Dents pour herses

Зубья ротационной бороны



Marca della macchina Machine brand name Marke der Maschine Marque de la machine Марка машины	Tipo e codice originale Type and original code Typ original hersteller Type et code d'origine Тип и оригинальный код	Codice Nr. Ref. Nr. Re. Nr. Ref. Nr. Код №	Marca della macchina Machine brand name Marke der Maschine Marque de la machine Марка машины	Tipo e codice originale Type and original code Typ original hersteller Type et code d'origine Тип и оригинальный код	Codice Nr. Ref. Nr. Re. Nr. Ref. Nr. Код №
--	--	--	--	--	--

RICAMBIO NON ORIGINALE PER BREVIGLIERI	DENTE 100x15	134057	RICAMBIO NON ORIGINALE PER CARRARO	DENTE 90x14	148020
	60184 / 60185	gr 2400		155216 / 155217	gr 2082

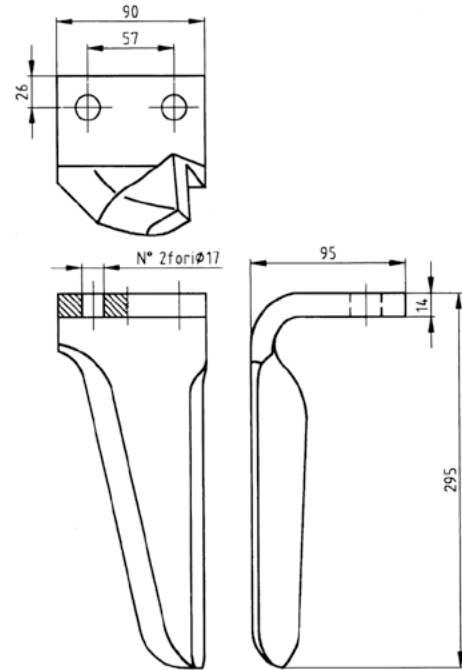
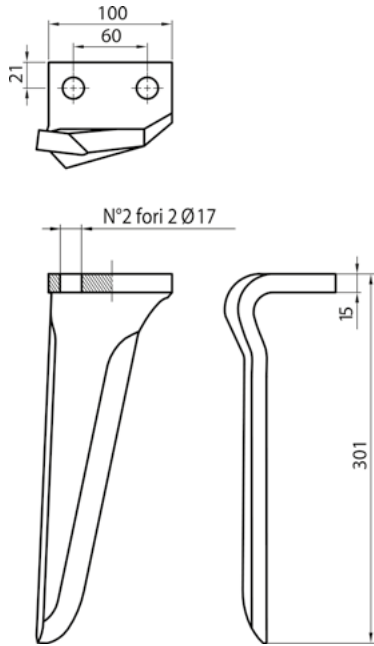

RICAMBIO NON ORIGINALE PER CELLI	PROTEZIONE 100x6	153029	RICAMBIO NON ORIGINALE PER CELLI	PROTEZIONE 120x6	153030
	622717	gr 440		622607	gr 560

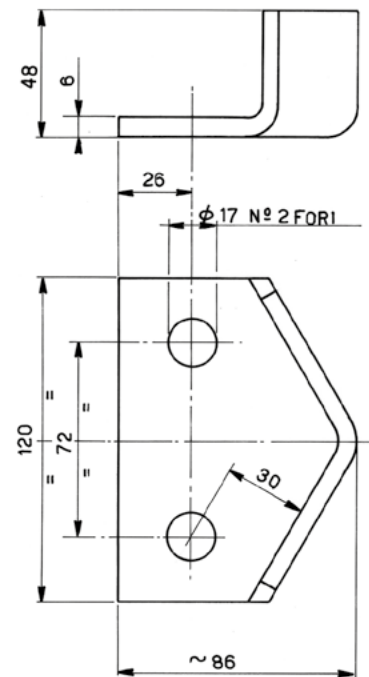
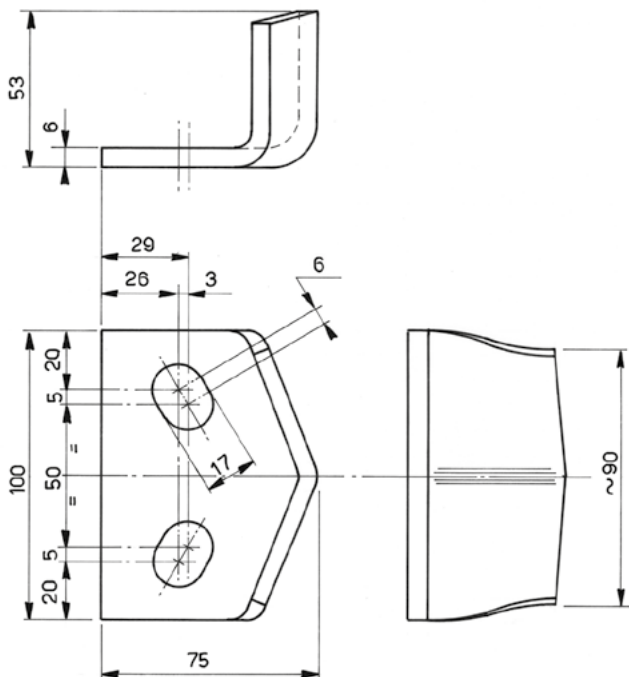

Tutti i modelli sono di nostra produzione e non originali.
 All models are of our manufacture and are not original.
 Alle unsere Landwirtschaftliche erzeugnisse sind unsere produktion und sind nicht original.
 Tous les modèles sont notre production et ne sont pas des produits d'origine.
 Все модели нашего производства и не являются оригинальными.

N.B. Pesi e misure sopra descritti sono puramente indicativi.
 N.B. The above weights and dimensions are given for reference only.
 N.B. Die obengenannten Gewichte und Abmessungen sind richtungsweisend.
 N.B. Les poids et les dimensions indiqués ci-dessus sont donnés à titre indicatif.
 N.B. Указанные вес и размеры, являются ориентировочными.

© La riproduzione anche parziale del presente catalogo è vietata.

DENTI PER ERPICE ROTANTE
Tines for rotary harrows
Kreiseleggenzinken
Dents pour herse
Зубья ротационной бороны



Marca della macchina
 Machine brand name
 Marke der Maschine
 Marque de la machine
 Марка машины

Tipo e codice originale
 Type and original code
 Typ original hersteller
 Type et code d'origine
 Тип и оригинальный код

Codice Nr.
 Ref. Nr.
 Re. Nr.
 Ref. Nr.
 Код №

Marca della macchina
 Machine brand name
 Marke der Maschine
 Marque de la machine
 Марка машины

Tipo e codice originale
 Type and original code
 Typ original hersteller
 Type et code d'origine
 Тип и оригинальный код

Codice Nr.
 Ref. Nr.
 Re. Nr.
 Ref. Nr.
 Код №

RICAMBIO NON ORIGINALE PER CELLI	DENTE 90x12	153031	RICAMBIO NON ORIGINALE PER CELLI	120x15 N.T A TRE FORI	153033A
	622715 / 622716	gr 1750		622603 / 622604	gr 2700

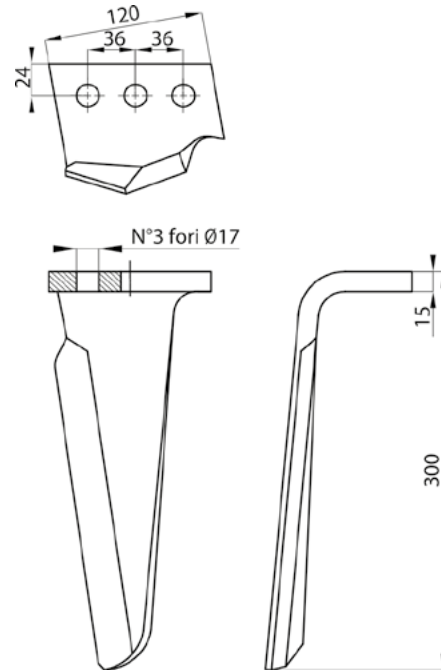
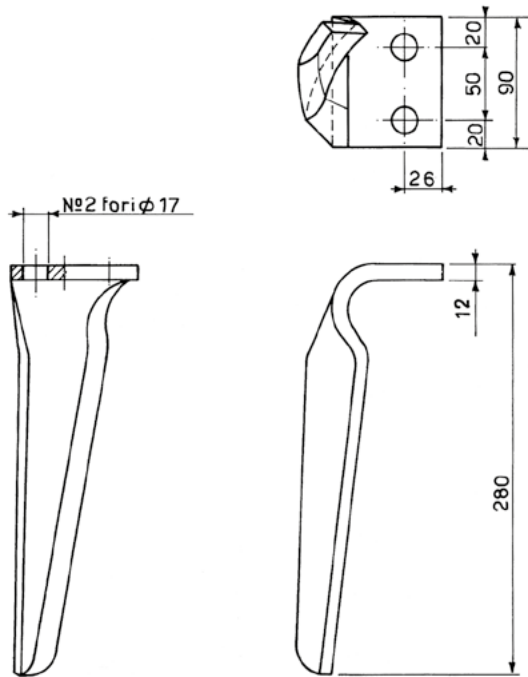

RICAMBIO NON ORIGINALE PER CELLI	E/2B CONICO CORTO	408001	RICAMBIO NON ORIGINALE PER CELLI	DENTE QUADRO 30x30	408005
		gr 1120		422538	gr 1050

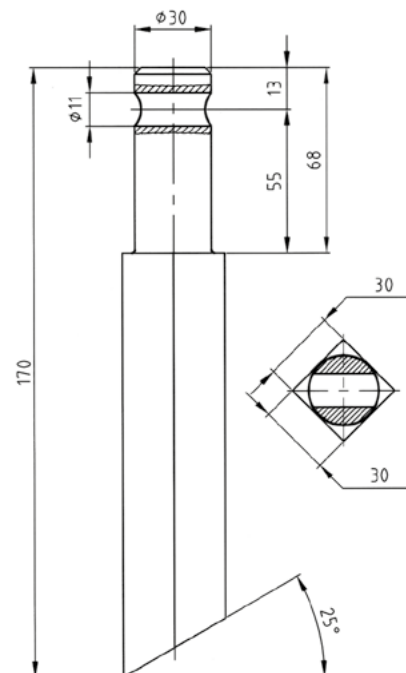
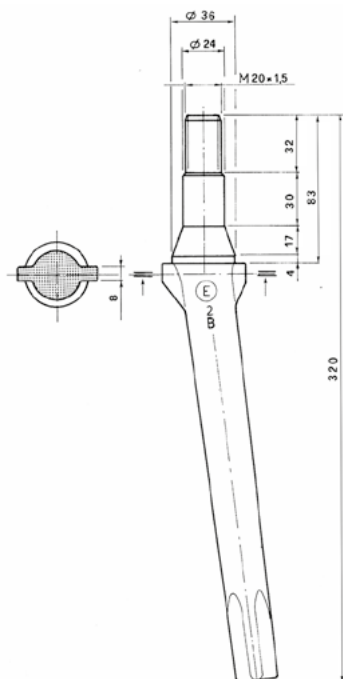

DENTI PER ERPICE ROTANTE
Tines for rotary harrows
Kreiseleggenzinken
Dents pour herses
Зубья ротационной бороны



Marca della macchina Machine brand name Marke der Maschine Marque de la machine Марка машины	Tipo e codice originale Type and original code Typ original hersteller Type et code d'origine Тип и оригинальный код	Codice Nr. Ref. Nr. Re. Nr. Ref. Nr. Код №	Marca della macchina Machine brand name Marke der Maschine Marque de la machine Марка машины	Tipo e codice originale Type and original code Typ original hersteller Type et code d'origine Тип и оригинальный код	Codice Nr. Ref. Nr. Re. Nr. Ref. Nr. Код №
--	--	--	--	--	--

RICAMBIO NON ORIGINALE PER CELLI	QUADRO 30x30	408007	RICAMBIO NON ORIGINALE PER CELLI	MAXI 100x18x320	153057
	422539	gr 1200		622613 / 622614	gr 2100

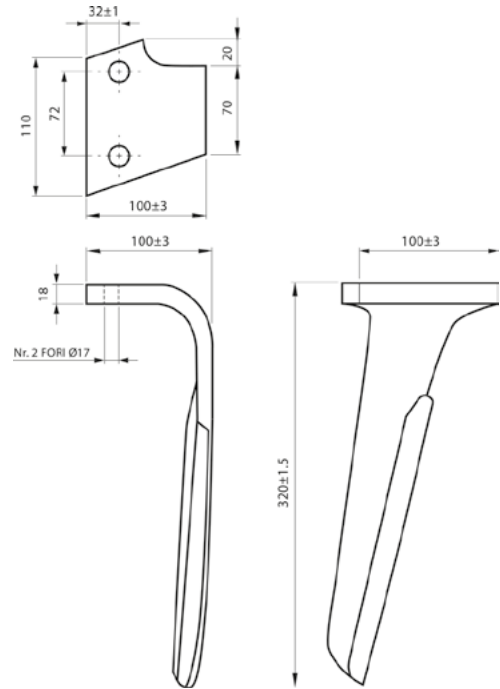
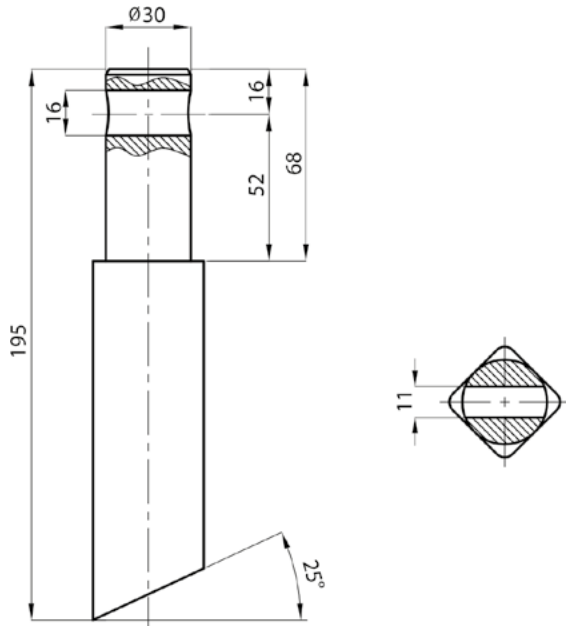

RICAMBIO NON ORIGINALE PER DOWDESWEL	110x15	410001	RICAMBIO NON ORIGINALE PER DOWDESWEL	SPIKE	410002
		gr 3150			gr 3200

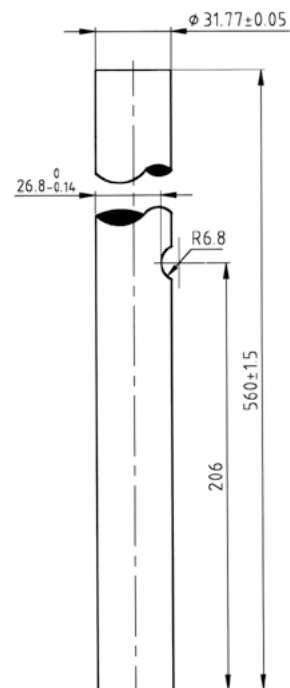
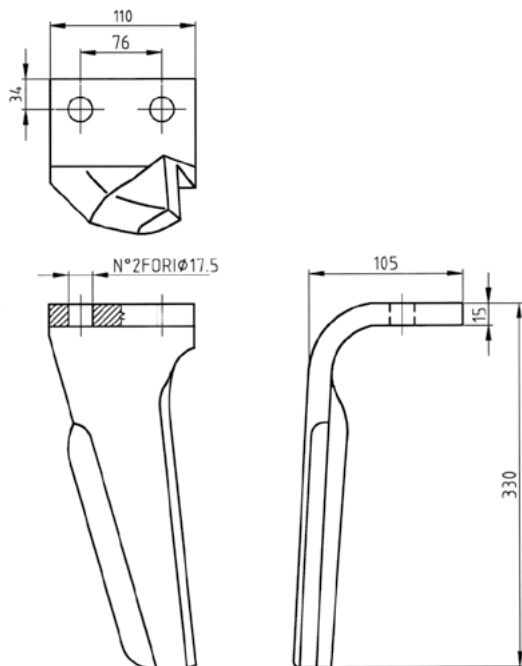

Tutti i modelli sono di nostra produzione e non originali.
 All models are of our manufacture and are not original.
 Alle unsere Landwirtschaftliche erzeugnisse sind unsere produktion und sind nicht original.
 Tous les modèles sont notre production et ne sont pas des produits d'origine.
 Все модели нашего производства и не являются оригинальными.

N.B. Pesi e misure sopra descritti sono puramente indicativi.
 N.B. The above weights and dimensions are given for reference only.
 N.B. Die obengenannten Gewichte und Abmessungen sind richtungsweisend.
 N.B. Les poids et les dimensions indiqués ci-dessus sont donnés à titre indicatif.
 N.B. Указанные вес и размеры, являются ориентировочными.

© La riproduzione anche parziale del presente catalogo è vietata.

DENTI PER ERPICE ROTANTE
Tines for rotary harrows
Kreiseleggenzinken
Dents pour herses
Зубья ротационной бороны



Marca della macchina Machine brand name Marke der Maschine Marque de la machine Марка машины	Tipo e codice originale Type and original code Typ original hersteller Type et code d'origine Тип и оригинальный код	Codice Nr. Ref. Nr. Re. Nr. Ref. Nr. Код №	Marca della macchina Machine brand name Marke der Maschine Marque de la machine Марка машины	Tipo e codice originale Type and original code Typ original hersteller Type et code d'origine Тип и оригинальный код	Codice Nr. Ref. Nr. Re. Nr. Ref. Nr. Код №
--	--	--	--	--	--

RICAMBIO NON ORIGINALE PER EMY	DENTE 100x15	172001	RICAMBIO NON ORIGINALE PER EMY	100x15	172003
	2901270 / 2901271	gr 2550		2901268 / 2901269	gr 2430

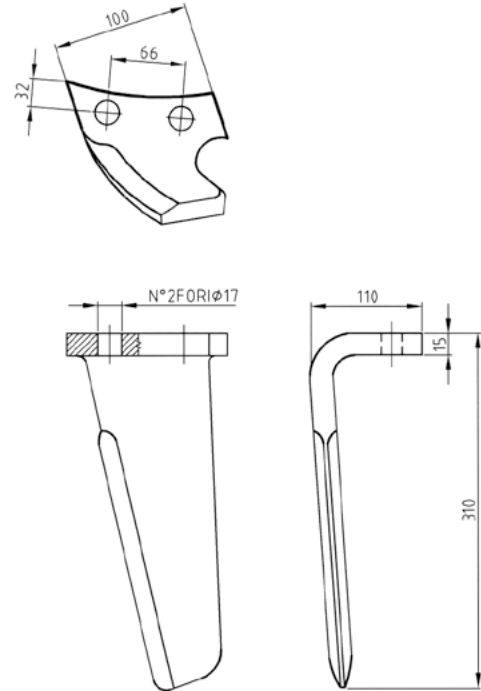
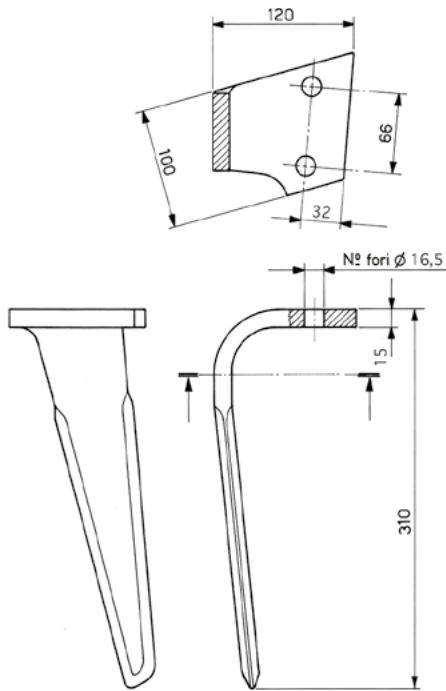

RICAMBIO NON ORIGINALE PER FALC	FOX 90x12	181010	RICAMBIO NON ORIGINALE PER FALC	QUADRO	181042
	512075 / 512076	gr 1750		240131	gr 650

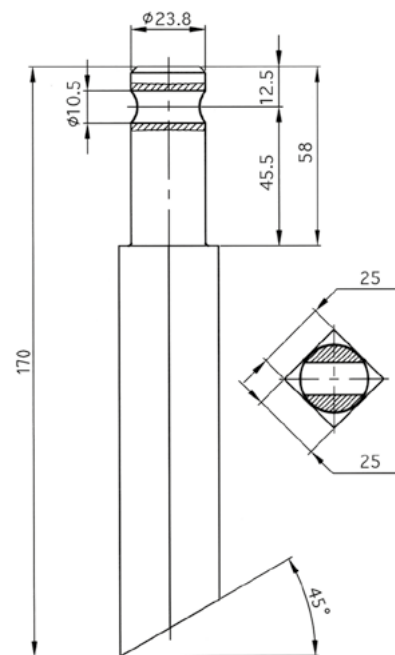
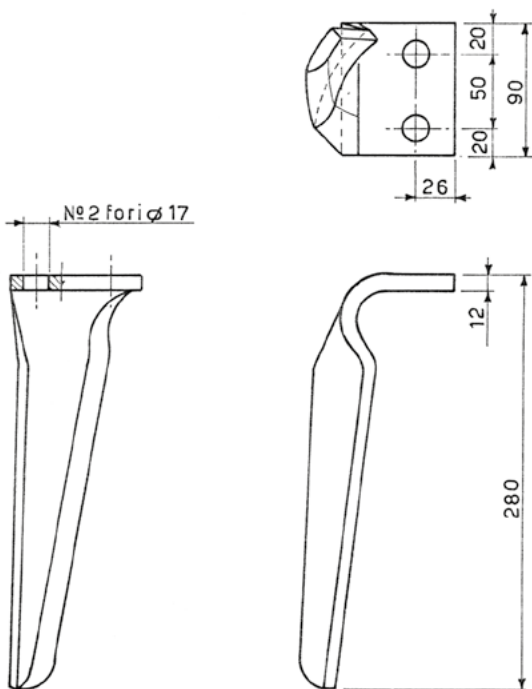

DENTI PER ERPICE ROTANTE

Tines for rotary harrows

Kreiseleggenzinken

Dents pour herses

Зубья ротационной бороны



Marca della macchina
Machine brand name
Marke der Maschine
Marque de la machine
Марка машины

Tipo e codice originale
Type and original code
Typ original hersteller
Type et code d'origine
Тип и оригинальный код

Codice Nr.
Ref. Nr.
Re. Nr.
Ref. Nr.
Код №

Marca della macchina
Machine brand name
Marke der Maschine
Marque de la machine
Марка машины

Tipo e codice originale
Type and original code
Typ original hersteller
Type et code d'origine
Тип и оригинальный код

Codice Nr.
Ref. Nr.
Re. Nr.
Ref. Nr.
Код №

RICAMBIO NON ORIGINALE PER

FALC

FOX 90x15

181053

511191 / 511192

gr 2210

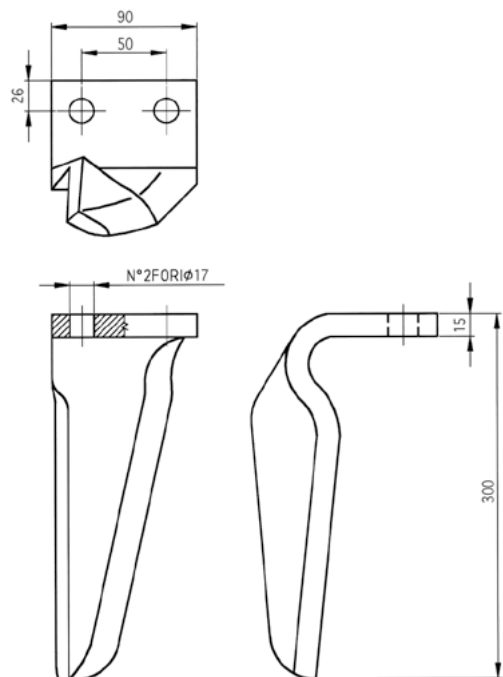

RICAMBIO NON ORIGINALE PER

FERABOLI

FN V.T. 100x12

417004

7A48010

gr 2000

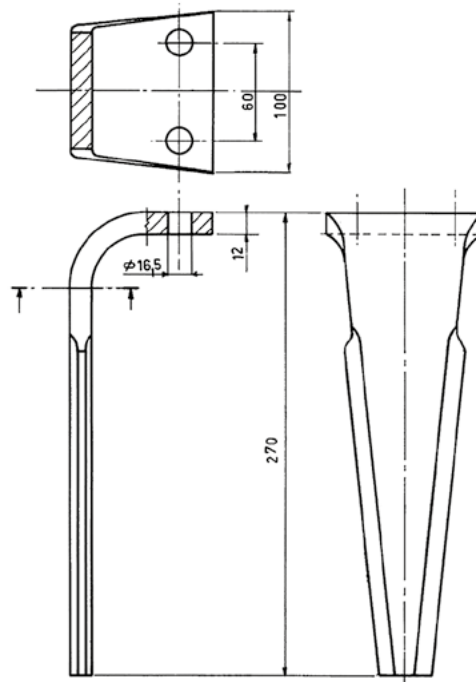

RICAMBIO NON ORIGINALE PER

FERABOLI

PUNTA A SALDARE

417005

gr 850

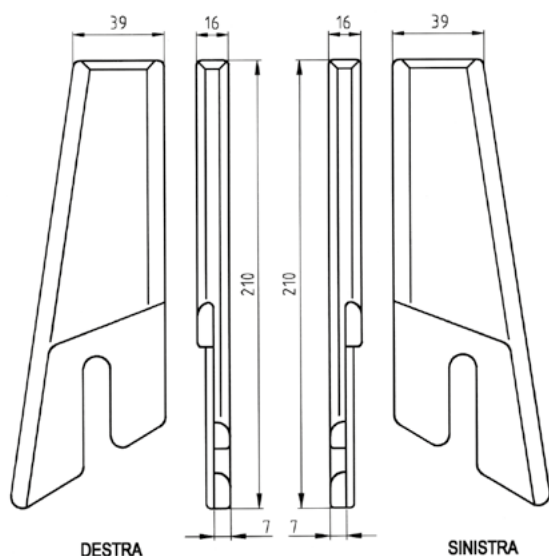

RICAMBIO NON ORIGINALE PER

FERABOLI

FS V.T. 112x15

417006

7A48011

gr 2640

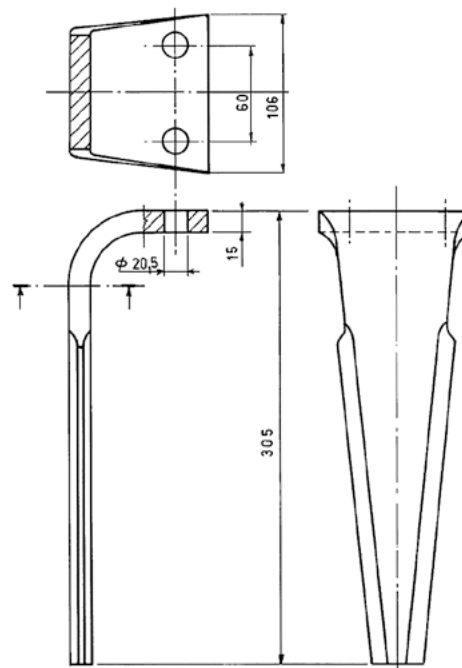

Tutti i modelli sono di nostra produzione e non originali.
All models are of our manufacture and are not original.
Alle unsere Landwirtschaftliche erzeugnisse sind unsere produktion und sind nicht original.
Tous les modèles sont notre production et ne sont pas des produits d'origine.
Все модели нашего производства и не являются оригинальными.

N.B. Pesi e misure sopra descritti sono puramente indicativi.
N.B. The above weights and dimensions are given for reference only.
N.B. Die obengenannten Gewichte und Abmessungen sind richtungsweisend.
N.B. Les poids et les dimensions indiqués ci-dessus sont donnés à titre indicatif.
N.B. Указанные вес и размеры, являются ориентировочными.

© La riproduzione
anche parziale
del presente catalogo
è vietata.

DENTI PER ERPICE ROTANTE
Tines for rotary harrows
Kreiseleggenzinken
Dents pour herses
Зубья ротационной бороны



Marca della macchina
 Machine brand name
 Marke der Maschine
 Marque de la machine
 Марка машины

Tipo e codice originale
 Type and original code
 Typ original hersteller
 Type et code d'origine
 Тип и оригинальный код

Codice Nr.
 Ref. Nr.
 Re. Nr.
 Ref. Nr.
 Код №

Marca della macchina
 Machine brand name
 Marke der Maschine
 Marque de la machine
 Марка машины

Tipo e codice originale
 Type and original code
 Typ original hersteller
 Type et code d'origine
 Тип и оригинальный код

Codice Nr.
 Ref. Nr.
 Re. Nr.
 Ref. Nr.
 Код №

RICAMBIO NON ORIGINALE PER FERABOLI	MASTER 100x12	417007	RICAMBIO NON ORIGINALE PER FERABOLI	TOP 110x15	417008
		gr 1850			

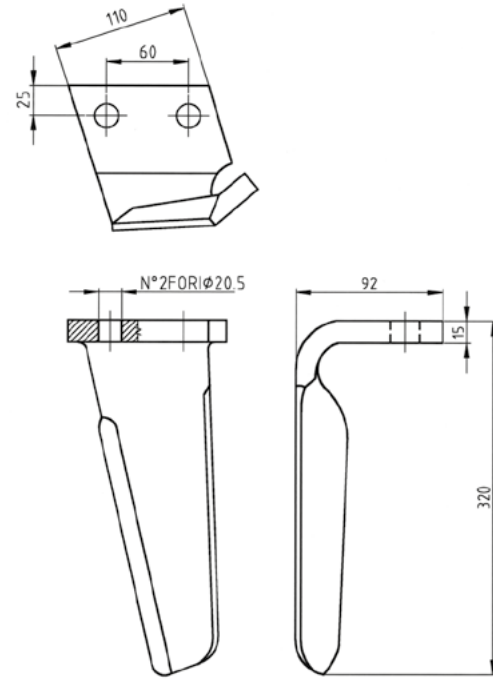
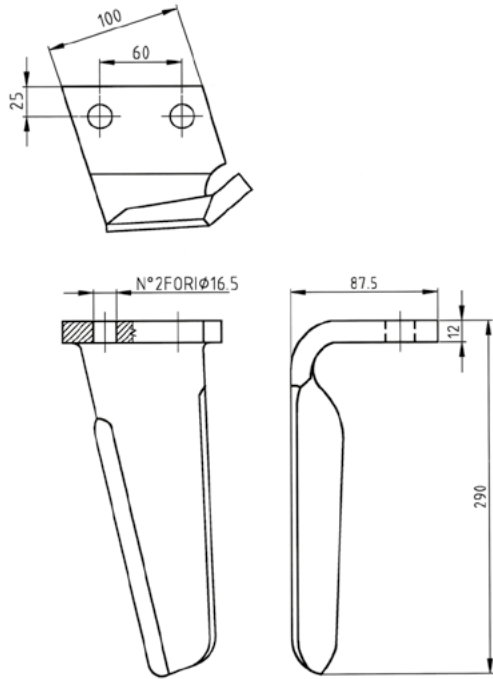

RICAMBIO NON ORIGINALE PER FORIGO-ROTTER ITALIA	E/41 CF	418003	RICAMBIO NON ORIGINALE PER FORIGO-ROTTER ITALIA	F60/90 ZEUS 80x12	418006
	RL013001	gr 1380			RLM71001

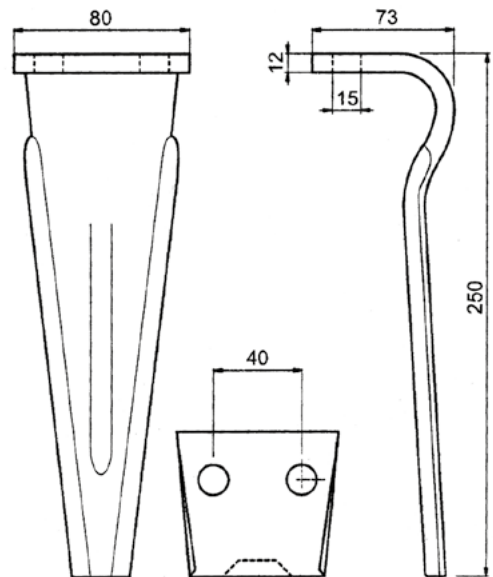
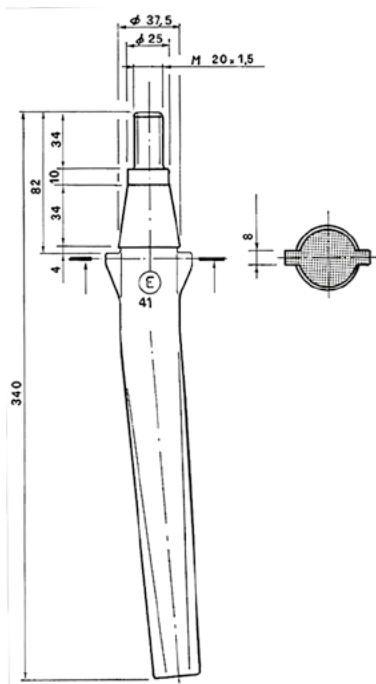

DENTI PER ERPICE ROTANTE
Tines for rotary harrows
Kreiseleggenzinken
Dents pour herses
Зубья ротационной бороны



Marca della macchina Machine brand name Marke der Maschine Marque de la machine Марка машины	Tipo e codice originale Type and original code Typ original hersteller Type et code d'origine Тип и оригинальный код	Codice Nr. Ref. Nr. Re. Nr. Ref. Nr. Код №	Marca della macchina Machine brand name Marke der Maschine Marque de la machine Марка машины	Tipo e codice originale Type and original code Typ original hersteller Type et code d'origine Тип и оригинальный код	Codice Nr. Ref. Nr. Re. Nr. Ref. Nr. Код №
--	--	--	--	--	--

RICAMBIO NON ORIGINALE PER FORIGO-ROTTER ITALIA	F120/180 105x15 RLM58001	418008 gr 2230	RICAMBIO NON ORIGINALE PER FORIGO-ROTTER ITALIA	F/100 95x12 1005801	418009 gr 1680
---	---	------------------------------	---	--	------------------------------

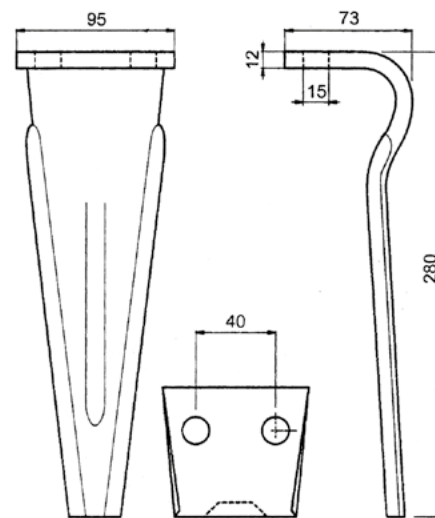
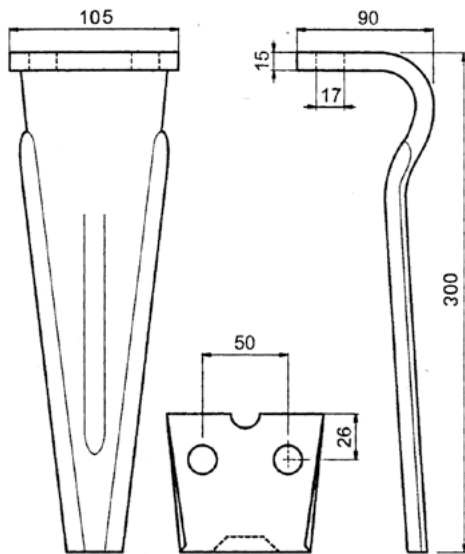

RICAMBIO NON ORIGINALE PER HOWARD-ROTAVATOR	100x15 - BATTUTO 185505 / 185506	225065 gr 2478	RICAMBIO NON ORIGINALE PER HOWARD-ROTAVATOR	100x12 182935 / 182936	423001 gr 1860
---	---	------------------------------	---	---	------------------------------

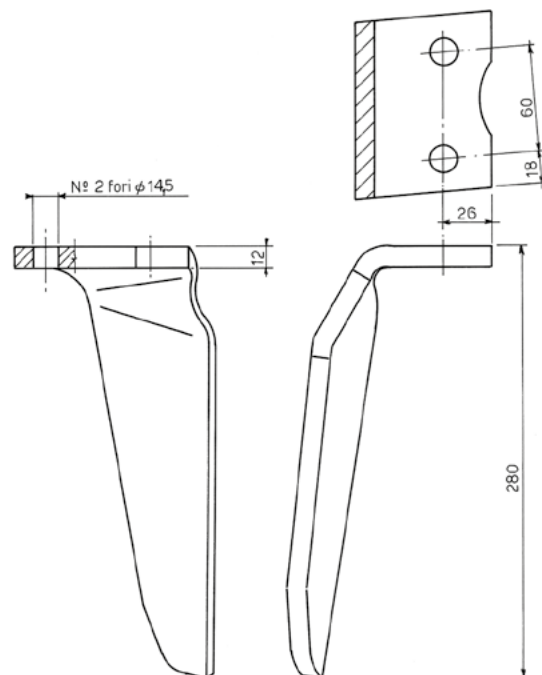
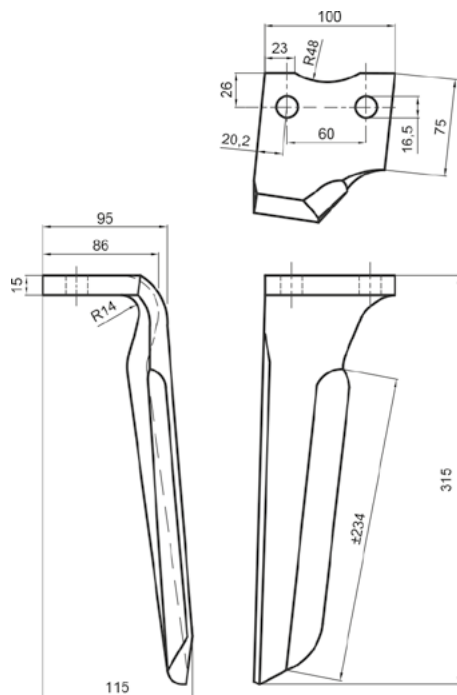

Tutti i modelli sono di nostra produzione e non originali.
 All models are of our manufacture and are not original.
 Alle unsere Landwirtschaftliche erzeugnisse sind unsere produktion und sind nicht original.
 Tous les modèles sont notre production et ne sont pas des produits d'origine.
 Все модели нашего производства и не являются оригинальными.

N.B. Pesi e misure sopra descritti sono puramente indicativi.
 N.B. The above weights and dimensions are given for reference only.
 N.B. Die obengenannten Gewichte und Abmessungen sind richtungsweisend.
 N.B. Les poids et les dimensions indiqués ci-dessus sont donnés à titre indicatif.
 N.B. Указанные вес и размеры, являются ориентировочными.

© La riproduzione anche parziale del presente catalogo è vietata.

DENTI PER ERPICE ROTANTE
Tines for rotary harrows
Kreiseleggenzinken
Dents pour herses
Зубья ротационной бороны



Marca della macchina
 Machine brand name
 Marke der Maschine
 Marque de la machine
 Марка машины

Tipo e codice originale
 Type and original code
 Typ original hersteller
 Type et code d'origine
 Тип и оригинальный код

Codice Nr.
 Ref. Nr.
 Re. Nr.
 Ref. Nr.
 Код №

Marca della macchina
 Machine brand name
 Marke der Maschine
 Marque de la machine
 Марка машины

Tipo e codice originale
 Type and original code
 Typ original hersteller
 Type et code d'origine
 Тип и оригинальный код

Codice Nr.
 Ref. Nr.
 Re. Nr.
 Ref. Nr.
 Код №

RICAMBIO NON ORIGINALE PER HOWARD-ROTAVATOR	DENTE 100x15	225044	RICAMBIO NON ORIGINALE PER HOWARD-ROTAVATOR	100x15	225047
	NON BATTUTO	gr 2500		182939 / 182940	gr 2409

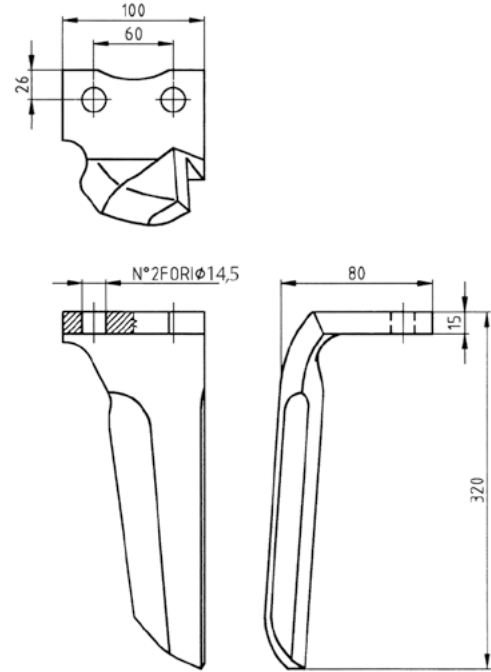
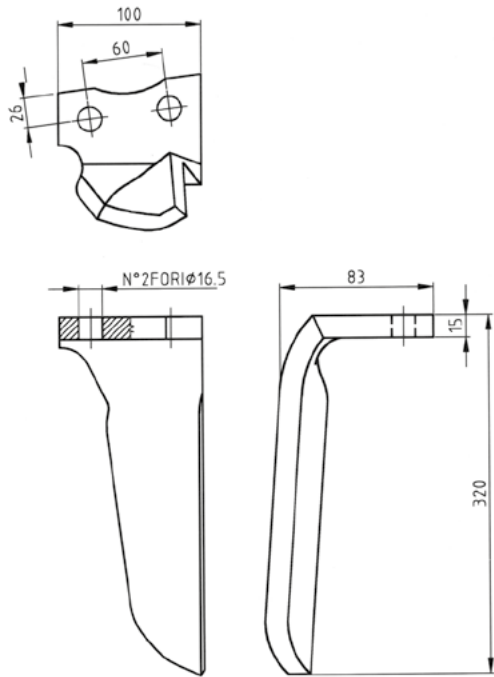

RICAMBIO NON ORIGINALE PER KUHN	DENTE 110x16	237021	RICAMBIO NON ORIGINALE PER KUHN	DENTE 110x12	237024
	525604 / 525605	gr 2800		525494 / 525495	gr 2000

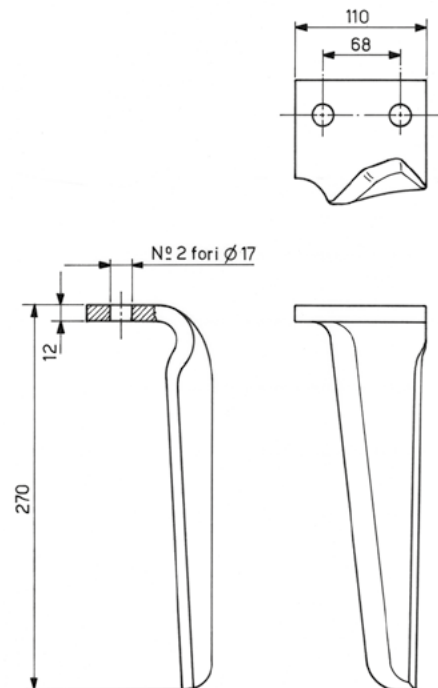
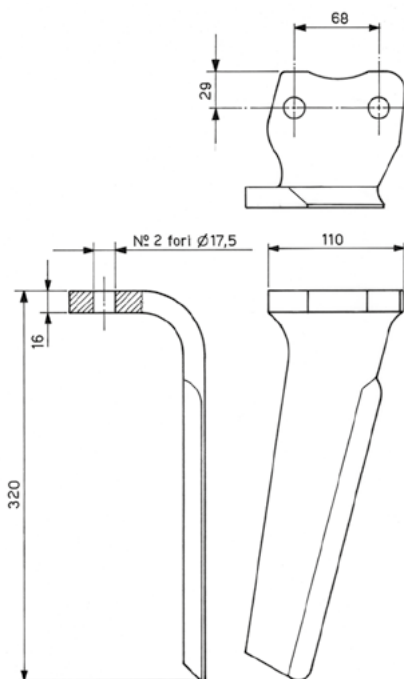

DENTI PER ERPICE ROTANTE
Tines for rotary harrows
Kreiseleggenzinken
Dents pour herses
Зубья ротационной бороны



Marca della macchina Machine brand name Marke der Maschine Marque de la machine Марка машины	Tipo e codice originale Type and original code Typ original hersteller Type et code d'origine Тип и оригинальный код	Codice Nr. Ref. Nr. Re. Nr. Ref. Nr. Код №	Marca della macchina Machine brand name Marke der Maschine Marque de la machine Марка машины	Tipo e codice originale Type and original code Typ original hersteller Type et code d'origine Тип и оригинальный код	Codice Nr. Ref. Nr. Re. Nr. Ref. Nr. Код №
--	--	--	--	--	--

RICAMBIO NON ORIGINALE PER KUHN	FORGED TYPE 110x16 STAMPATO	237027	RICAMBIO NON ORIGINALE PER KUHN	FERMA VITE INT.68	237030
	52539400A / 52539500A	gr 2850			gr 190

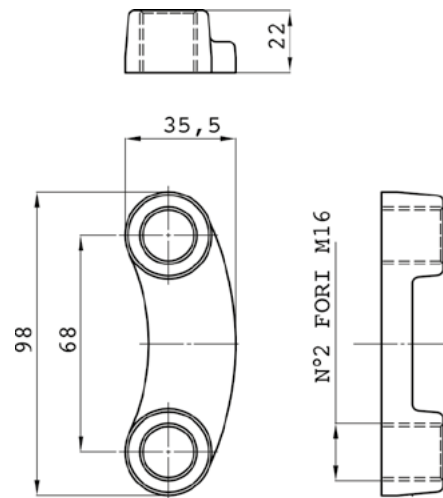
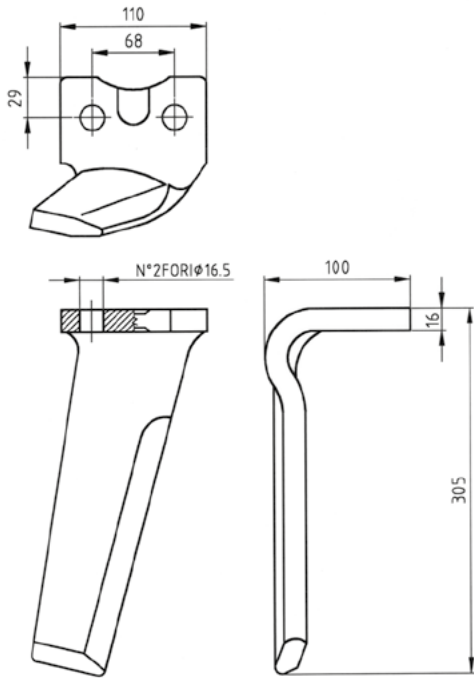

RICAMBIO NON ORIGINALE PER KUHN	ATTACCO RAPIDO STAMPATO	237036	RICAMBIO NON ORIGINALE PER KUHN	ATTACCO RAPIDO 120x16	237041
	52596410 / 52596510	gr 3200			K2500090 / 100

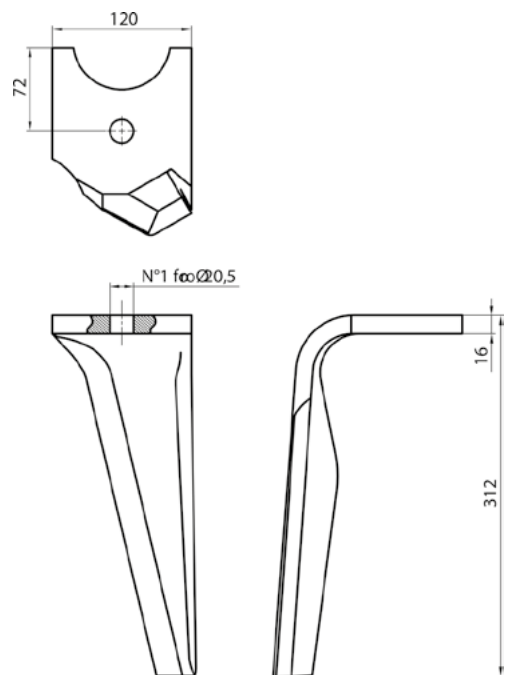
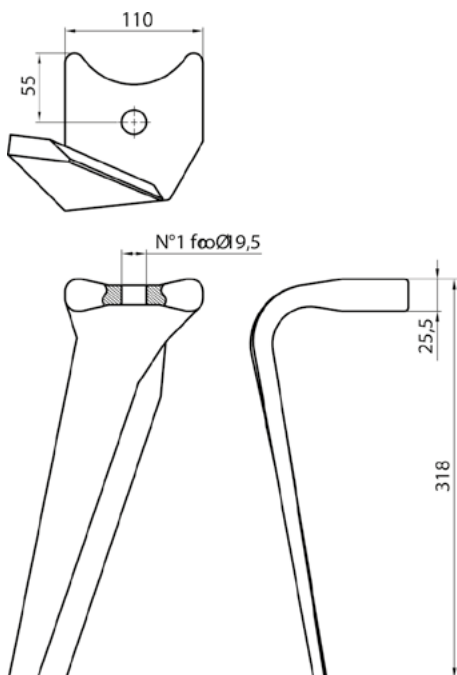

Tutti i modelli sono di nostra produzione e non originali.
 All models are of our manufacture and are not original.
 Alle unsere Landwirtschaftliche erzeugnisse sind unsere produktion und sind nicht original.
 Tous les modèles sont notre production et ne sont pas des produits d'origine.
 Все модели нашего производства и не являются оригинальными.

N.B. Pesi e misure sopra descritti sono puramente indicativi.
 N.B. The above weights and dimensions are given for reference only.
 N.B. Die obengenannten Gewichte und Abmessungen sind richtungsweisend.
 N.B. Les poids et les dimensions indiqués ci-dessus sont donnés à titre indicatif.
 N.B. Указанные вес и размеры, являются ориентировочными.

© La riproduzione
 anche parziale
 del presente catalogo
 è vietata.

DENTI PER ERPICE ROTANTE
Tines for rotary harrows
Kreiseleggenzinken
Dents pour herses
Зубья ротационной бороны



Marca della macchina
 Machine brand name
 Marke der Maschine
 Marque de la machine
 Марка машины

Tipo e codice originale
 Type and original code
 Typ original hersteller
 Type et code d'origine
 Тип и оригинальный код

Codice Nr.
 Ref. Nr.
 Re. Nr.
 Ref. Nr.
 Код №

Marca della macchina
 Machine brand name
 Marke der Maschine
 Marque de la machine
 Марка машины

Tipo e codice originale
 Type and original code
 Typ original hersteller
 Type et code d'origine
 Тип и оригинальный код

Codice Nr.
 Ref. Nr.
 Re. Nr.
 Ref. Nr.
 Код №

RICAMBIO NON ORIGINALE PER KUHN	DENTE STAMPATO	237045	RICAMBIO NON ORIGINALE PER KUHN	DENTE STAMPATO	237046
	52539400A / 52539500A	gr 4200		52625500 / 52625400	gr 3600

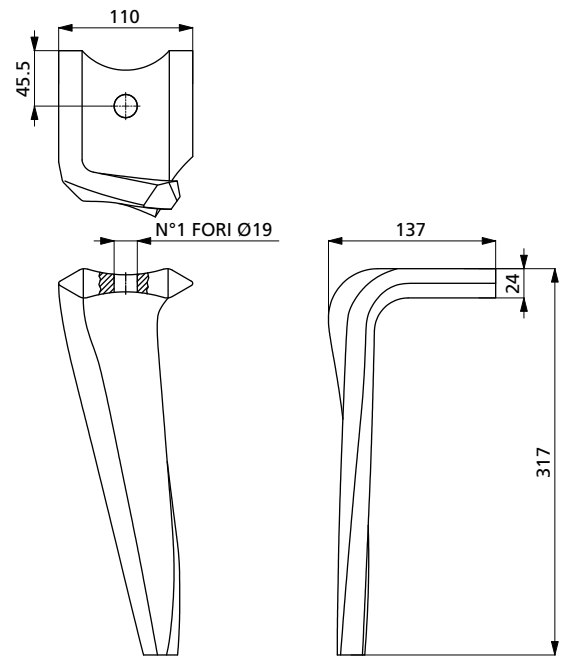
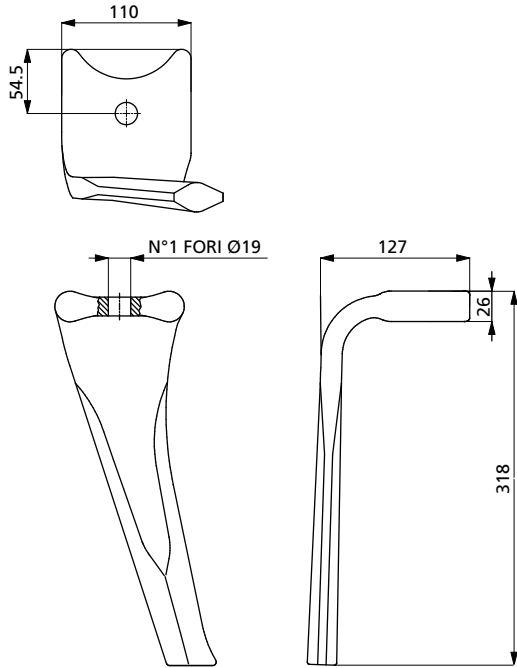

RICAMBIO NON ORIGINALE PER KUHN	DENTE CULTIVILLER STAMPATO	237047	RICAMBIO NON ORIGINALE PER KUHN	DENTE 110x14	237050
	52359500	gr 3200		525524 / 525525	gr 2640

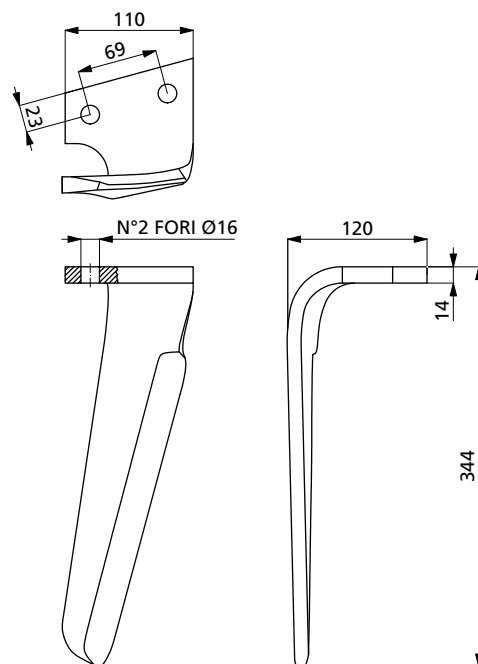
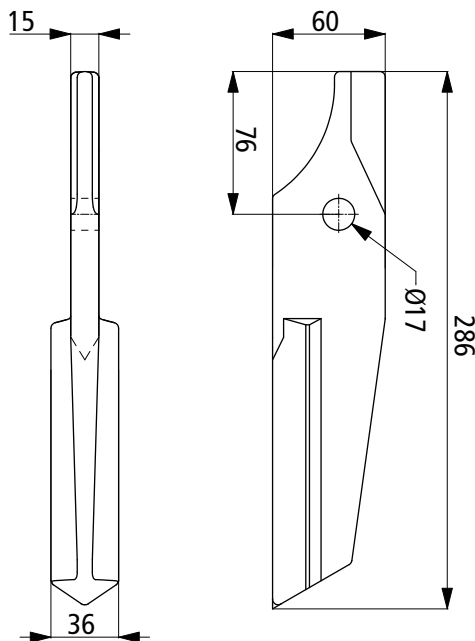

DENTI PER ERPICE ROTANTE
Tines for rotary harrows
Kreiseleggenzinken
Dents pour herses
Зубья ротационной бороны



Marca della macchina Machine brand name Marke der Maschine Marque de la machine Марка машины	Tipo e codice originale Type and original code Typ original hersteller Type et code d'origine Тип и оригинальный код	Codice Nr. Ref. Nr. Re. Nr. Ref. Nr. Код №	Marca della macchina Machine brand name Marke der Maschine Marque de la machine Марка машины	Tipo e codice originale Type and original code Typ original hersteller Type et code d'origine Тип и оригинальный код	Codice Nr. Ref. Nr. Re. Nr. Ref. Nr. Код №
--	--	--	--	--	--

RICAMBIO NON ORIGINALE PER KUHN	ATTACCO RAPIDO 110x14 237051	RICAMBIO NON ORIGINALE PER KUHN	E/15 CORTO 40x18 427001
	K2500071 / K2500081 gr 2800		525037 / 525038 gr 1340

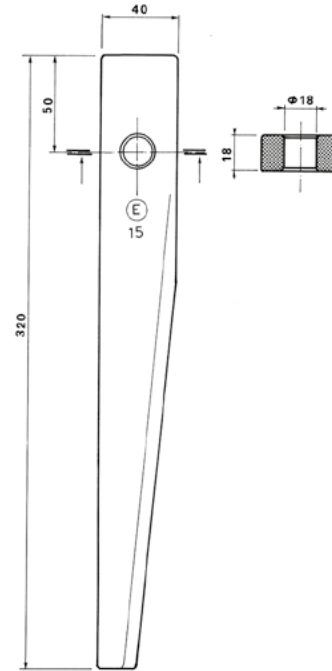
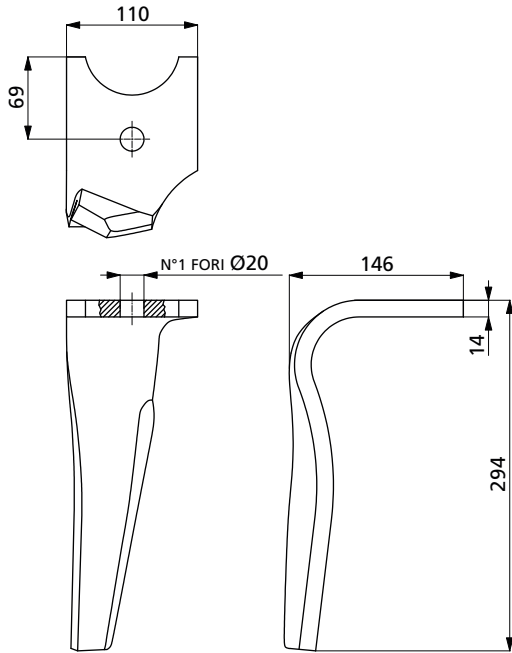

RICAMBIO NON ORIGINALE PER KUHN	E/L 15 LUNGO 40x18 427002	RICAMBIO NON ORIGINALE PER KVERNELAND	90x12 252051
	525106 gr 1700		E010146 / E020146 gr 1730

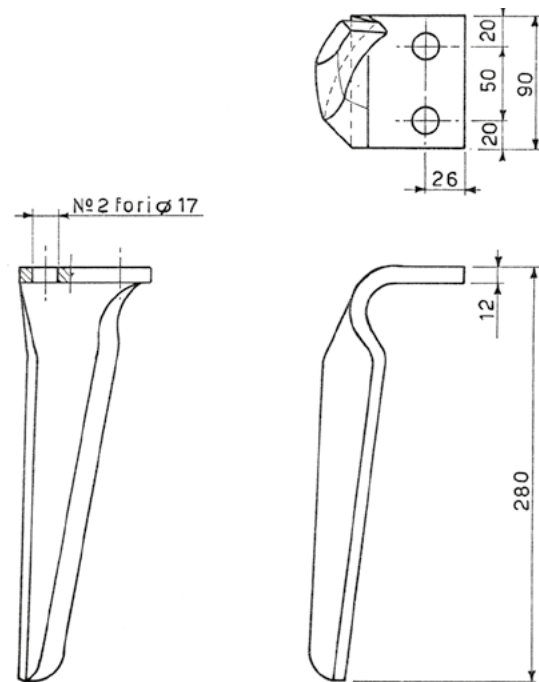
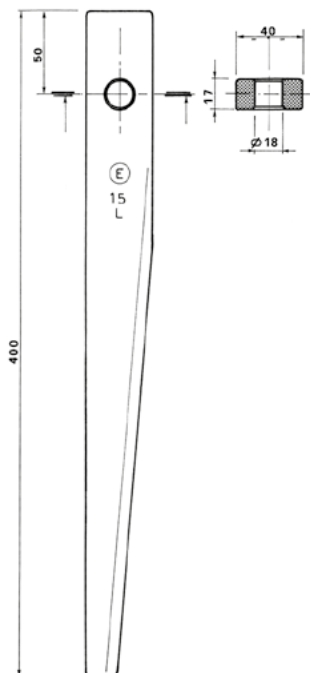

Tutti i modelli sono di nostra produzione e non originali.
 All models are of our manufacture and are not original.
 Alle unsere Landwirtschaftliche erzeuignisse sind unsere produktion und sind nicht original.
 Tous les modèles sont notre production et ne sont pas des produits d'origine.
 Все модели нашего производства и не являются оригинальными.

N.B. Pesi e misure sopra descritti sono puramente indicativi.
 N.B. The above weights and dimensions are given for reference only.
 N.B. Die obengenannten Gewichte und Abmessungen sind richtungsweisend.
 N.B. Les poids et les dimensions indiqués ci-dessus sont donnés à titre indicatif.
 N.B. Указанные вес и размеры, являются ориентировочными.

© La riproduzione
 anche parziale
 del presente catalogo
 è vietata.

DENTI PER ERPICE ROTANTE
Tines for rotary harrows
Kreiseleggenzinken
Dents pour herses
Зубья ротационной бороны



Marca della macchina
 Machine brand name
 Marke der Maschine
 Marque de la machine
 Марка машины

Tipo e codice originale
 Type and original code
 Typ original hersteller
 Type et code d'origine
 Тип и оригинальный код

Codice Nr.
 Ref. Nr.
 Re. Nr.
 Ref. Nr.
 Код №

Marca della macchina
 Machine brand name
 Marke der Maschine
 Marque de la machine
 Марка машины

Tipo e codice originale
 Type and original code
 Typ original hersteller
 Type et code d'origine
 Тип и оригинальный код

Codice Nr.
 Ref. Nr.
 Re. Nr.
 Ref. Nr.
 Код №

RICAMBIO NON ORIGINALE PER KVERNELAND	110x15	252054	RICAMBIO NON ORIGINALE PER KVERNELAND	110x18	252088
	E030146 / E040146	gr 2940		E080246 / E070246	gr 3050

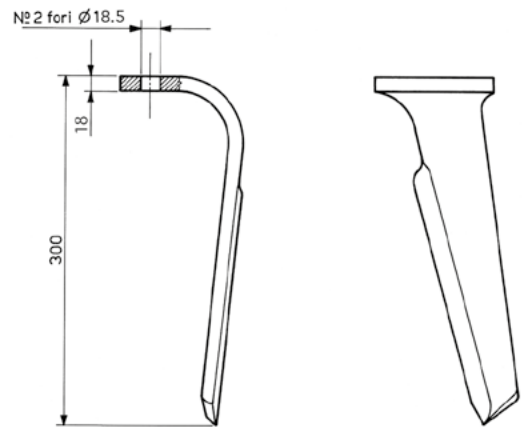
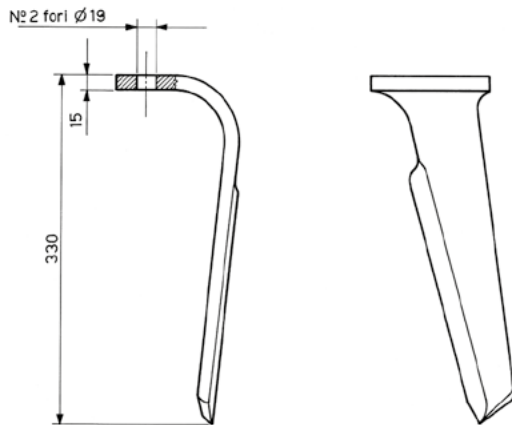
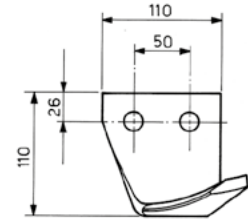
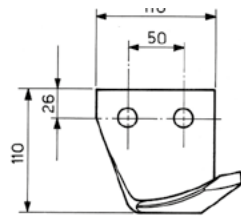

RICAMBIO NON ORIGINALE PER KVERNELAND	ATTACCO RAPIDO 100x15	252095	RICAMBIO NON ORIGINALE PER KVERNELAND	ATTACCO RAPIDO 100x18	252098
	46000150 / 46000151	gr 3400		44000150 / 44000151	gr 3800

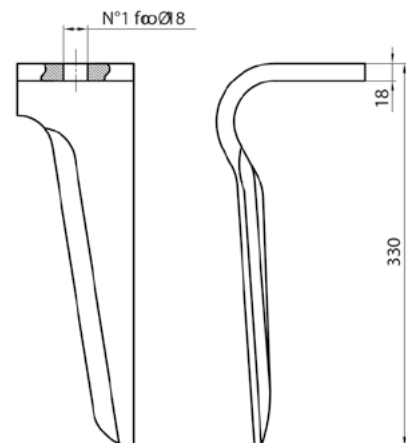
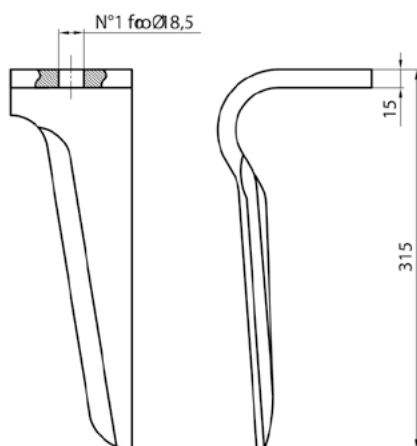
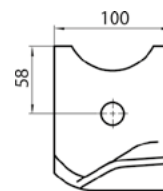
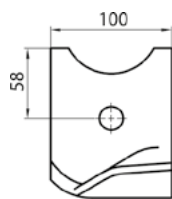

DENTI PER ERPICE ROTANTE
Tines for rotary harrows
Kreiseleggenzinken
Dents pour herses
Зубья ротационной бороны



Marca della macchina Machine brand name Marke der Maschine Marque de la machine Марка машины	Tipo e codice originale Type and original code Typ original hersteller Type et code d'origine Тип и оригинальный код	Codice Nr. Ref. Nr. Re. Nr. Ref. Nr. Код №	Marca della macchina Machine brand name Marke der Maschine Marque de la machine Марка машины	Tipo e codice originale Type and original code Typ original hersteller Type et code d'origine Тип и оригинальный код	Codice Nr. Ref. Nr. Re. Nr. Ref. Nr. Код №
--	--	--	--	--	--

RICAMBIO NON ORIGINALE PER LELY	E/1A CONICO	435001	RICAMBIO NON ORIGINALE PER LELY	E/4A CILINDRICO	435002
	1169902200	gr 1330		11606021	gr 1040

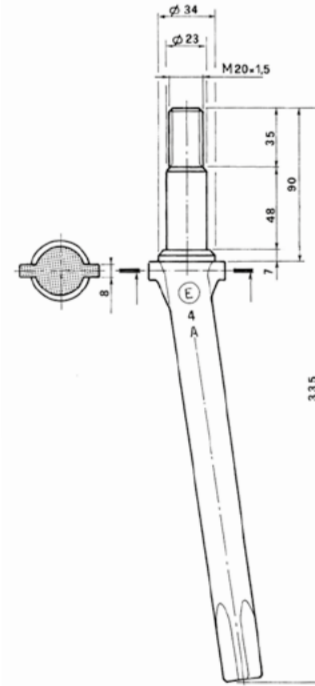
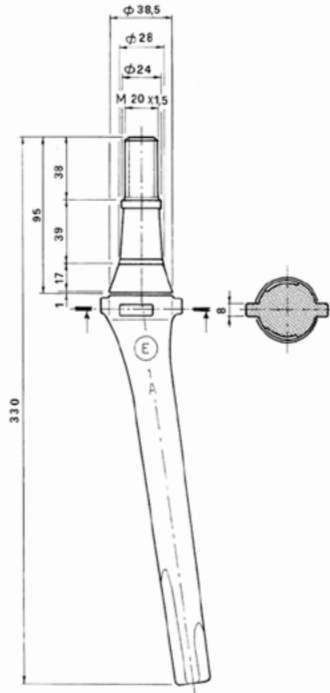

RICAMBIO NON ORIGINALE PER LELY	E/1B CONICO LUNGO	435004	RICAMBIO NON ORIGINALE PER LELY	CONICO A COLTELLO DX/SX	435007
	116321487.0	gr 1565		116322240 / 116322241	gr 1710

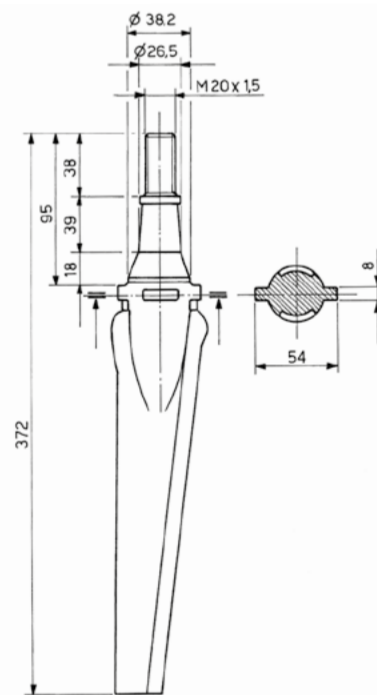
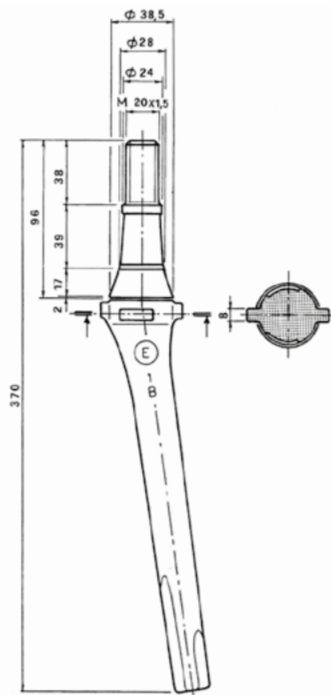

Tutti i modelli sono di nostra produzione e non originali.
 All models are of our manufacture and are not original.
 Alle unsere Landwirtschaftliche erzeugnisse sind unsere produktion und sind nicht original.
 Tous les modèles sont notre production et ne sont pas des produits d'origine.
 Все модели нашего производства и не являются оригинальными.

N.B. Pesi e misure sopra descritti sono puramente indicativi.
 N.B. The above weights and dimensions are given for reference only.
 N.B. Die obengenannten Gewichte und Abmessungen sind richtungsweisend.
 N.B. Les poids et les dimensions indiqués ci-dessus sont donnés à titre indicatif.
 N.B. Указанные вес и размеры, являются ориентировочными.

© La riproduzione anche parziale del presente catalogo è vietata.

DENTI PER ERPICE ROTANTE
Tines for rotary harrows
Kreiseleggenzinken
Dents pour herses
Зубья ротационной бороны



Marca della macchina
 Machine brand name
 Marke der Maschine
 Marque de la machine
 Марка машины

Tipo e codice originale
 Type and original code
 Typ original hersteller
 Type et code d'origine
 Тип и оригинальный код

Codice Nr.
 Ref. Nr.
 Re. Nr.
 Ref. Nr.
 Код №

Marca della macchina
 Machine brand name
 Marke der Maschine
 Marque de la machine
 Марка машины

Tipo e codice originale
 Type and original code
 Typ original hersteller
 Type et code d'origine
 Тип и оригинальный код

Codice Nr.
 Ref. Nr.
 Re. Nr.
 Ref. Nr.
 Код №

RICAMBIO NON ORIGINALE PER LELY	PUNTA A SALDARE	435009	RICAMBIO NON ORIGINALE PER LELY	CLUB - GOCCIA	435010
		gr 400			116990111 / 116990112

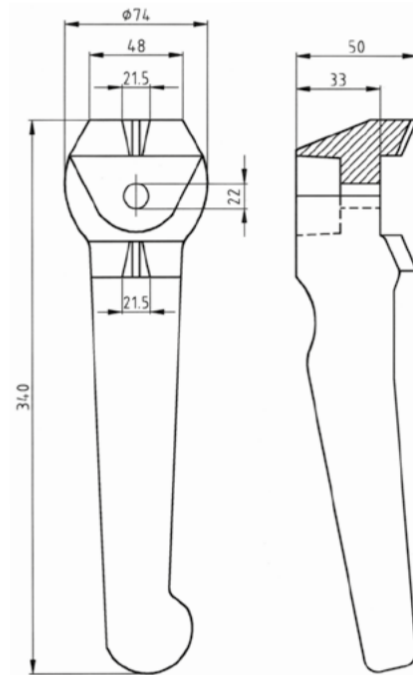
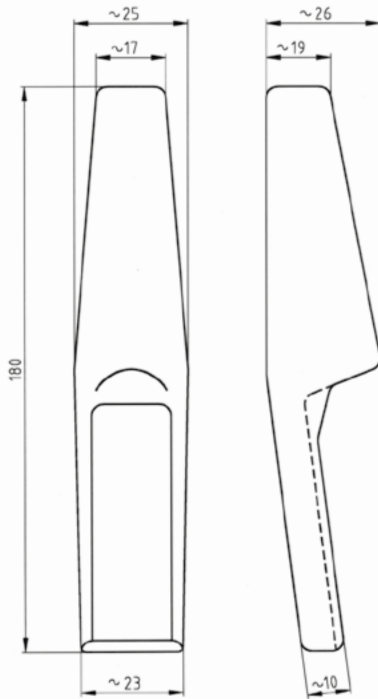

RICAMBIO NON ORIGINALE PER LELY	CONICO LUNGO GOCCIA	435012	RICAMBIO NON ORIGINALE PER LELY	STANDART GOCCIA CORTO	435013
		gr 1630			

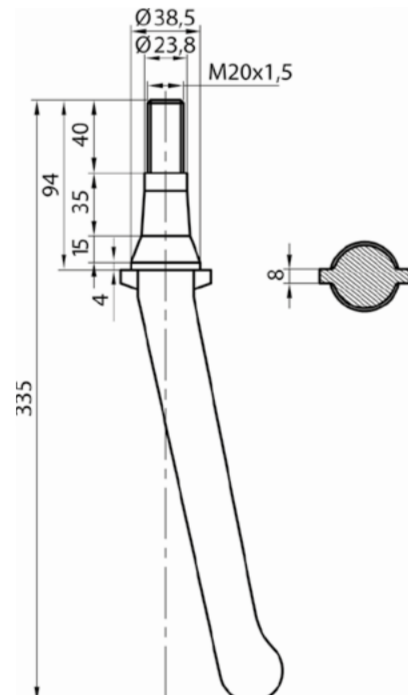
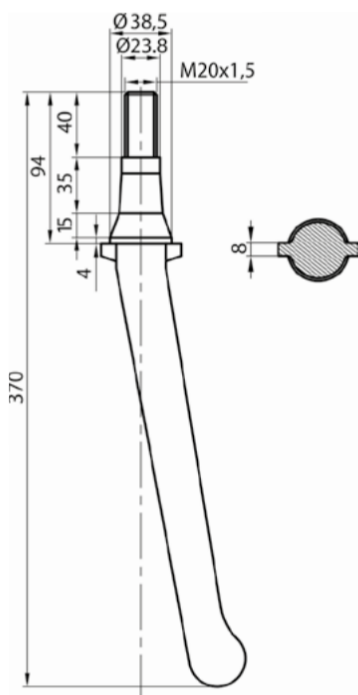

DENTI PER ERPICE ROTANTE
Tines for rotary harrows
Kreiseleggenzinken
Dents pour herses
Зубья ротационной бороны



Marca della macchina Machine brand name Marke der Maschine Marque de la machine Марка машины	Tipo e codice originale Type and original code Typ original hersteller Type et code d'origine Тип и оригинальный код	Codice Nr. Ref. Nr. Re. Nr. Ref. Nr. Код №	Marca della macchina Machine brand name Marke der Maschine Marque de la machine Марка машины	Tipo e codice originale Type and original code Typ original hersteller Type et code d'origine Тип и оригинальный код	Codice Nr. Ref. Nr. Re. Nr. Ref. Nr. Код №
--	--	--	--	--	--

RICAMBIO NON ORIGINALE PER LEMKEN	DENTE 110x15	436002	RICAMBIO NON ORIGINALE PER MASCHIO	ROTOTERRA-HB-DX/SX 60x10	255021
	3377022 / 3377023	gr 2960		10100262 / 10100263	gr 1290

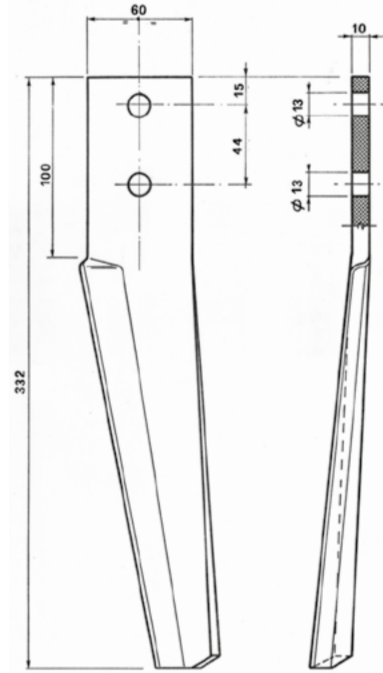
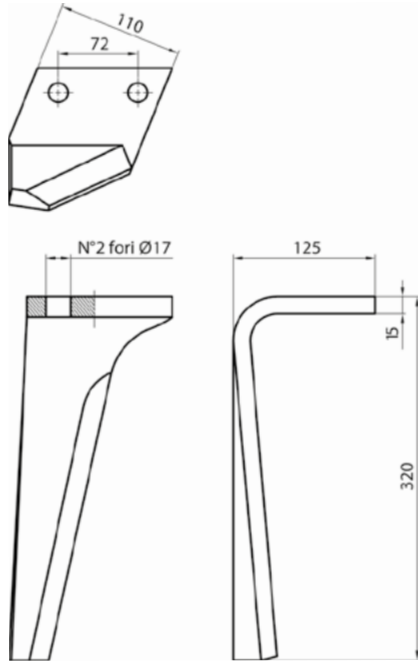

RICAMBIO NON ORIGINALE PER MASCHIO	ROTOTERRA-HB-DX/SX 60x12	255022	RICAMBIO NON ORIGINALE PER MASCHIO	PROTEZIONE HB 75x6	255034
	10100225 / 10100226	gr 1510		10100247	gr 330

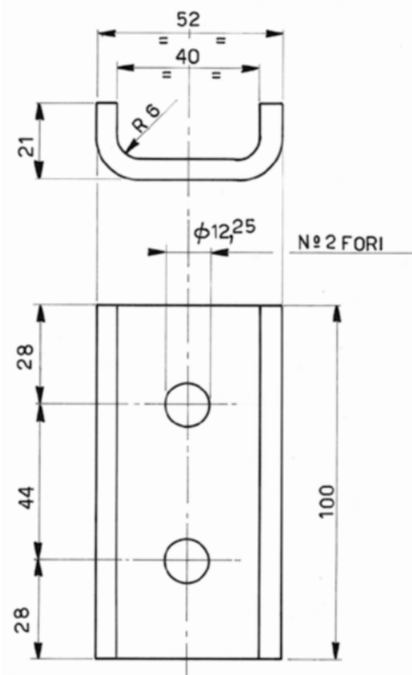
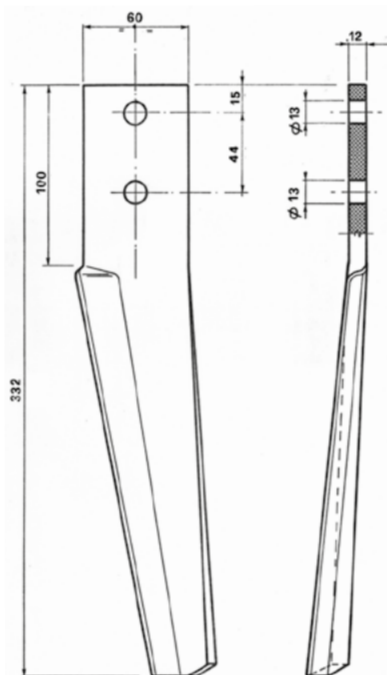

Tutti i modelli sono di nostra produzione e non originali.
 All models are of our manufacture and are not original.
 Alle unsere Landwirtschaftliche erzeugnisse sind unsere produktion und sind nicht original.
 Tous les modèles sont notre production et ne sont pas des produits d'origine.
 Все модели нашего производства и не являются оригинальными.

N.B. Pesi e misure sopra descritti sono puramente indicativi.
 N.B. The above weights and dimensions are given for reference only.
 N.B. Die obengenannten Gewichte und Abmessungen sind richtungsweisend.
 N.B. Les poids et les dimensions indiqués ci-dessus sont donnés à titre indicatif.
 N.B. Указанные вес и размеры, являются ориентировочными.

© La riproduzione
 anche parziale
 del presente catalogo
 è vietata.

DENTI PER ERPICE ROTANTE
Tines for rotary harrows
Kreiseleggenzinken
Dents pour herses
Зубья ротационной бороны



Marca della macchina
 Machine brand name
 Marke der Maschine
 Marque de la machine
 Марка машины

Tipo e codice originale
 Type and original code
 Typ original hersteller
 Type et code d'origine
 Тип и оригинальный код

Codice Nr.
 Ref. Nr.
 Re. Nr.
 Ref. Nr.
 Код №

Marca della macchina
 Machine brand name
 Marke der Maschine
 Marque de la machine
 Марка машины

Tipo e codice originale
 Type and original code
 Typ original hersteller
 Type et code d'origine
 Тип и оригинальный код

Codice Nr.
 Ref. Nr.
 Re. Nr.
 Ref. Nr.
 Код №

RICAMBIO NON ORIGINALE PER MASCHIO	PROTEZIONE DC/DS/DL 100x6	255038	RICAMBIO NON ORIGINALE PER MASCHIO	DM AQUILA 100x12	255040
	38100215	gr 440		36100210 / 36100211	gr 1970

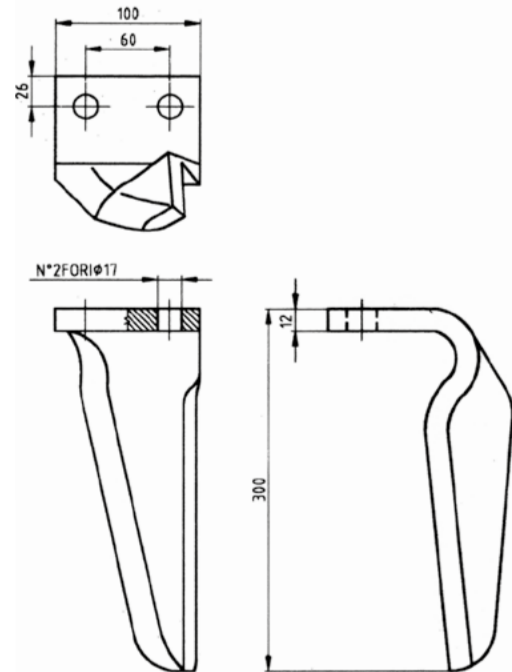
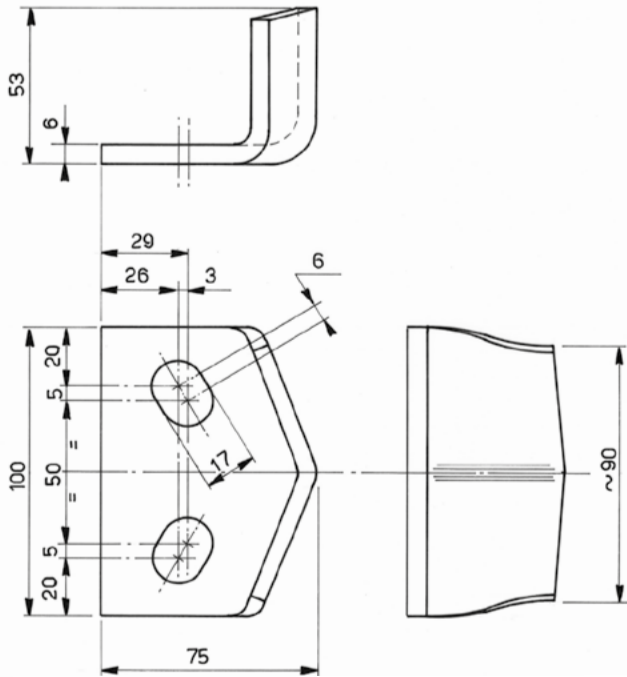

RICAMBIO NON ORIGINALE PER MASCHIO	DIAMANTE GABBIANO FALCO - DC/DS/DL 90x12	255041	RICAMBIO NON ORIGINALE PER MASCHIO	DM PESANTE 100x15	255058
	27100209 / 27100210	gr 1730		36100215 / 36100216	gr 2500

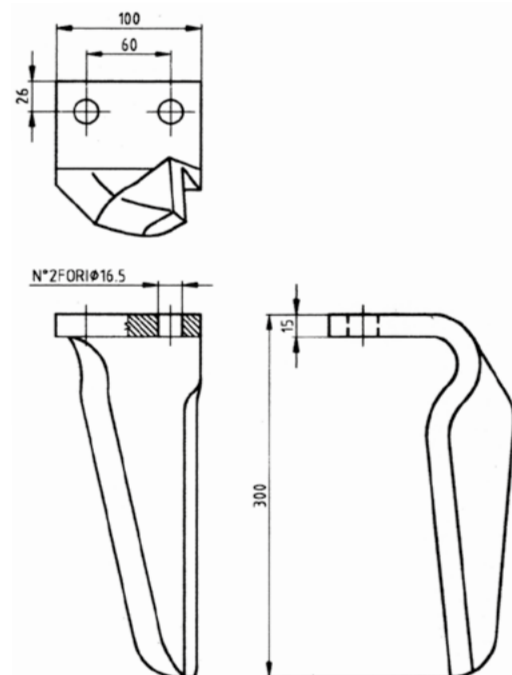
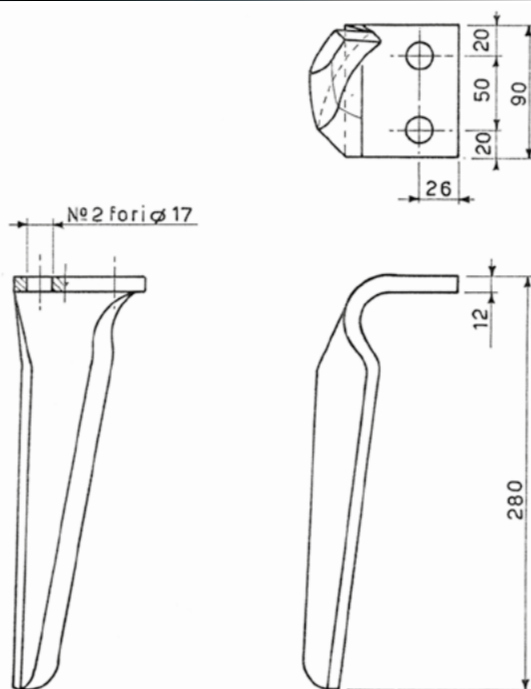

DENTI PER ERPICE ROTANTE
Tines for rotary harrows
Kreiseleggenzinken
Dents pour herses
Зубья ротационной бороны



Marca della macchina Machine brand name Marke der Maschine Marque de la machine Марка машины	Tipo e codice originale Type and original code Typ original hersteller Type et code d'origine Тип и оригинальный код	Codice Nr. Ref. Nr. Re. Nr. Ref. Nr. Код №	Marca della macchina Machine brand name Marke der Maschine Marque de la machine Марка машины	Tipo e codice originale Type and original code Typ original hersteller Type et code d'origine Тип и оригинальный код	Codice Nr. Ref. Nr. Re. Nr. Ref. Nr. Код №
--	--	--	--	--	--

MASCHIO RICAMBIO NON ORIGINALE PER	DC NT PESANTE 90x14	255059	MASCHIO RICAMBIO NON ORIGINALE PER	FERMO VITE DM	255048
	38100222 / 38100223	gr 2100		36100312	gr 190

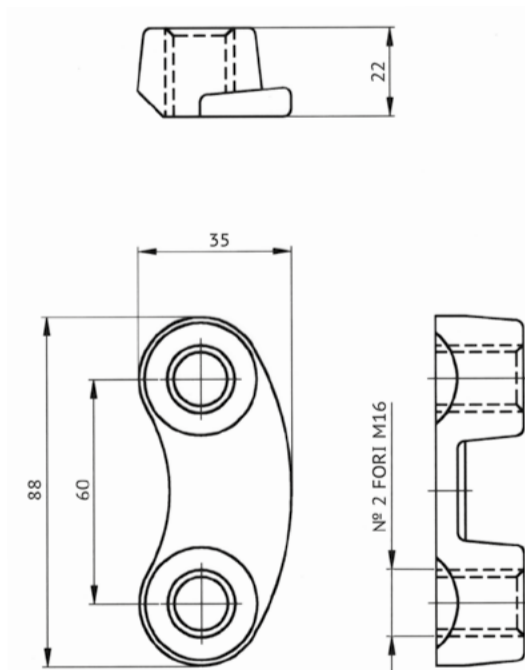
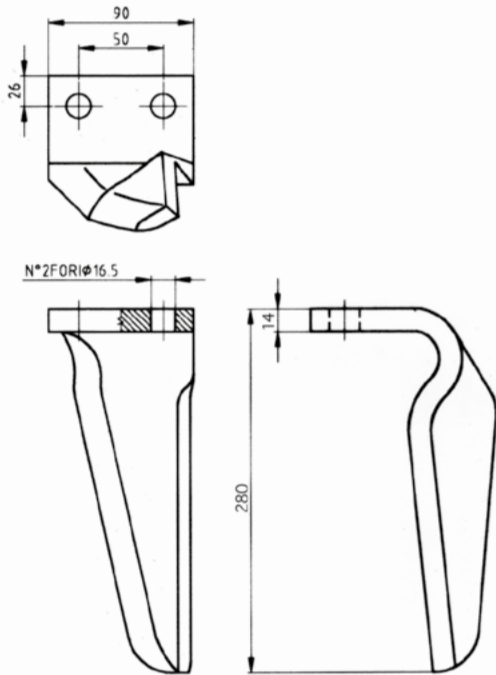

MASCHIO RICAMBIO NON ORIGINALE PER	FERMO VITE DC/DS/DL	255049	MASCHIO RICAMBIO NON ORIGINALE PER	DENTE 90x14	255059M1
	38100218	gr 180			gr 2200

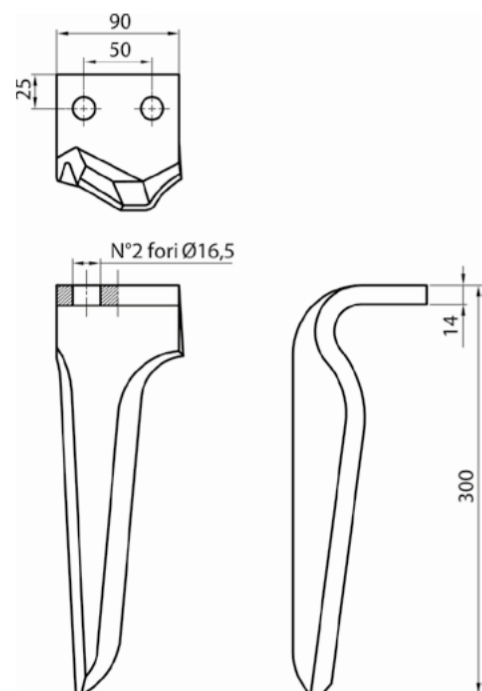
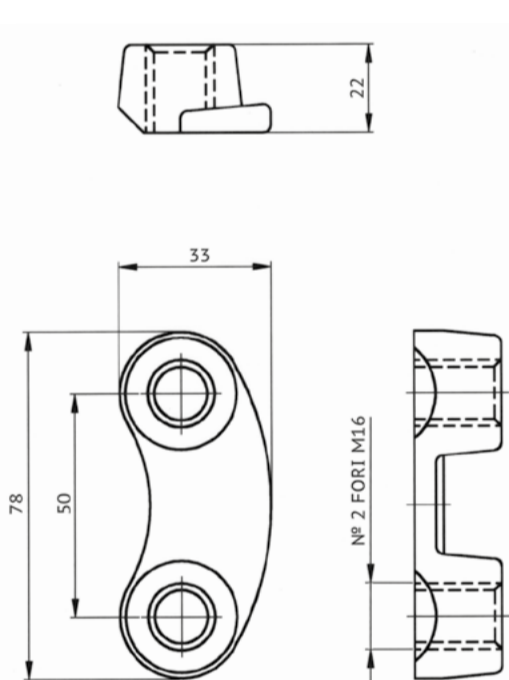

Tutti i modelli sono di nostra produzione e non originali.
 All models are of our manufacture and are not original.
 Alle unsere Landwirtschaftliche erzeugnisse sind unsere produktion und sind nicht original.
 Tous les modèles sont notre production et ne sont pas des produits d'origine.
 Все модели нашего производства и не являются оригинальными.

N.B. Pesi e misure sopra descritti sono puramente indicativi.
 N.B. The above weights and dimensions are given for reference only.
 N.B. Die obengenannten Gewichte und Abmessungen sind richtungsweisend.
 N.B. Les poids et les dimensions indiqués ci-dessus sont donnés à titre indicatif.
 N.B. Указанные вес и размеры, являются ориентировочными.

© La riproduzione
 anche parziale
 del presente catalogo
 è vietata.

DENTI PER ERPICE ROTANTE
Tines for rotary harrows
Kreiseleggenzinken
Dents pour herses
Зубья ротационной бороны



Marca della macchina
 Machine brand name
 Marke der Maschine
 Marque de la machine
 Марка машины

Tipo e codice originale
 Type and original code
 Typ original hersteller
 Type et code d'origine
 Тип и оригинальный код

Codice Nr.
 Ref. Nr.
 Re. Nr.
 Ref. Nr.
 Код №

Marca della macchina
 Machine brand name
 Marke der Maschine
 Marque de la machine
 Марка машины

Tipo e codice originale
 Type and original code
 Typ original hersteller
 Type et code d'origine
 Тип и оригинальный код

Codice Nr.
 Ref. Nr.
 Re. Nr.
 Ref. Nr.
 Код №

RICAMBIO NON ORIGINALE PER MASCHIO	DENTE CONDOR QUADRO 25	439003	RICAMBIO NON ORIGINALE PER MASCHIO	MEGA 110x15	255075
	M28100474	gr 890		M61100229 / M61100230	gr 2800

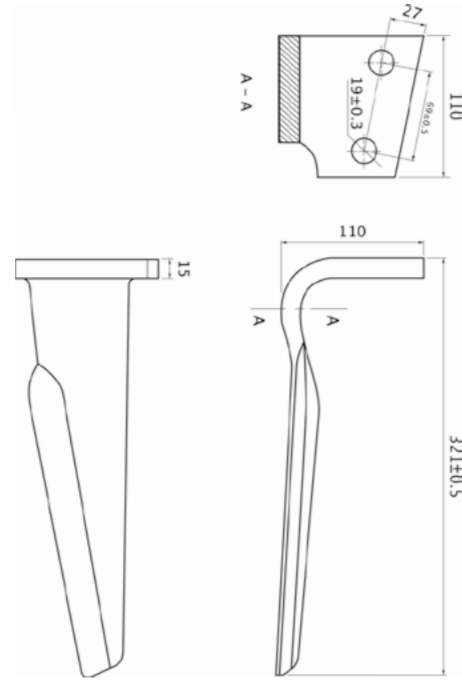
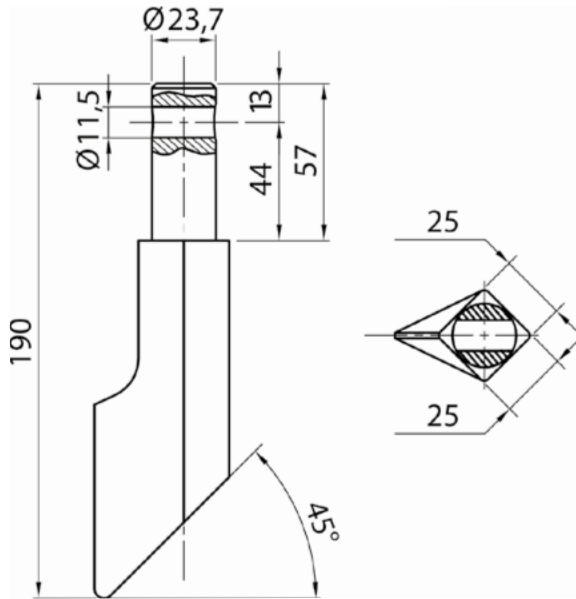

RICAMBIO NON ORIGINALE PER MORENI	100x12	267002	RICAMBIO NON ORIGINALE PER MORENI	E/7B CONICO	440002
	8000106 / 8000804	gr 2020			gr 1000

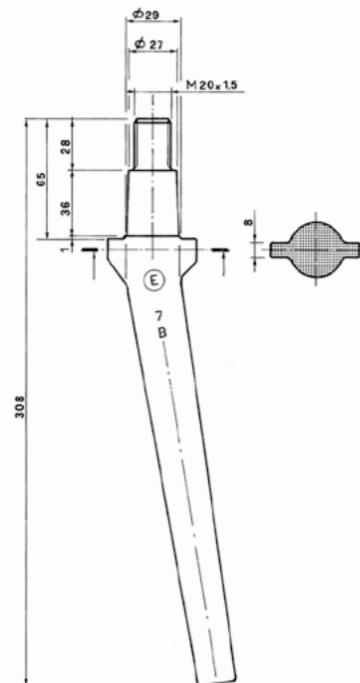
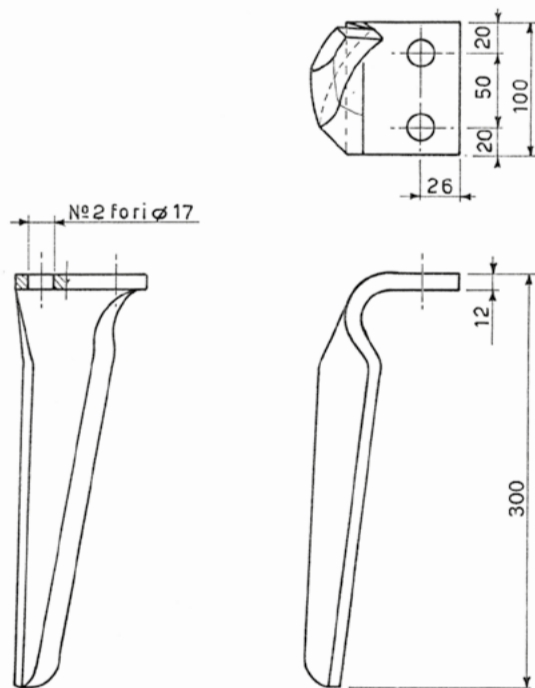

DENTI PER ERPICE ROTANTE
Tines for rotary harrows
Kreiseleggenzinken
Dents pour herses
Зубья ротационной бороны



Marca della macchina Machine brand name Marke der Maschine Marque de la machine Марка машины	Tipo e codice originale Type and original code Typ original hersteller Type et code d'origine Тип и оригинальный код	Codice Nr. Ref. Nr. Re. Nr. Ref. Nr. Код №	Marca della macchina Machine brand name Marke der Maschine Marque de la machine Марка машины	Tipo e codice originale Type and original code Typ original hersteller Type et code d'origine Тип и оригинальный код	Codice Nr. Ref. Nr. Re. Nr. Ref. Nr. Код №
--	--	--	--	--	--

RICAMBIO NON ORIGINALE PER MORRA-GEOROTOR	E/16 CILINDRICO	441001 gr 1100	RICAMBIO NON ORIGINALE PER MURATORI	90x15 12015800 / 12015159	268049 gr 2200
---	------------------------	------------------------------	---	--	------------------------------

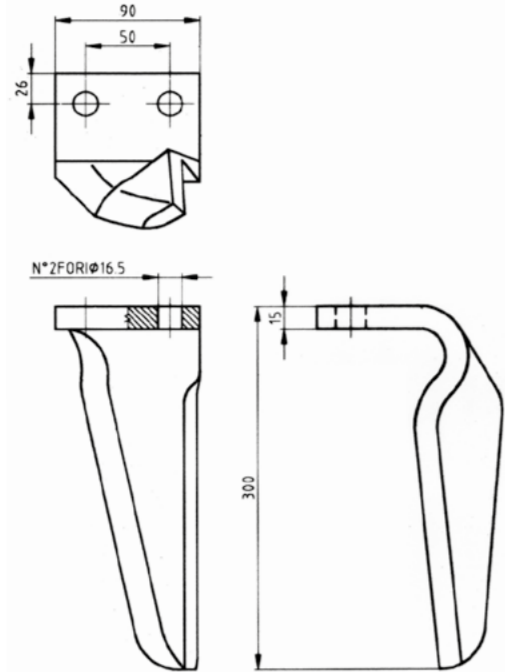
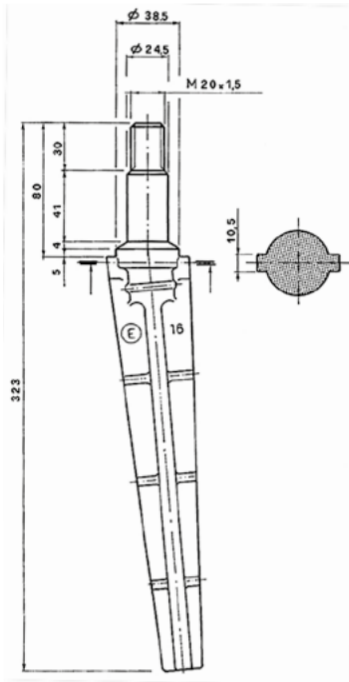

RICAMBIO NON ORIGINALE PER MURATORI	90x12 12016400 / 12016165	268050 gr 1720	RICAMBIO NON ORIGINALE PER ORTOLAN	SIRIO 80x10	292007 gr 1600
---	--	------------------------------	--	--------------------	------------------------------

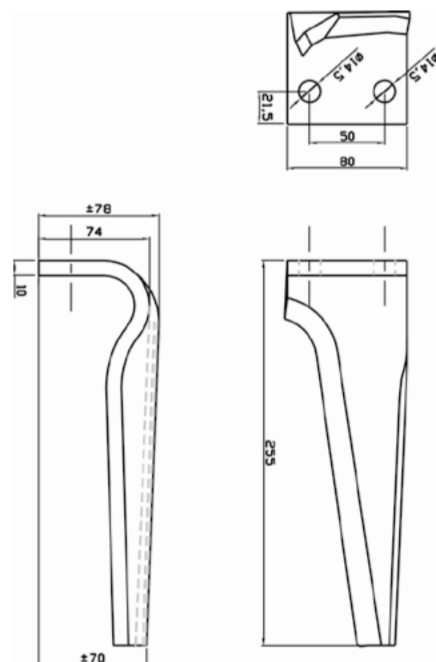
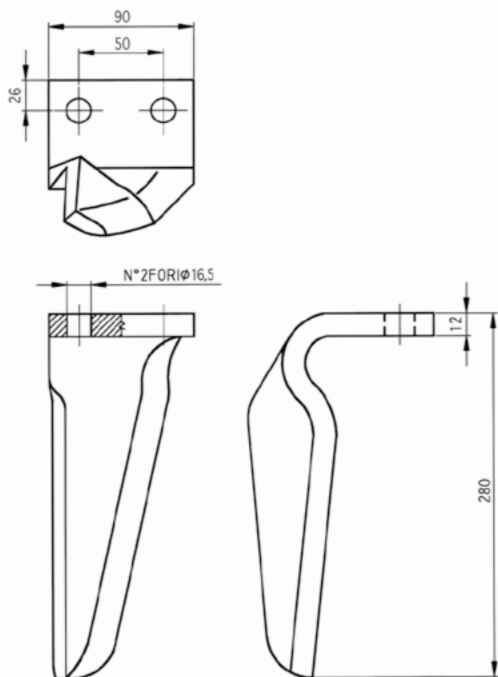

Tutti i modelli sono di nostra produzione e non originali.
 All models are of our manufacture and are not original.
 Alle unsere Landwirtschaftliche erzeugnisse sind unsere produktion und sind nicht original.
 Tous les modèles sont notre production et ne sont pas des produits d'origine.
 Все модели нашего производства и не являются оригинальными.

N.B. Pesi e misure sopra descritti sono puramente indicativi.
 N.B. The above weights and dimensions are given for reference only.
 N.B. Die obengenannten Gewichte und Abmessungen sind richtungsweisend.
 N.B. Les poids et les dimensions indiqués ci-dessus sont donnés à titre indicatif.
 N.B. Указанные вес и размеры, являются ориентировочными.

© La riproduzione anche parziale del presente catalogo è vietata.

DENTI PER ERPICE ROTANTE
Tines for rotary harrows
Kreiseleggenzinken
Dents pour herses
Зубья ротационной бороны



Marca della macchina
 Machine brand name
 Marke der Maschine
 Marque de la machine
 Марка машины

Tipo e codice originale
 Type and original code
 Typ original hersteller
 Type et code d'origine
 Тип и оригинальный код

Codice Nr.
 Ref. Nr.
 Re. Nr.
 Ref. Nr.
 Код №

Marca della macchina
 Machine brand name
 Marke der Maschine
 Marque de la machine
 Марка машины

Tipo e codice originale
 Type and original code
 Typ original hersteller
 Type et code d'origine
 Тип и оригинальный код

Codice Nr.
 Ref. Nr.
 Re. Nr.
 Ref. Nr.
 Код №

RICAMBIO NON ORIGINALE PER PEGORARO/FORT PEGORARO	DENTE RD 100x14	302031	RICAMBIO NON ORIGINALE PER PEGORARO/FORT PEGORARO	DENTE RC 100x12	302032
	007869 / 007870	gr 2350		007862 / 007863	gr 1870

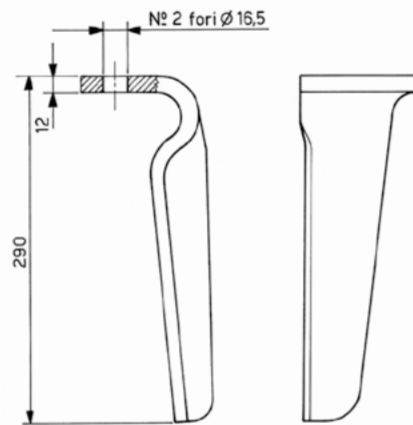
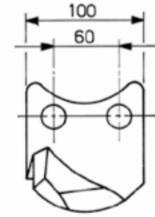
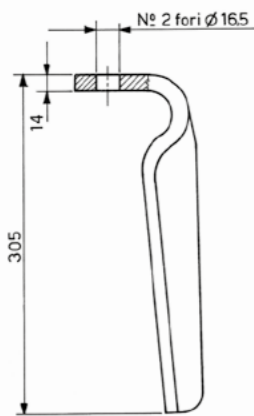
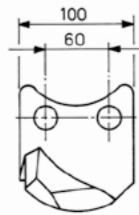

RICAMBIO NON ORIGINALE PER PEGORARO/FORT PEGORARO	100x14	302040	RICAMBIO NON ORIGINALE PER PEGORARO/FORT PEGORARO	E/21 RA	446002
		gr 2600		1205101	gr 630

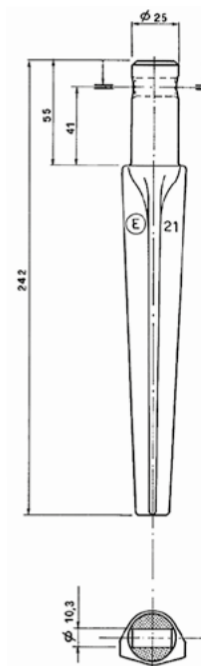
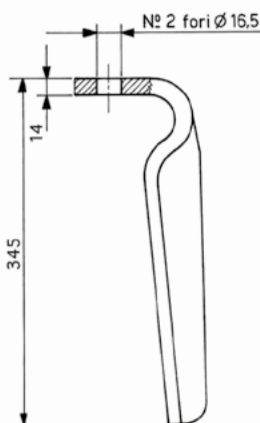
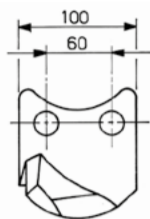

DENTI PER ERPICE ROTANTE

Tines for rotary harrows

Kreiseleggenzinken

Dents pour herses

Зубья ротационной бороны



Marca della macchina Machine brand name Marke der Maschine Marque de la machine Марка машины	Tipo e codice originale Type and original code Typ original hersteller Type et code d'origine Тип и оригинальный код	Codice Nr. Ref. Nr. Re. Nr. Ref. Nr. Код №	Marca della macchina Machine brand name Marke der Maschine Marque de la machine Марка машины	Tipo e codice originale Type and original code Typ original hersteller Type et code d'origine Тип и оригинальный код	Codice Nr. Ref. Nr. Re. Nr. Ref. Nr. Код №
--	--	--	--	--	--

RICAMBIO NON ORIGINALE PER PEGORARO/FORT PEGORARO	E/38 RC N.T. 00398101	446003 gr 1170	RICAMBIO NON ORIGINALE PER PERUGINI CONCEPT	DENTE 100x12 330414 / 330415	304010 gr 1900
---	--	------------------------------	---	---	------------------------------

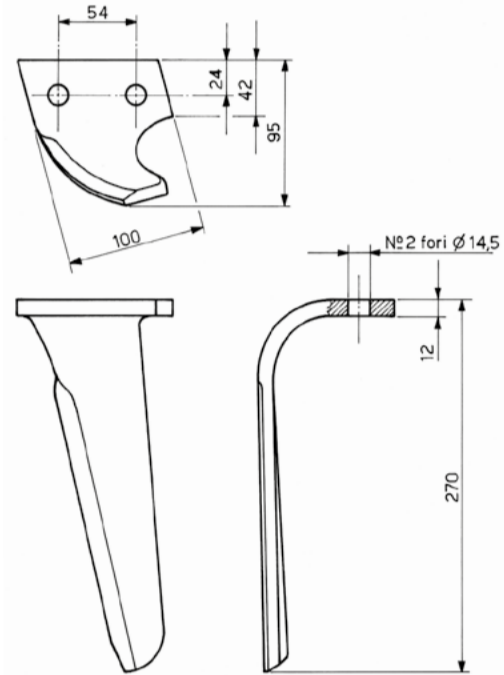
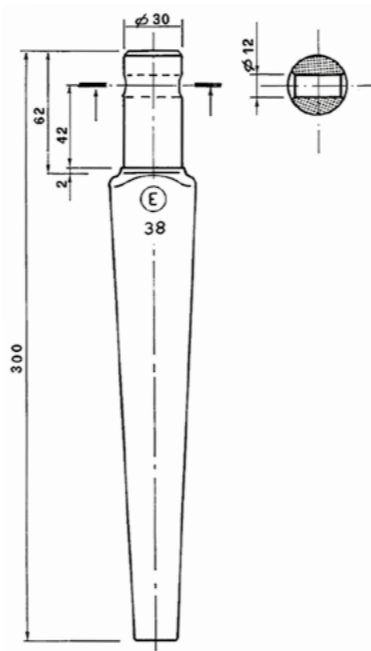

RICAMBIO NON ORIGINALE PER PERUGINI CONCEPT	100x15 320424 / 320425	304017 gr 2570	RICAMBIO NON ORIGINALE PER PERUGINI CONCEPT	KG30 DX/SX 100x15 304032	304032 gr 2380
---	---	------------------------------	---	---	------------------------------

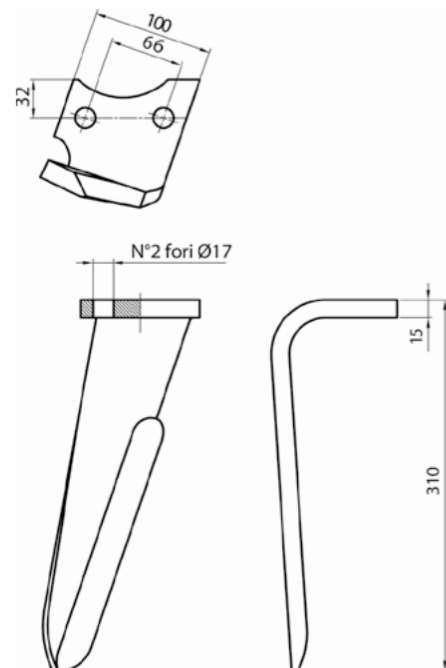
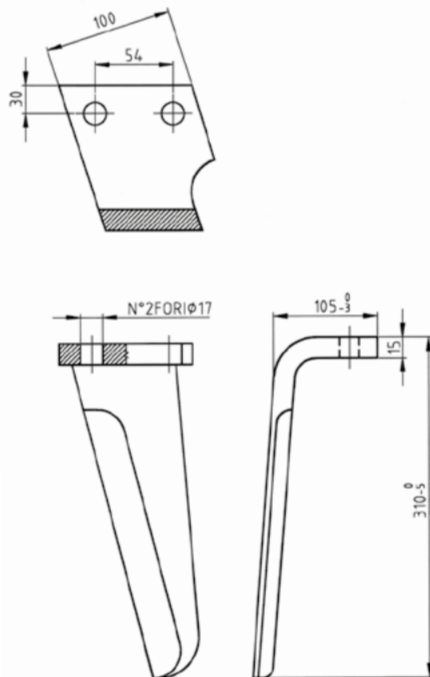

Tutti i modelli sono di nostra produzione e non originali.
 All models are of our manufacture and are not original.
 Alle unsere Landwirtschaftliche erzeugnisse sind unsere produktion und sind nicht original.
 Tous les modèles sont notre production et ne sont pas des produits d'origine.
 Все модели нашего производства и не являются оригинальными.

N.B. Pesi e misure sopra descritti sono puramente indicativi.
 N.B. The above weights and dimensions are given for reference only.
 N.B. Die obengenannten Gewichte und Abmessungen sind richtungsweisend.
 N.B. Les poids et les dimensions indiqués ci-dessus sont donnés à titre indicatif.
 N.B. Указанные вес и размеры, являются ориентировочными.

© La riproduzione
 anche parziale
 del presente catalogo
 è vietata.

DENTI PER ERPICE ROTANTE
Tines for rotary harrows
Kreiseleggenzinken
Dents pour herses
Зубья ротационной бороны



Marca della macchina
 Machine brand name
 Marke der Maschine
 Marque de la machine
 Марка машины

Tipo e codice originale
 Type and original code
 Typ original hersteller
 Type et code d'origine
 Тип и оригинальный код

Codice Nr.
 Ref. Nr.
 Re. Nr.
 Ref. Nr.
 Код №

Marca della macchina
 Machine brand name
 Marke der Maschine
 Marque de la machine
 Марка машины

Tipo e codice originale
 Type and original code
 Typ original hersteller
 Type et code d'origine
 Тип и оригинальный код

Codice Nr.
 Ref. Nr.
 Re. Nr.
 Ref. Nr.
 Код №

RICAMBIO NON ORIGINALE PER PERUGINI CONCEPT	E/2B CONICO	447001 gr 1060	RICAMBIO NON ORIGINALE PER RABEWERK	E/34 KG30 100x15 8404.50.01 / 8404.50.02	448001 448002 gr 2380
---	-------------	--------------------------	---	---	---

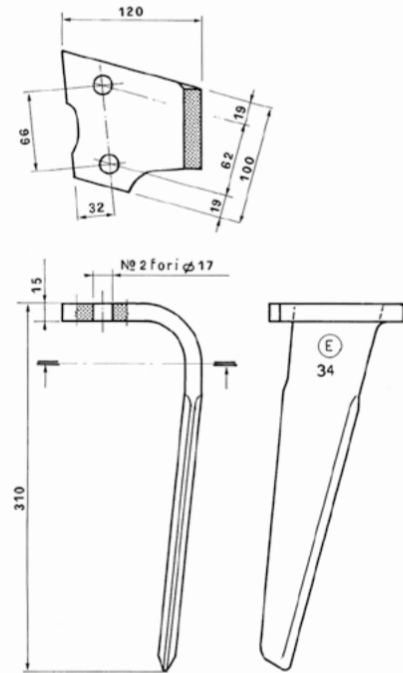
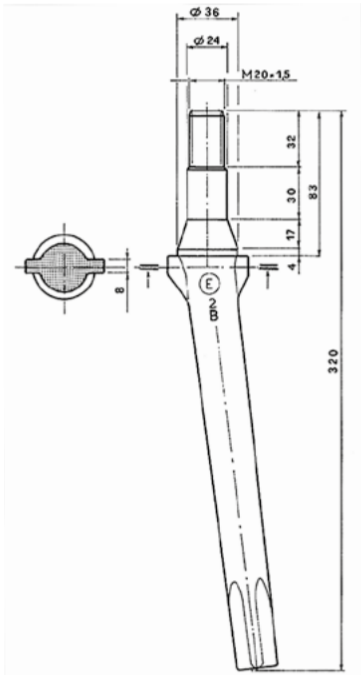

RIGHT

RICAMBIO NON ORIGINALE PER RABEWERK	KG26 80x15 8409.12.01 / 8409.12.02	448003 448004 gr 1800	RICAMBIO NON ORIGINALE PER RABEWERK	KG41 100x18 INTERASSE 65 8423.18.01 / 8423.18.02	448005 448009 gr 2950
---	---------------------------------------	---	---	--	---

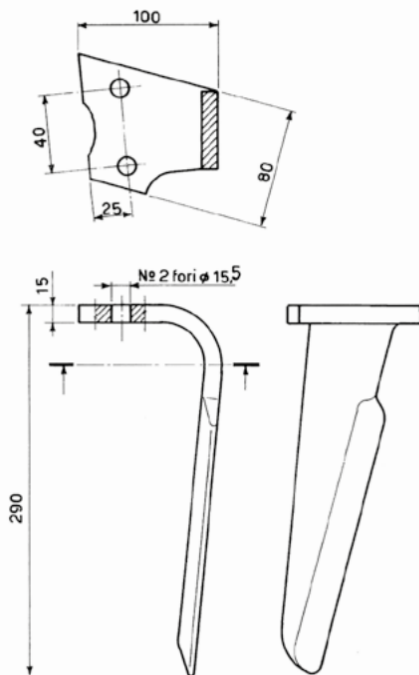

RIGHT

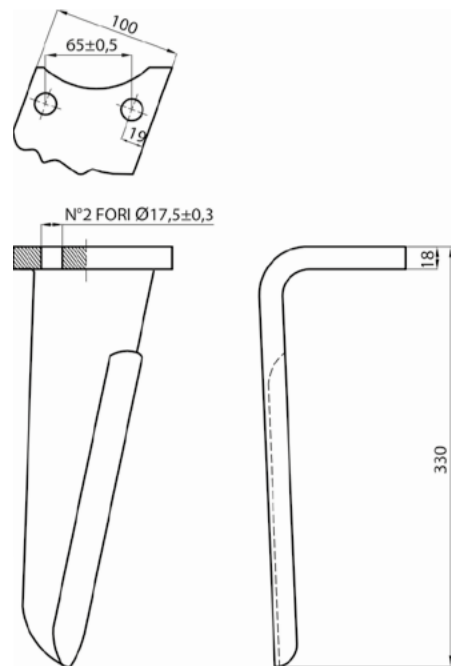

RIGHT

DENTI PER ERPICE ROTANTE
Tines for rotary harrows
Kreiseleggenzinken
Dents pour herses
Зубья ротационной бороны



Marca della macchina Machine brand name Marke der Maschine Marque de la machine Марка машины	Tipo e codice originale Type and original code Typ original hersteller Type et code d'origine Тип и оригинальный код	Codice Nr. Ref. Nr. Re. Nr. Ref. Nr. Код №	Marca della macchina Machine brand name Marke der Maschine Marque de la machine Марка машины	Tipo e codice originale Type and original code Typ original hersteller Type et code d'origine Тип и оригинальный код	Codice Nr. Ref. Nr. Re. Nr. Ref. Nr. Код №
RICAMBIO NON ORIGINALE PER RABEWERK	KG41 SOLO SX 100x18 INTERASSE 70	448006	RICAMBIO NON ORIGINALE PER RAU	ACKER 25x25	449001
		gr 2950		RG0023374	gr 720

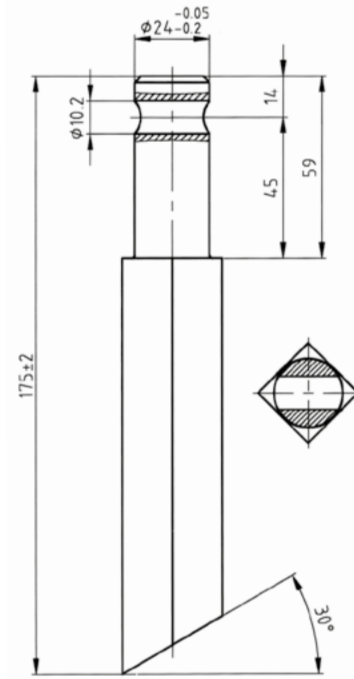
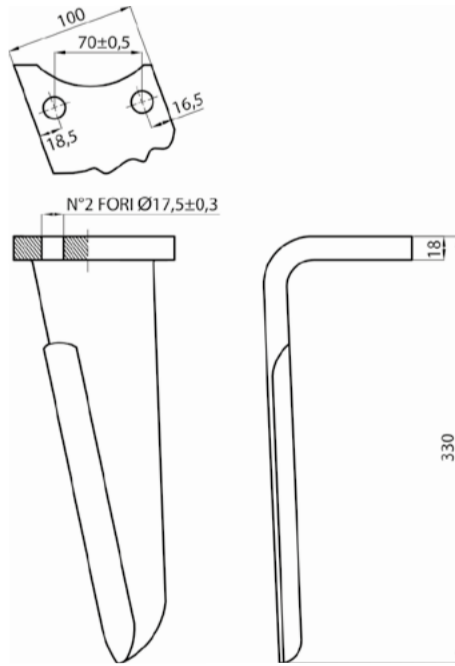

RICAMBIO NON ORIGINALE PER RAU	MULCHING 25x25	449002	RICAMBIO NON ORIGINALE PER RAU	KEILZINKEN 30x30	449003
	RG0035921	gr 900		RG0049048	gr 1100

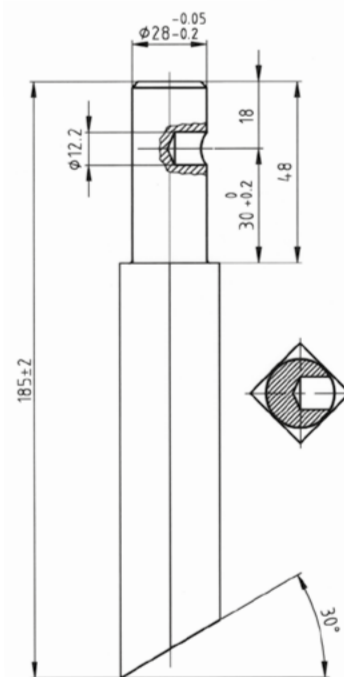
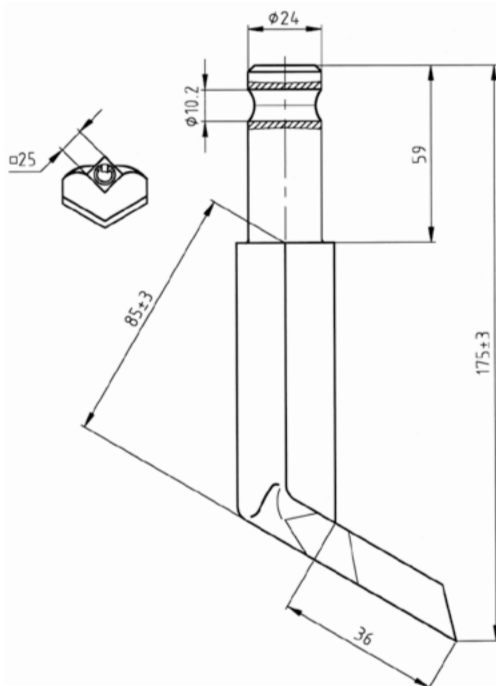

Tutti i modelli sono di nostra produzione e non originali.
 All models are of our manufacture and are not original.
 Alle unsere Landwirtschaftliche erzeugnisse sind unsere produktion und sind nicht original.
 Tous les modèles sont notre production et ne sont pas des produits d'origine.
 Все модели нашего производства и не являются оригинальными.

N.B. Pesi e misure sopra descritti sono puramente indicativi.
 N.B. The above weights and dimensions are given for reference only.
 N.B. Die obengenannten Gewichte und Abmessungen sind richtungweisend.
 N.B. Les poids et les dimensions indiqués ci-dessus sont donnés à titre indicatif.
 N.B. Указанные вес и размеры, являются ориентировочными.

© La riproduzione
 anche parziale
 del presente catalogo
 è vietata.

DENTI PER ERPICE ROTANTE
Tines for rotary harrows
Kreiseleggenzinken
Dents pour herses
Зубья ротационной бороны



Marca della macchina
 Machine brand name
 Marke der Maschine
 Marque de la machine
 Марка машины

Tipo e codice originale
 Type and original code
 Typ original hersteller
 Type et code d'origine
 Тип и оригинальный код

Codice Nr.
 Ref. Nr.
 Re. Nr.
 Ref. Nr.
 Код №

Marca della macchina
 Machine brand name
 Marke der Maschine
 Marque de la machine
 Марка машины

Tipo e codice originale
 Type and original code
 Typ original hersteller
 Type et code d'origine
 Тип и оригинальный код

Codice Nr.
 Ref. Nr.
 Re. Nr.
 Ref. Nr.
 Код №

RICAMBIO NON ORIGINALE PER RAU	DENTE QUADRO 30x30	449006	RICAMBIO NON ORIGINALE PER REMAC	E/9 CONICO CORTO	451001
	RG00035920	gr 1180			gr 1100

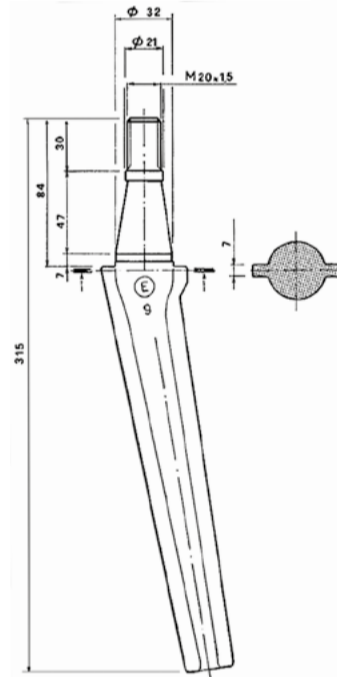
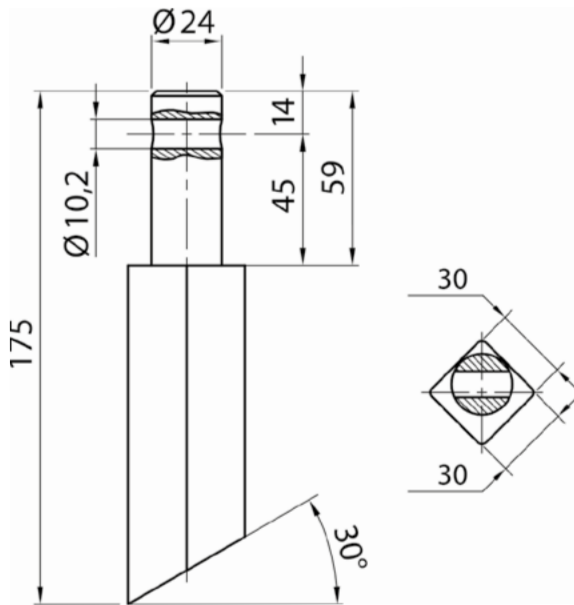

RICAMBIO NON ORIGINALE PER REMAC	E/2A CONICO MEDICO	451002	RICAMBIO NON ORIGINALE PER RINIERI	80x10	323005
		gr 1100			gr 1260

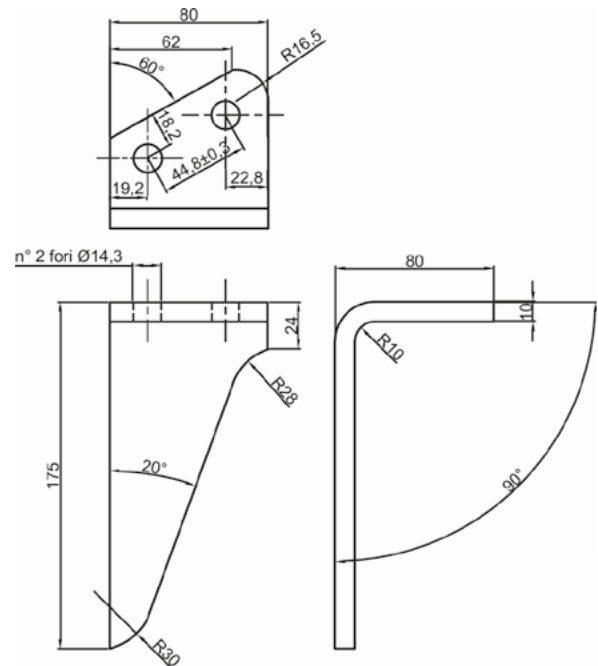
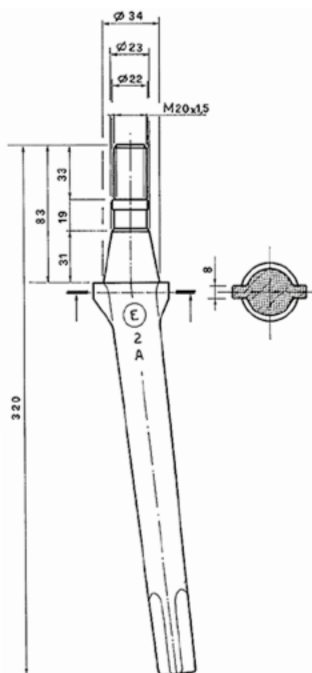

DENTI PER ERPICE ROTANTE

Tines for rotary harrows

Kreiseleggenzinken

Dents pour herses

Зубья ротационной бороны



Marca della macchina Machine brand name Marke der Maschine Marque de la machine Марка машины	Tipo e codice originale Type and original code Typ original hersteller Type et code d'origine Тип и оригинальный код	Codice Nr. Ref. Nr. Re. Nr. Ref. Nr. Код №	Marca della macchina Machine brand name Marke der Maschine Marque de la machine Марка машины	Tipo e codice originale Type and original code Typ original hersteller Type et code d'origine Тип и оригинальный код	Codice Nr. Ref. Nr. Re. Nr. Ref. Nr. Код №
RICAMBIO NON ORIGINALE PER SICMA S.R.L.	E/24	455001	RICAMBIO NON ORIGINALE PER SICMA S.R.L.	E/71 90x12	SICMA/02
		gr 1530			gr 1730

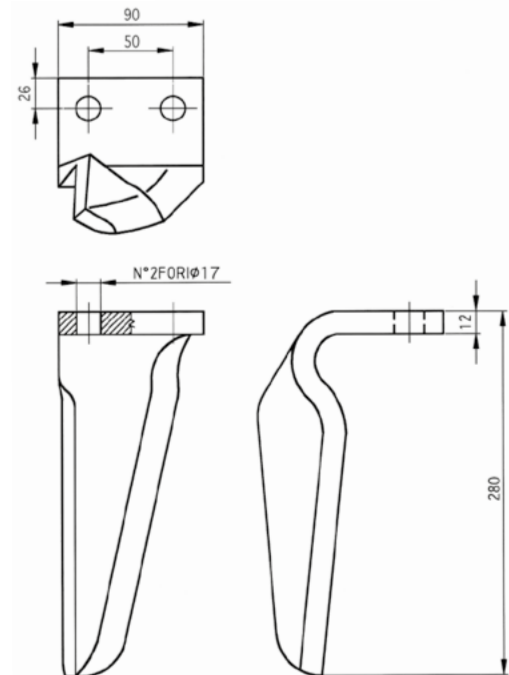
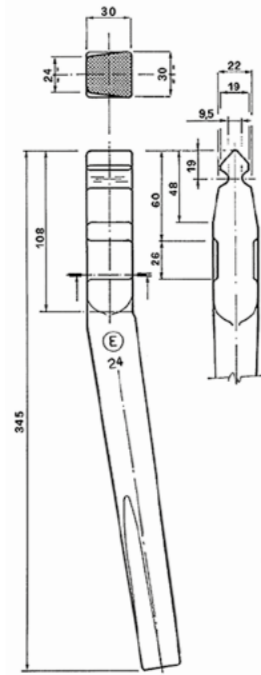

RICAMBIO NON ORIGINALE PER SICMA S.R.L.	E/114 90x14	SICMA/04	RICAMBIO NON ORIGINALE PER SOVEMA	DENTE 100x12	338019
		gr 1980		900111051 / 900111052	gr 1970

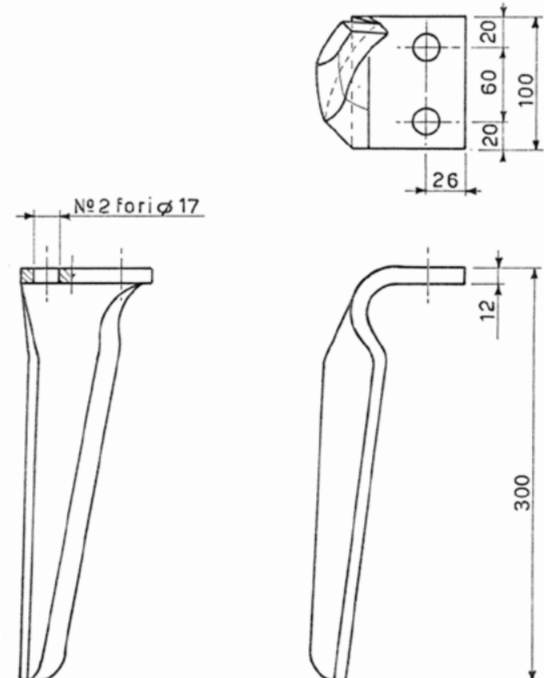
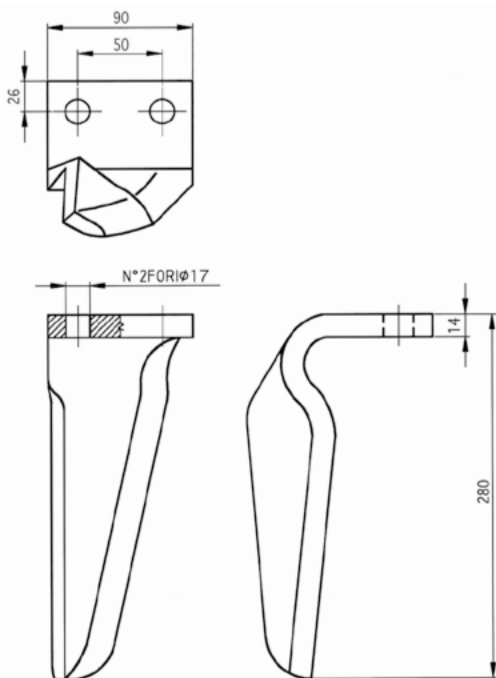

Tutti i modelli sono di nostra produzione e non originali.
 All models are of our manufacture and are not original.
 Alle unsere Landwirtschaftliche erzeugnisse sind unsere produktion und sind nicht original.
 Tous les modèles sont notre production et ne sont pas des produits d'origine.
 Все модели нашего производства и не являются оригинальными.

N.B. Pesi e misure sopra descritti sono puramente indicativi.
 N.B. The above weights and dimensions are given for reference only.
 N.B. Die obengenannten Gewichte und Abmessungen sind richtungsweisend.
 N.B. Les poids et les dimensions indiqués ci-dessus sont donnés à titre indicatif.
 N.B. Указанные вес и размеры, являются ориентировочными.

© La riproduzione
 anche parziale
 del presente catalogo
 è vietata.

DENTI PER ERPICE ROTANTE
Tines for rotary harrows
Kreiseleggenzinken
Dents pour herses
Зубья ротационной бороны



Marca della macchina
 Machine brand name
 Marke der Maschine
 Marque de la machine
 Марка машины

Tipo e codice originale
 Type and original code
 Typ original hersteller
 Type et code d'origine
 Тип и оригинальный код

Codice Nr.
 Ref. Nr.
 Re. Nr.
 Ref. Nr.
 Код №

Marca della macchina
 Machine brand name
 Marke der Maschine
 Marque de la machine
 Марка машины

Tipo e codice originale
 Type and original code
 Typ original hersteller
 Type et code d'origine
 Тип и оригинальный код

Codice Nr.
 Ref. Nr.
 Re. Nr.
 Ref. Nr.
 Код №

RICAMBIO NON ORIGINALE PER SOVEMA	DENTE 90x10	338022	RICAMBIO NON ORIGINALE PER SPAPPERI	90x12	342002
	900111056 / 900111057	gr 1400			

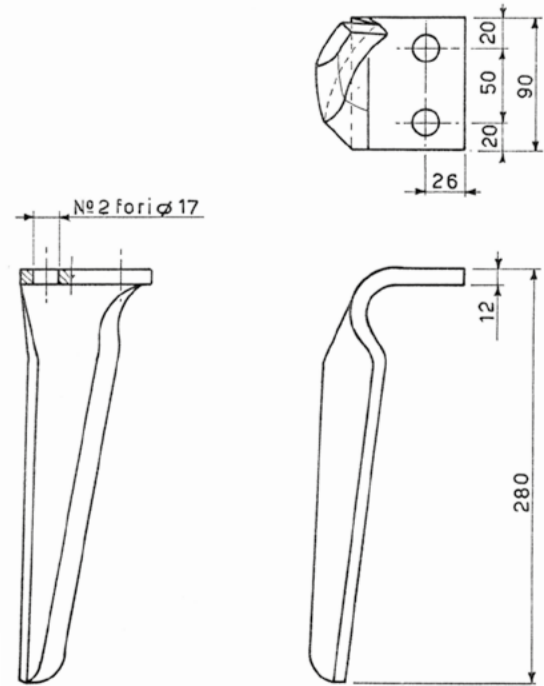
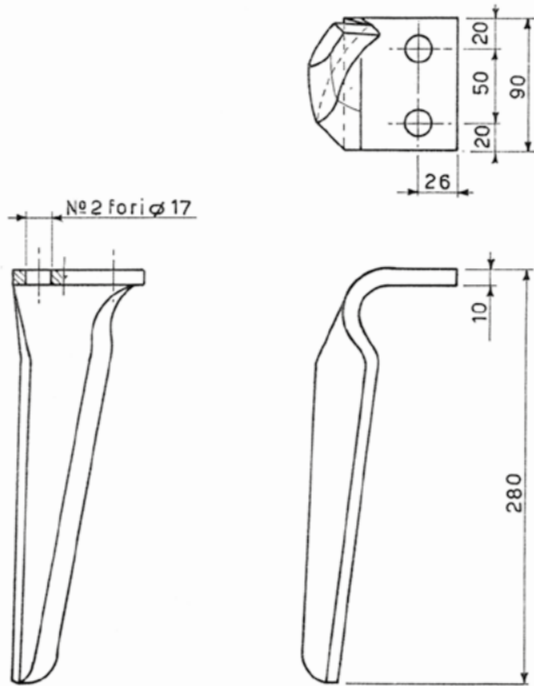

RICAMBIO NON ORIGINALE PER VIGOLO	90x12	360003	RICAMBIO NON ORIGINALE PER VIGOLO	N.T. 90x12	360013
	931010011 / 931010012	gr 1720			

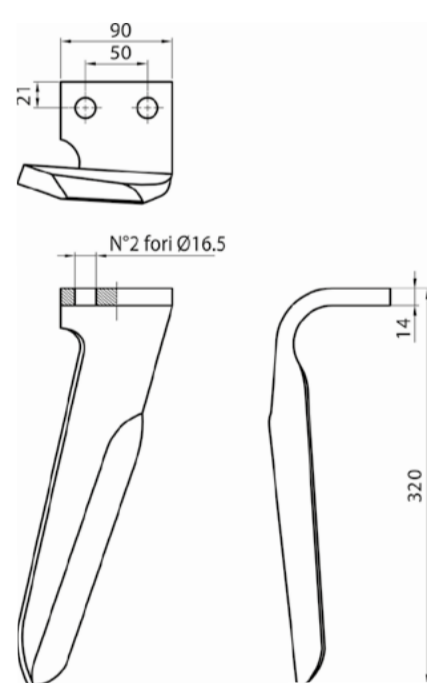
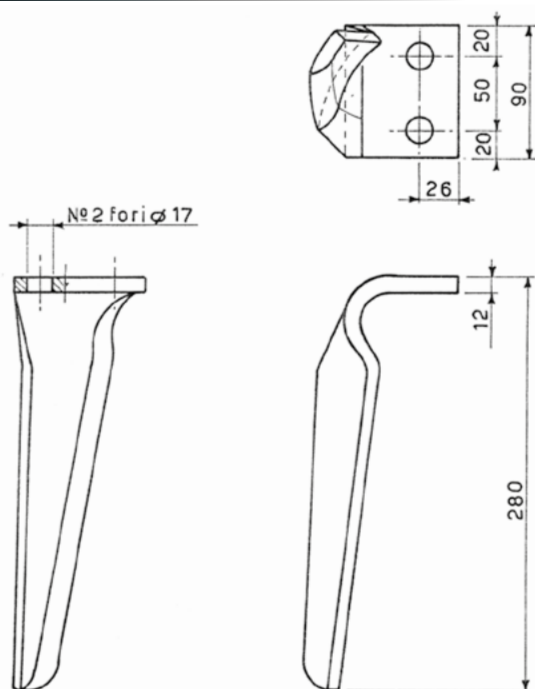



eurozappa

COLTELLI E LAME PER TRINCIA E DECESPUGLIATORI
Knives and blades for choppers and flail-mowers
Hammerschlägel und Schlägelmesser
Couteaux et lames pour hacheuses et debroussailleuses
Ножи и лезвия для мульчирователей и косилок





COLTELLI E LAME PER TRINCIA E DECESPUGLIATORI
Knives and blades for choppers and flail-mowers
Hammerschlägel und Schlägelmesser
Couteaux et lames pour hacheuses et debroussailleuses
Ножи и лезвия для мульчирователей и косилок

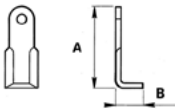

Marca della macchina Machine brand name Marke der Maschine Marque de la machine Марка машины	Codice Nr. Ref. Nr. Re. Nr. Ref. Nr. Код №		Quote Dimensions Abmessungen Dimensions Размеры mm	Curvatura Curvature Krümmung Courbure Изгиб	Piatto Plate Platte Plaque Профиль mm	Fori Holes Löcher Trous Отверстия Ø mm	Interasse Center distance Achsenabstand Entraxe Расстояние Ø - Ø	Peso Weight Gewicht Poids Вес gr
--	--	--	---	---	--	---	---	---

AEDES								
Trincia L	105010		A = 102 B = 61	—	40x10	16,5	—	380

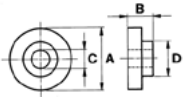
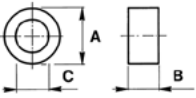
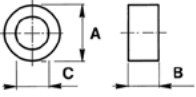
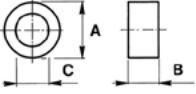
AGRAM								
Distanziale	106003		A = 50 B = 19,8 C = 13 D = 25,5	—	—	13	—	130
Boccola	140008		A = 17,5 B = 35 C = 13,2	—	—	13,5	—	25
Boccola	140009		A = 25,4 B = 39 C = 16,4	—	—	16,5	—	80
Boccola	140010		A = 22,2 B = 35 C = 13,2	—	—	13,2	—	60

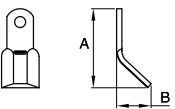
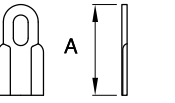
AGRICOM								
Trincia Y	108001		A = 119 B = 52	—	40x8	16,5	—	330
Trincia diritto	108002		A = 82	—	40x5	30x14	—	120

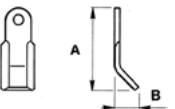
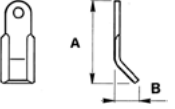
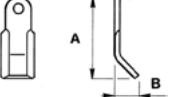
AGRIMASTER								
	112002		A = 119 B = 52	—	40x8	20,5	—	280
	112003		A = 147 B = 51	—	60x8	25,5	—	520
RMU - RMU G.L. - K8 3000106	112004		A = 147 B = 57	—	60x10	25,5	—	620

Tutti i modelli sono di nostra produzione e non originali.
 All models are of our manufacture and are not original.
 Alle unsere Landwirtschaftliche erzeugnisse sind unsere produktion und sind nicht original.
 Tous les modèles sont notre production et ne sont pas des produits d'origine.
 Все модели нашего производства и не являются оригинальными.

N.B. Pesi e misure sopra descritti sono puramente indicativi.
 N.B. The above weights and dimensions are given for reference only.
 N.B. Die obengenannten Gewichte und Abmessungen sind richtungsweisend.
 N.B. Les poids et les dimensions indiqués ci-dessus sont donnés à titre indicatif.
 N.B. Указанные вес и размеры, являются ориентировочными.

© La riproduzione
 anche parziale
 del presente catalogo
 è vietata.

COLTELLI E LAME PER TRINCIA E DECESPUGLIATORI

Knives and blades for choppers and flail-mowers

Hammerschlägel und Schlägelmesser

Couteaux et lames pour hacheuses et debroussailleuses

Ножи и лезвия для мульчирователей и косилок



Marca della macchina Machine brand name Marke der Maschine Marque de la machine Марка машины	Codice Nr. Ref. Nr. Re. Nr. Ref. Nr. Код №		Quote Dimensions Abmessungen Dimensions Размеры mm	Curvatura Curvature Krümmung Courbure Изгиб	Piatto Plate Platte Plaque Профиль mm	Fori Holes Löcher Trous Отверстия Ø mm	Interasse Center distance Achsenabstand Entraxe Расстояние Ø - Ø	Peso Weight Gewicht Poids Вес gr
Trincia MT7 Diritto RMU - RMU G.L. - K8 3000107	112005		A = 148	—	60x10	25,5	—	640
Trincia YOYO - LME GREEN	112009		A = 80 B = 25	—	35x5	14,5	—	110
Trincia dritto	112011		A = 115	—	40x8	20,5	—	260

AGRITEC								
165007	114011		A = 74 B = 35	C	30x3	11x20	—	60

ARTEMECCANICA								
	107001		A = 155 B = 48	—	60x8	26,5	—	430

B.C.S.								
Spatola 58159950	123019		A = 78 B = 72	—	70x3	12,5	—	120
Trincia dritto 58159952	123022		A = 100	—	30x3	12,5	—	70

BECCHIO								
Coltello Y	138001		A = 205 B = 52	—	60x8	25,5	—	740
Trincia dritto	138002		A = 205	—	60x8	25,5	—	700
Coltello Y V.T	138003		A = 113 B = 50	—	40x12	16,5	—	480

COLTELLI E LAME PER TRINCIA E DECESPUGLIATORI
Knives and blades for choppers and flail-mowers
Hammerschlägel und Schlägelmesser
Couteaux et lames pour hacheuses et debroussailleuses
Ножи и лезвия для мульчирователей и косилок



Marca della macchina Machine brand name Marke der Maschine Marque de la machine Марка машины	Codice Nr. Ref. Nr. Re. Nr. Ref. Nr. Код №		Quote Dimensions Abmessungen Dimensions Размеры mm	Curvatura Curvature Krümmung Courbure Изгиб	Piatto Plate Platte Plaque Профиль mm	Fori Holes Löcher Trous Отверстия Ø mm	Interasse Center distance Achsenabstand Entraxe Расстояние Ø - Ø	Peso Weight Gewicht Poids Вес gr
Coltello diritto V.T	138004		A = 113	—	40×15	16,5	—	510
Coltello Y	138005		A = 205 B = 52	—	60×10	25,5	—	930
Paletta ventilante	138007		A = 190 B = 52	—	100×8	28,5	—	1520
Paletta ventilante	138017		A = 183 B = 52	—	30×8	25,5	—	450
Trincia Y	138021		A = 107 B = 43	—	40×8	25×14	—	280
Trincia Y	138024		A = 106 B = 50	—	40×12	19,5	—	440
Trincia diritto	138025		A = 106	—	40×15	19,5	—	450

BERTI								
Trincia Y	131001		A = 195 B = 50	—	60×8	28,5	—	680
Trincia diritto	131002		A = 205	—	60×8	28,5	—	710
Trincia Y lungo	131003		A = 205 B = 50	—	60×8	28,5	—	730
Boccola	131005		A = 28 B = 40 C = 21	—	—	21	—	90
Paletta ventilante lungo	131009		A = 175 B = 30	—	25×6	28,5	—	190
Trincia Y	131015		A = 196 B = 53	—	60×8	28,5	—	710

Tutti i modelli sono di nostra produzione e non originali.
 All models are of our manufacture and are not original.
 Alle unsere Landwirtschaftliche erzeugnisse sind unsere produktion und sind nicht original.
 Tous les modèles sont notre production et ne sont pas des produits d'origine.
 Все модели нашего производства и не являются оригинальными.

N.B. Pesi e misure sopra descritti sono puramente indicativi.
 N.B. The above weights and dimensions are given for reference only.
 N.B. Die obengenannten Gewichte und Abmessungen sind richtungsweisend.
 N.B. Les poids et les dimensions indiqués ci-dessus sont donnés à titre indicatif.
 N.B. Указанные вес и размеры, являются ориентировочными.

© La riproduzione
 anche parziale
 del presente catalogo
 è vietata.

COLTELLI E LAME PER TRINCIA E DECESPUGLIATORI

Knives and blades for choppers and flail-mowers

Hammerschlägel und Schlägelmesser

Couteaux et lames pour hacheuses et debroussailleuses



Ножи и лезвия для мульчирователей и косилок



Marca della macchina Machine brand name Marke der Maschine Marque de la machine Марка машины	Codice Nr. Ref. Nr. Re. Nr. Ref. Nr. Код №		Quote Dimensions Abmessungen Dimensions Размеры mm	Curvatura Curvature Krümmung Courbure Изгиб	Piatto Plate Platte Plaque Профиль mm	Fori Holes Löcher Trous Отверстия Ø mm	Interasse Center distance Achsenabstand Entraxe Расстояние Ø - Ø	Peso Weight Gewicht Poids Вес gr
Trincia diritto	131016		A = 196	—	60x8	28,5	—	680
BOMFORD								
	132001		A = 85 B = 34	—	40x6	16x32	—	160
Cavallotto	151030		A = 60 B = 47	—	Ø 13	16,5	—	135
BRUNI								
Coltello ½ giro	137001		A = 160 B = 52 C = 10	—	40x10	20,5	—	450
Coltello taglia erba	137002		A = 150 B = 42	—	45x5	20,5	—	240
Boccola Ø 20	137003		A = 20,2 B = 12 C = 12	—	—	12	—	20
BF 2	137006		A = 187 B = 52	—	40x8	12,5	45	460
Distanziale	137012		A = 30 B = 6 C = 20,5	—	—	20,5	—	24
Boccola	137013		A = 20 B = 16 C = 12,5	—	—	12,5	—	30
Coltello ½ giro n.t. foro 20,5	137015		A = 160 B = 52 C = 10	—	50x10	20,5	—	560
Coltello ½ giro n.t. foro 27,5	137016		A = 160 B = 52 C = 10	—	50x10	27,5	—	560

COLTELLI E LAME PER TRINCIA E DECESPUGLIATORI
Knives and blades for choppers and flail-mowers
Hammerschlägel und Schlägelmesser
Couteaux et lames pour hacheuses et debroussailleuses
Ножи и лезвия для мульчирователей и косилок

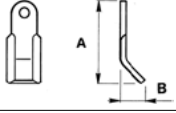
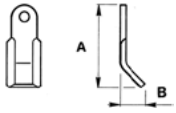
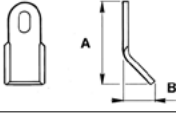
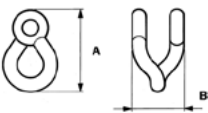
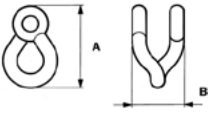
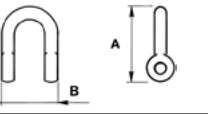
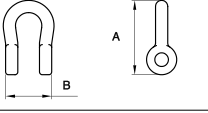
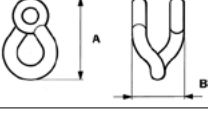
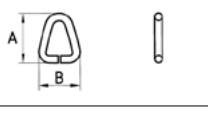
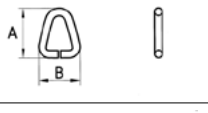

Marca della macchina Machine brand name Marke der Maschine Marque de la machine Марка машины	Codice Nr. Ref. Nr. Re. Nr. Ref. Nr. Код №		Quote Dimensions Abmessungen Dimensions Размеры mm	Curvatura Curvature Krümmung Courbure Изгиб	Piatto Plate Platte Plaque Профиль mm	Fori Holes Löcher Trous Отверстия Ø mm	Interasse Center distance Achsenabstand Entraxe Расстояние Ø - Ø	Peso Weight Gewicht Poids Вес gr
CABE								
Coltello Y 000185	143001		A = 230 B = 55	—	60x7	28,5	—	680
CARONI								
05001250	145003		A = 125 B = 35	—	40x5	10	—	190
10007440	145004		A = 80 B = 38	—	40x5	27x13	—	120
CAVALLOTTO								
Cavallo giro	151001		A = 63 B = 48	—	Ø 11	11,5	—	150
Cavallo giro	151002		A = 73 B = 49	—	Ø 13	15	—	230
Cavallo TerraNova T18004065	151009		A = 45 B = 39	—	Ø 8	9	—	60
Cavallo bombato Orsi	151010		A = 79 B = 49	—	Ø 13	14,5	—	240
Cavallo giro Ferri	151012		A = 63 B = 48	—	Ø 11	12,5	—	145
Cavallo	151014		A = 60 B = 62	—	Ø 13	—	—	160
Cavallo John Deer	151015		A = 54 B = 60	—	Ø 11	—	—	110
Brida per cavallo 151014	151016		A = 51 B = 32	—	32x6,5	13,5	—	160

Tutti i modelli sono di nostra produzione e non originali.
 All models are of our manufacture and are not original.
 Alle unsere Landwirtschaftliche erzeugnisse sind unsere produktion und sind nicht original.
 Tous les modèles sont notre production et ne sont pas des produits d'origine.
 Все модели нашего производства и не являются оригинальными.

N.B. Pesi e misure sopra descritti sono puramente indicativi.
 N.B. The above weights and dimensions are given for reference only.
 N.B. Die obengenannten Gewichte und Abmessungen sind richtungsweisend.
 N.B. Les poids et les dimensions indiqués ci-dessus sont donnés à titre indicatif.
 N.B. Указанные вес и размеры, являются ориентировочными.

© La riproduzione
 anche parziale
 del presente catalogo
 è vietata.

COLTELLI E LAME PER TRINCIA E DECESPUGLIATORI

Knives and blades for choppers and flail-mowers

Hammerschlägel und Schlägelmesser

Couteaux et lames pour hacheuses et debroussailleuses

Ножи и лезвия для мульчирователей и косилок



Marca della macchina Machine brand name Marke der Maschine Marque de la machine Марка машины	Codice Nr. Ref. Nr. Re. Nr. Ref. Nr. Код №		Quote Dimensions Abmessungen Dimensions Размеры mm	Curvatura Curvature Krümmung Courbure Изгиб	Piatto Plate Platte Plaque Профиль mm	Fori Holes Löcher Trous Отверстия Ø mm	Interasse Center distance Achsenabstand Entraxe Расстояние Ø - Ø	Peso Weight Gewicht Poids Вес gr
Cavallotto bombato	151024		A = 73 B = 48	—	Ø 11	12,5	—	120
Cavallotto	151025		A = 71 B = 49	—	Ø 13	15,5	—	170
Cavallotto	151026		A = 70 B = 73	—	Ø 13	13,5	—	160
Cavallotto	151030		A = 60 B = 47	—	Ø 13	16,5	—	135
Cavallotto M21700404	151032		A = 71,5 B = 49	—	Ø 13	14,5	—	196
Cavallotto Maletti FM-FX 6200079	252018		A = 64 B = 34	—	Ø 10	12,5	—	100
Cavallotto Sicma	333023		A = 63 B = 48	—	Ø 11	12,5	—	105
Cavallotto Sma	336004		A = 63 B = 48	—	Ø 11	11,5	—	130

CELLI

Trincia Y 702611	153053		A = 123 B = 53	—	50×10	16,5	—	470
Diritto 702612	153054		A = 123	—	50×10	16,5	—	430

DEL MORINO

Flipper Fanny URC405D	165018		A = 87 B = 40	—	35×5	14,5	—	140
Flash SOL200D	165020		A = 220 B = 48	—	50×6	10,5	80	520

COLTELLI E LAME PER TRINCIA E DECESPUGLIATORI
Knives and blades for choppers and flail-mowers
Hammerschlägel und Schlägelmesser
Couteaux et lames pour hacheuses et debroussailleuses
Ножи и лезвия для мульчирователей и косилок



Marca della macchina Machine brand name Marke der Maschine Marque de la machine Марка машины	Codice Nr. Ref. Nr. Re. Nr. Ref. Nr. Код №	Quote Dimensions Abmessungen Dimensions Размеры mm	Curvatura Curvature Krümmung Courbure Изгиб	Piatto Plate Platte Plaque Профиль mm	Fori Holes Löcher Trous Отверстия Ø mm	Interasse Center distance Achsenabstand Entraxe Расстояние Ø - Ø	Peso Weight Gewicht Poids Вес gr
--	--	---	---	--	---	---	---

DESVOYS

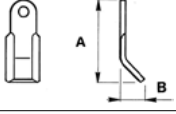
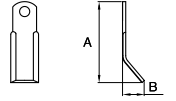
	167001		A = 215 B = 56	—	60x8	25,5	—	860
Trincia Y	167002		A = 204 B = 55	—	60x8	25,5	—	780

EPOKE

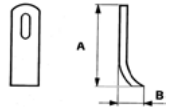
	173001		A = 122 B = 37	—	40x10	14x39	—	340
--	--------	--	-------------------	---	-------	-------	---	-----

FALC

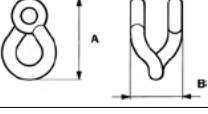
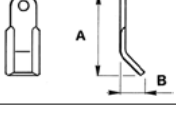
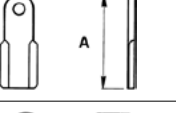
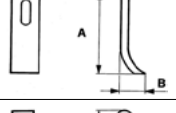
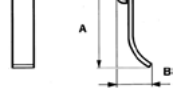
Cavallotto girato 470301	151002		A = 73 B = 49	—	Ø 13	15	—	230
Trincia tipo Alce Y 430151	181002		A = 205 B = 52	—	60x10	25,5	—	960
Trincia 02 diritto 430083	181014		A = 205	—	60x10	25,5	—	930
Coltello snodato 470307	181024		A = 98 B = 39	—	40x12	16x36	—	330
Paletta ventilante Alce 430853	181031		A = 160 B = 46	—	34x8	26	—	500

FERRI

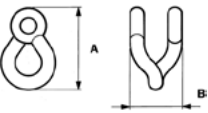
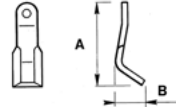
Cavallotto girato	151001		A = 63 B = 48	—	Ø 11	11,5	—	150
Universale 0901001	187001		A = 247 B = 66	—	60x8	25,5	—	960

Tutti i modelli sono di nostra produzione e non originali.
 All models are of our manufacture and are not original.
 Alle unsere Landwirtschaftliche erzeugnisse sind unsere produktion und sind nicht original.
 Tous les modèles sont notre production et ne sont pas des produits d'origine.
 Все модели нашего производства и не являются оригинальными.

N.B. Pesi e misure sopra descritti sono puramente indicativi.
 N.B. The above weights and dimensions are given for reference only.
 N.B. Die obengenannten Gewichte und Abmessungen sind richtungsweisend.
 N.B. Les poids et les dimensions indiqués ci-dessus sont donnés à titre indicatif.
 N.B. Указанные вес и размеры, являются ориентировочными.

© La riproduzione
 anche parziale
 del presente catalogo
 è vietata.

COLTELLI E LAME PER TRINCIA E DECESPUGLIATORI

Knives and blades for choppers and flail-mowers

Hammerschlägel und Schlägelmesser

Couteaux et lames pour hacheuses et debroussailleuses

Ножи и лезвия для мульчирователей и косилок



Marca della macchina Machine brand name Marke der Maschine Marque de la machine Марка машины	Codice Nr. Ref. Nr. Re. Nr. Ref. Nr. Код №		Quote Dimensions Abmessungen Dimensions Размеры mm	Curvatura Curvature Krümmung Courbure Изгиб	Piatto Plate Platte Plaque Профиль mm	Fori Holes Löcher Trous Отверстия Ø mm	Interasse Center distance Achsenabstand Entraxe Расстояние Ø - Ø	Peso Weight Gewicht Poids Вес gr
Angolato 0901005	187004		A = 245 B = 75	SQ	60x8	25,5	—	1040
Decespugliatore 45°	187005		A = 150 B = 62	—	60x8	25,5	—	530
Y lungo 0901004	187006		A = 240 B = 62	—	60x8	25,5	—	910
Boccola per Decespugliatore	187009		A = 25 B = 19 C = 17	—	—	17	—	50
Boccola per Universale	187010		A = 25 B = 28 C = 17	—	—	17	—	75
Coltello snodato 0901049	187014		A = 81 B = 38	—	40x8	14x30	—	220
Boccola	187015		A = 25 B = 44 C = 17,5	—	—	17,5	—	90
Coltello snodato 0901068	187016		A = 100 B = 38	—	40x8	17x35	—	260
Cavallotto	187017		A = 63 B = 48	—	Ø 11	11,5	—	130
Boccola 1101028	187021		A = 20 B = 22 C = 12,5	—	—	12,5	—	45
Boccola 1101016	187022		A = 25 B = 64 C = 12,5	—	—	12,5	—	180
Distanziale 1101019	187024		A = 51 B = 12,8 C = 25	—	—	25,5	—	160
Trincia Y polivalente leggero 0901129	187023		A = 128 B = 60	—	40x8	16,5	—	350
Decespugliatore 45° NT 0901003 Battuta stretta	187026		A = 145 B = 50	—	60x8	25,5	—	510

COLTELLI E LAME PER TRINCIA E DECESPUGLIATORI
Knives and blades for choppers and flail-mowers
Hammerschlägel und Schlägelmesser
Couteaux et lames pour hacheuses et debroussailleuses
Ножи и лезвия для мульчирователей и косилок



Marca della macchina Machine brand name Marke der Maschine Marque de la machine Марка машины	Codice Nr. Ref. Nr. Re. Nr. Ref. Nr. Код №		Quote Dimensions Abmessungen Dimensions Размеры mm	Curvatura Curvature Krümmung Courbure Изгиб	Piatto Plate Platte Plaque Профиль mm	Fori Holes Löcher Trous Отверстия Ø mm	Interasse Center distance Achsenabstand Entraxe Расстояние Ø - Ø	Peso Weight Gewicht Poids Вес gr
Trincia diritto TS 0901148	187027		A = 150	—	60x8	25,5	—	510
Trincia Y	187028		A = 100 B = 38	—	40x6	35x17	—	220
Boccola 110.10.34	187030		A = 51 B = 9,4 C = 25,3	—	—	25,3	—	115
Boccola 1101017	187031		A = 35 B = 7,8 C = 12,5	—	—	12,5	—	50
Trincia Y lungo 09011068	187032		A = 102 B = 43	—	40x8	30x14	—	270
Trincia Y 0901158	187036		A = 130 B = 40	—	40x6	12,5	—	250
Trincia diritto 0901159	187037		A = 130	—	40x6	12,5	—	230
Trincia diritto 901153	187039		A = 104	—	40x6	35x17	—	180
0901146	187041		A = 130 B = 41	—	50x8	16,5	—	420

HEMOS

	229001		A = 100 B = 25	—	50x10	19x36	—	320
--	--------	--	-------------------	---	-------	-------	---	-----

HERMES

	201001		A = 91 B = 33	—	30x5	23x10	—	110
--	--------	--	------------------	---	------	-------	---	-----

Tutti i modelli sono di nostra produzione e non originali.
 All models are of our manufacture and are not original.
 Alle unsere Landwirtschaftliche erzeugnisse sind unsere produktion und sind nicht original.
 Tous les modèles sont notre production et ne sont pas des produits d'origine.
 Все модели нашего производства и не являются оригинальными.

N.B. Pesi e misure sopra descritti sono puramente indicativi.
 N.B. The above weights and dimensions are given for reference only.
 N.B. Die obengenannten Gewichte und Abmessungen sind richtungsweisend.
 N.B. Les poids et les dimensions indiqués ci-dessus sont donnés à titre indicatif.
 N.B. Указанные вес и размеры, являются ориентировочными.

© La riproduzione
 anche parziale
 del presente catalogo
 è vietata.

COLTELLI E LAME PER TRINCIA E DECESPUGLIATORI
Knives and blades for choppers and flail-mowers
Hammerschlägel und Schlägelmesser
Couteaux et lames pour hacheuses et debroussailleuses
Ножи и лезвия для мульчирователей и косилок

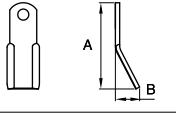

Marca della macchina Machine brand name Marke der Maschine Marque de la machine Марка машины	Codice Nr. Ref. Nr. Re. Nr. Ref. Nr. Код №	Quote Dimensions Abmessungen Dimensions Размеры mm	Curvatura Curvature Krümmung Courbure Изгиб	Piatto Plate Platte Plaque Профиль mm	Fori Holes Löcher Trous Отверстия Ø mm	Interasse Center distance Achsenabstand Entraxe Расстояние Ø - Ø	Peso Weight Gewicht Poids Вес gr	
HMF								
	196006		A = 107 B = 43	—	40×10	17	—	360
HUMUS								
	227001		A = 135 B = 52	—	50×8	16,5	—	480
HYMACH								
024A	150011		A = 105 B = 47	—	40×8	14×27	—	280
024-U	150025		A = 85 B = 42	—	40×5	10,5	—	120
Trincia svirgolato 024S	150026		A = 156 B = 66 C = 10	—	50×12	20,5	—	650
Trincia Y 024G	150027		A = 160 B = 45	—	50×8	20,5	—	500
JF								
Paletta 2129-234	233001		A = 116 B = 40	—	90×6	12,5	—	580
Brida 2129-235	233002		A = 105	—	65×6,5	12,5	—	740
JOHN DEERE								
	357001		A = 85 B = 70	—	70×3	14×19	—	160

COLTELLI E LAME PER TRINCIA E DECESPUGLIATORI
Knives and blades for choppers and flail-mowers
Hammerschlägel und Schlägelmesser
Couteaux et lames pour hacheuses et debroussailleuses
Ножи и лезвия для мульчирователей и косилок



Marca della macchina Machine brand name Marke der Maschine Marque de la machine Марка машины	Codice Nr. Ref. Nr. Re. Nr. Ref. Nr. Код №		Quote Dimensions Abmessungen Dimensions Размеры mm	Curvatura Curvature Krümmung Courbure Изгиб	Piatto Plate Platte Plaque Профиль mm	Fori Holes Löcher Trous Отверстия Ø mm	Interasse Center distance Achsenabstand Entraxe Расстояние Ø - Ø	Peso Weight Gewicht Poids Вес gr
	357002		A = 69 B = 70	—	70x3	14x19	—	150

KUHN								
A54112340	237029		A = 93 B = 37	—	35x8	30x16	—	210

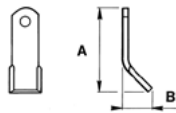
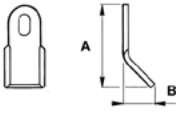
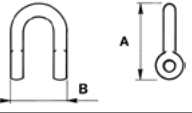
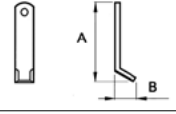
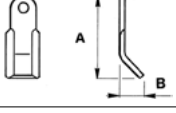
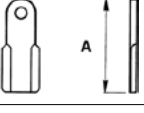
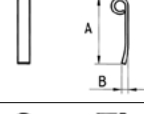
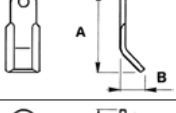
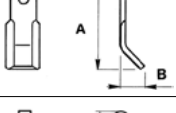
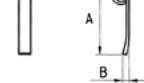
KVERNELAND								
FM-FH universale 6200080	252015		A = 125 B = 35	—	40x5	14,5	—	200
Coltello per sassi FM-FH 6200078	252016		A = 78 B = 39	—	40x5	14x26	—	120
Cavallotto FM-FX 6200079	252018		A = 64 B = 34	—	Ø 10	12,5	—	100
Coltello FL universale 6101080	252020		A = 130 B = 28	—	30x3	11	—	80
Trincia universale FX a Y 6400080	252021		A = 196 B = 54	—	50x10	16,5	—	780
Trincia paglia FX diritto 6400079	252022		A = 200	—	50x10	16,5	—	700
Paletta ventilante 6401077	252034		A = 192 B = 33	—	30x8	18	—	450
	252039		A = 130 B = 40	—	40x10	16,5	—	400
FH pesante	252047		A = 134 B = 40	—	40x10	14,5	—	420
Paletta ventilante 6400077	252053		A = 119 B = 33	—	30x5	18	—	220

Tutti i modelli sono di nostra produzione e non originali.
 All models are of our manufacture and are not original.
 Alle unsere Landwirtschaftliche erzeugnisse sind unsere produktion und sind nicht original.
 Tous les modèles sont notre production et ne sont pas des produits d'origine.
 Все модели нашего производства и не являются оригинальными.

N.B. Pesi e misure sopra descritti sono puramente indicativi.
 N.B. The above weights and dimensions are given for reference only.
 N.B. Die obengenannten Gewichte und Abmessungen sind richtungsweisend.
 N.B. Les poids et les dimensions indiqués ci-dessus sont donnés à titre indicatif.
 N.B. Указанные вес и размеры, являются ориентировочными.

© La riproduzione
 anche parziale
 del presente catalogo
 è vietata.

COLTELLI E LAME PER TRINCIA E DECESPUGLIATORI

Knives and blades for choppers and flail-mowers

Hammerschlägel und Schlägelmesser

Couteaux et lames pour hacheuses et debroussailleuses

Ножи и лезвия для мульчирователей и косилок



Marca della macchina Machine brand name Marke der Maschine Marque de la machine Марка машины	Codice Nr. Ref. Nr. Re. Nr. Ref. Nr. Код №		Quote Dimensions Abmessungen Dimensions Размеры mm	Curvatura Curvature Krümmung Courbure Изгиб	Piatto Plate Platte Plaque Профиль mm	Fori Holes Löcher Trous Отверстия Ø mm	Interasse Center distance Achsenabstand Entraxe Расстояние Ø - Ø	Peso Weight Gewicht Poids Вес gr
Paletta ventilante 6402077	252073		A = 190 B = 42	—	100×8	18	—	990
Trincia 7800080	252079		A = 130 B = 50	—	40×10	16,5	—	400
Portacoltello 64010024	252087		A = 50 B = 25	—	70×10	16,5	—	560

LAGARDE

1343.01	238002		A = 245 B = 60	—	60×8	25,5	—	950
Paletta ventilante 1344.01	238003		A = 213 B = 67	—	30×8	25,5	—	380
	238004		A = 142 B = 40	—	50×10	18,5	—	560
	238008		A = 245 B = 60	—	60×7	25,5	—	830
	238009		A = 210 B = 55	—	60×8	25,5	—	800

MASCHIO

Cavallotto T18004065	151009		A = 46 B = 42	—	Ø 8	9	—	60
Cavallotto M21700404	151032		A = 71,5 B = 49	—	Ø 13	14,5	—	190
Trincia	255042		A = 124 B = 65	—	60×10	20,5	—	700
	255062		A = 155 B = 58	—	60×10	20,5	—	720

COLTELLI E LAME PER TRINCIA E DECESPUGLIATORI
Knives and blades for choppers and flail-mowers
Hammerschlägel und Schlägelmesser
Couteaux et lames pour hacheuses et debroussailleuses
Ножи и лезвия для мульчирователей и косилок



Marca della macchina Machine brand name Marke der Maschine Marque de la machine Марка машины	Codice Nr. Ref. Nr. Re. Nr. Ref. Nr. Код №		Quote Dimensions Abmessungen Dimensions Размеры mm	Curvatura Curvature Krümmung Courbure Изгиб	Piatto Plate Platte Plaque Профиль mm	Fori Holes Löcher Trous Отверстия Ø mm	Interasse Center distance Achsenabstand Entraxe Расстояние Ø - Ø	Peso Weight Gewicht Poids Вес gr
Trincia Y M03400406	255076		A = 115 B = 60	—	50×10	20,5	—	500
Paletta ventilante T40005143	348001		A = 175 B = 58	—	30×8	25,5	—	520
Trincia Y T21004040	348002		A = 130 B = 61	—	45×8	16,5	—	450
Trincia diritto T21004050	348003		A = 130	—	45×8	16,5	—	340
Trincia squadro T40004068	348005		A = 210 B = 60	SQ	60×8	25,5	—	870
Coltello TV T18004060	348006		A = 82 B = 36	—	40×5	13×26	—	120
Trincia Y lungo T40005142	348009		A = 210 B = 61	—	60×8	25,5	—	740
Trincia diritto T40005141	348010		A = 210	—	60×8	25,5	—	700
Spatola T18004085	348011		A = 69 B = 70	—	70×3	14×19	—	150

MEAAT								
Trincia a Y 1361	259005		A = 205 B = 52	—	60×10	25,5	—	1000
Trinciastocchi diritto	259008		A = 205	—	60×10	25,5	—	1000
Boccola	259019		A = 25 B = 16 C = 17	—	—	17	—	40
TSA/R-150 2491	259020		A = 98 B = 45	—	40×8	14×30	—	280

Tutti i modelli sono di nostra produzione e non originali.
 All models are of our manufacture and are not original.
 Alle unsere Landwirtschaftliche erzeugnisse sind unsere produktion und sind nicht original.
 Tous les modèles sont notre production et ne sont pas des produits d'origine.
 Все модели нашего производства и не являются оригинальными.

N.B. Pesi e misure sopra descritti sono puramente indicativi.
 N.B. The above weights and dimensions are given for reference only.
 N.B. Die obengenannten Gewichte und Abmessungen sind richtungsweisend.
 N.B. Les poids et les dimensions indiqués ci-dessus sont donnés à titre indicatif.
 N.B. Указанные вес и размеры, являются ориентировочными.

© La riproduzione
 anche parziale
 del presente catalogo
 è vietata.

COLTELLI E LAME PER TRINCIA E DECESPUGLIATORI
Knives and blades for choppers and flail-mowers
Hammerschlägel und Schlägelmesser
Couteaux et lames pour hacheuses et debroussailleuses
Ножи и лезвия для мульчирователей и косилок



Marca della macchina Machine brand name Marke der Maschine Marque de la machine Марка машины	Codice Nr. Ref. Nr. Re. Nr. Ref. Nr. Код №		Quote Dimensions Abmessungen Dimensions Размеры mm	Curvatura Curvature Krümmung Courbure Изгиб	Piatto Plate Platte Plaque Профиль mm	Fori Holes Löcher Trous Отверстия Ø mm	Interasse Center distance Achsenabstand Entraxe Расстояние Ø - Ø	Peso Weight Gewicht Poids Вес gr
MOREAU								
BT 298	265003		A = 235 B = 55	—	60x8	30	—	840
MORNEAU								
602192430	272001		A = 98 B = 47	—	45x5	19x14	—	180
MOTT								
Flail	269003		A = 100 B = 45	—	45x6	14x32	—	260
Flail	269004		A = 84 B = 36	—	40x5	13x27	—	110
	269006		A = 113 B = 44	—	45x4	14x26	—	150
MURATORI								
Coltello universale MTZ 100 - 130 - 160 12010200	268032		A = 115 B = 44	—	35x5	14,5	—	150
Coltello MT8 - MT 12 - 13 - 14	268033		A = 115 B = 50	—	40x8	20,5	—	300
Spatola	357003		A = 79 B = 70	—	70x3	14x25	—	150
NICOLAS								
Gyro	278001		A = 155 B = 45	C	75x7	12,5	34	600

COLTELLI E LAME PER TRINCIA E DECESPUGLIATORI
Knives and blades for choppers and flail-mowers
Hammerschlägel und Schlägelmesser
Couteaux et lames pour hacheuses et debroussailleuses
Ножи и лезвия для мульчирователей и косилок



Marca della macchina Machine brand name Marke der Maschine Marque de la machine Марка машины	Codice Nr. Ref. Nr. Re. Nr. Ref. Nr. Код №		Quote Dimensions Abmessungen Dimensions Размеры mm	Curvatura Curvature Krümmung Courbure Изгиб	Piatto Plate Platte Plaque Профиль mm	Fori Holes Löcher Trous Отверстия Ø mm	Interasse Center distance Achsenabstand Entraxe Расстояние Ø - Ø	Peso Weight Gewicht Poids Вес gr
Bride	278002		A = 115 B = 30	—	30x8	12,5	34	380
Boccola Ø 28x30	278003		A = 28 B = 30 C = 20,5	—	Ø 28	20,5	—	60
Paletta ventilante	278004		A = 203 B = 87	—	60x10	28,5	—	1330

NOBILI								
Lama Triturator RM	279001		A = 247 B = 66	—	60x8	25,5	—	960
Universale BMT B10 - B12	279002		A = 178 B = 60	—	40x8	16,5	—	470
Lama diritta BMG 02 17156	279003		A = 205	—	60x10	25,5	—	900
Coltello a Y BMG 01 17283-2555004	279004		A = 205 B = 52	—	60x10	25,5	—	930
Coltello a L BMG lama a squadro 05 17157-255001	279005		A = 205 B = 47	SQ	60x10	25,5	—	1080
BNE 19813-1781000	279007		A = 126 B = 35	—	40x8	16,5	—	350
	279012		A = 120 B = 43	—	40x8	16,5	—	300
21978-1891018	279020		A = 134 B = 49	—	45x8	16,5	—	400
Portacoltello	279022		A = 49 B = 25	—	70x10	25,5	—	560
Paletta ventilante 23868-1551147	279023		A = 183 B = 52	—	34x8	26	—	520

Tutti i modelli sono di nostra produzione e non originali.
 All models are of our manufacture and are not original.
 Alle unsere Landwirtschaftliche erzeugnisse sind unsere produktion und sind nicht original.
 Tous les modèles sont notre production et ne sont pas des produits d'origine.
 Все модели нашего производства и не являются оригинальными.

N.B. Pesi e misure sopra descritti sono puramente indicativi.
 N.B. The above weights and dimensions are given for reference only.
 N.B. Die obengenannten Gewichte und Abmessungen sind richtungsweisend.
 N.B. Les poids et les dimensions indiqués ci-dessus sont donnés à titre indicatif.
 N.B. Указанные вес и размеры, являются ориентировочными.

© La riproduzione
 anche parziale
 del presente catalogo
 è vietata.

COLTELLI E LAME PER TRINCIA E DECESPUGLIATORI
Knives and blades for choppers and flail-mowers
Hammerschlägel und Schlägelmesser
Couteaux et lames pour hacheuses et debroussailleuses
Ножи и лезвия для мульчирователей и косилок



Marca della macchina Machine brand name Marke der Maschine Marque de la machine Марка машины	Codice Nr. Ref. Nr. Re. Nr. Ref. Nr. Код №		Quote Dimensions Abmessungen Dimensions Размеры mm	Curvatura Curvature Krümmung Courbure Изгиб	Piatto Plate Platte Plaque Профиль mm	Fori Holes Löcher Trous Отверстия Ø mm	Interasse Center distance Achsenabstand Entraxe Расстояние Ø - Ø	Peso Weight Gewicht Poids Вес gr
Paletta ventilante 04 24956-1921002	279024		A = 115 B = 42	—	100×6	17	—	490
Trincia diritto	279032		A = 135	—	40×8	16,5	—	310
Controcoltello stampato	279035		A = 186 B = 30	—	—	—	—	600

OMARV

Paletta ventilante	285005		A = 190 B = 52	—	100×8	28	—	1470
Coltello a Y	285006		A = 205 B = 52	—	60×10	25,5	—	930
Paletta ventilante	285010		A = 140 B = 47	—	80×8	12,5	—	680
Trincia SQ	285013		A = 205 B = 52	SQ	60×10	25,5	—	1080
Trincia Y	285014		A = 110 B = 55	—	50×10	25,5	—	500
Coltello rotore	285019		A = 127 B = 64	—	50×10	25,5	—	550

OREC

Trincia Y	Orec/01		A = 100 B = 30	—	30×4	10,5	—	100
------------------	---------	--	-------------------	---	------	------	---	-----

ORSI

Cavallotto bombato Orsi	151010		A = 79 B = 49	—	Ø 13	14,5	—	240
--------------------------------	--------	--	------------------	---	------	------	---	-----

COLTELLI E LAME PER TRINCIA E DECESPUGLIATORI
Knives and blades for choppers and flail-mowers
Hammerschlägel und Schlägelmesser
Couteaux et lames pour hacheuses et debroussailleuses
Ножи и лезвия для мульчирователей и косилок



Marca della macchina Machine brand name Marke der Maschine Marque de la machine Марка машины	Codice Nr. Ref. Nr. Re. Nr. Ref. Nr. Код №		Quote Dimensions Abmessungen Dimensions Размеры mm	Curvatura Curvature Krümmung Courbure Изгиб	Piatto Plate Platte Plaque Профиль mm	Fori Holes Löcher Trous Отверстия Ø mm	Interasse Center distance Achsenabstand Entraxe Расстояние Ø - Ø	Peso Weight Gewicht Poids Вес gr
Cavallotto	151032		A = 71,5 B = 49	—	Ø 13	14,5	—	190
Trincia Y 23002	295001		A = 135 B = 63	—	60x8	16,5	—	570
½ giro 23044	295002		A = 150 B = 52	—	50x10	25,5	—	500
Trincia Y 23041	295003		A = 92 B = 40	—	40x8	35x16	—	200
Trincia Y 23043	295004		A = 150 B = 40	—	60x8	25,5	—	510
Trincia Y 23042	295005		A = 148 B = 40	—	40x8	20,5	—	350
Trincia Y 23001	295008		A = 107 B = 42	—	40x8	30x14	—	250

OSMA

Trincia Y	293003		A = 155 B = 57	—	50x8	20,5	—	480
Trincia Y	293016		A = 115 B = 41	—	45x8	30x14	—	300
Coltello barca	293018		A = 156 B = 73	—	60x8	12,5	38	600
Trincia Y	293020		A = 152 B = 55	—	60x8	20,5	—	570

PALLADINO

Lungo 560109	298006		A = 105 B = 40	—	40x10	16,5	—	300
-------------------------	--------	--	-------------------	---	-------	------	---	-----

Tutti i modelli sono di nostra produzione e non originali.
 All models are of our manufacture and are not original.
 Alle unsere Landwirtschaftliche erzeugnisse sind unsere produktion und sind nicht original.
 Tous les modèles sont notre production et ne sont pas des produits d'origine.
 Все модели нашего производства и не являются оригинальными.

N.B. Pesi e misure sopra descritti sono puramente indicativi.
 N.B. The above weights and dimensions are given for reference only.
 N.B. Die obengenannten Gewichte und Abmessungen sind richtungsweisend.
 N.B. Les poids et les dimensions indiqués ci-dessus sont donnés à titre indicatif.
 N.B. Указанные вес и размеры, являются ориентировочными.

© La riproduzione
 anche parziale
 del presente catalogo
 è vietata.

COLTELLI E LAME PER TRINCIA E DECESPUGLIATORI

Knives and blades for choppers and flail-mowers

Hammerschlägel und Schlägelmesser

Couteaux et lames pour hacheuses et debroussailleuses

Ножи и лезвия для мульчирователей и косилок



Marca della macchina Machine brand name Marke der Maschine Marque de la machine Марка машины	Codice Nr. Ref. Nr. Re. Nr. Ref. Nr. Код №		Quote Dimensions Abmessungen Dimensions Размеры mm	Curvatura Curvature Krümmung Courbure Изгиб	Piatto Plate Platte Plaque Профиль mm	Fori Holes Löcher Trous Отверстия Ø mm	Interasse Center distance Achsenabstand Entraxe Расстояние Ø - Ø	Peso Weight Gewicht Poids Вес gr
Corto 560110	298007		A = 105 B = 29	—	40×10	16,5	—	280
Trincia Y 560111	298011		A = 205 B = 52	—	60×8	25,5	—	740
Trincia Y 560114	298015		A = 100 B = 40	—	40×5	12,5	—	150
Trincia SQ 560151	298016		A = 106 B = 75	SQ	50×10	16,5	—	580
Paletta ventilante 560113	298019		A = 176 B = 66	—	100×8	26	—	1500
Coltello ½ giro 560132	298021		A = 195 B = 18	—	50×8	25,5	—	580
Spatola 560136	298026		A = 82 B = 70	—	70×3	14×25	—	150

PERUGINI CONCEPT

Coltello Y	304006		A = 205 B = 52	—	60×10	25,5	—	930
Paletta ventilante	304007		A = 183 B = 52	—	34×8	26	—	550
Spatola	357010		A = 79 B = 70	—	70×3	12,5	—	160

PERUZZO

Trincia Y	306001		A = 95 B = 30	—	30×4	27×13	—	90
Trincia Y	336002		A = 83 B = 40	—	40×5	13×26	—	120

COLTELLI E LAME PER TRINCIA E DECESPUGLIATORI
Knives and blades for choppers and flail-mowers
Hammerschlägel und Schlägelmesser
Couteaux et lames pour hacheuses et debroussailleuses
Ножи и лезвия для мульчирователей и косилок



Marca della macchina Machine brand name Marke der Maschine Marque de la machine Марка машины	Codice Nr. Ref. Nr. Re. Nr. Ref. Nr. Код №		Quote Dimensions Abmessungen Dimensions Размеры mm	Curvatura Curvature Krümmung Courbure Изгиб	Piatto Plate Platte Plaque Профиль mm	Fori Holes Löcher Trous Отверстия Ø mm	Interasse Center distance Achsenabstand Entraxe Расстояние Ø - Ø	Peso Weight Gewicht Poids Вес gr
Trincia Y	306004		A = 98 B = 30	—	30x5	13x26	—	130
PROCOMAS								
	307002		A = 140 B = 60	—	60x6	25,5	—	380
	307003		A = 125 B = 48	—	40x6	16,5	—	230
Boccola	307004		A = 25 B = 13 C = 17	—	—	16,5	—	30
ROUSSEAU								
Cavallotto girato 5.556.03	151001		A = 63 B = 48	—	Ø 11	11,5	—	150
Vite 7/16x84 5.952.24	322002			—	—	—	—	70
Dado autobloccante	336006			—	—	—	—	10
5.254.22	322004		A = 100 B = 41	—	40x5	14x26	—	150
Distanziale 5.200.05	322005		A = 20 B = 26 C = 12	—	—	12	—	30
Universale 5.254.30	322008		A = 98 B = 34	—	35x8	14x30	—	200
Cavallotto 5.556.01	336004		A = 63 B = 48	—	Ø 11	11,5	—	130

Tutti i modelli sono di nostra produzione e non originali.
 All models are of our manufacture and are not original.
 Alle unsere Landwirtschaftliche erzeugnisse sind unsere produktion und sind nicht original.
 Tous les modèles sont notre production et ne sont pas des produits d'origine.
 Все модели нашего производства и не являются оригинальными.

N.B. Pesi e misure sopra descritti sono puramente indicativi.
 N.B. The above weights and dimensions are given for reference only.
 N.B. Die obengenannten Gewichte und Abmessungen sind richtungsweisend.
 N.B. Les poids et les dimensions indiqués ci-dessus sont donnés à titre indicatif.
 N.B. Указанные вес и размеры, являются ориентировочными.



© La riproduzione
 anche parziale
 del presente catalogo
 è vietata.

COLTELLI E LAME PER TRINCIA E DECESPUGLIATORI
Knives and blades for choppers and flail-mowers
Hammerschlägel und Schlägelmesser
Couteaux et lames pour hacheuses et debroussailleuses
Ножи и лезвия для мульчирователей и косилок

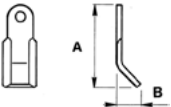

Marca della macchina Machine brand name Marke der Maschine Marque de la machine Марка машины	Codice Nr. Ref. Nr. Re. Nr. Ref. Nr. Код №	Quote Dimensions Abmessungen Dimensions Размеры mm	Curvatura Curvature Krümmung Courbure Изгиб	Piatto Plate Platte Plaque Профиль mm	Fori Holes Löcher Trous Отверстия Ø mm	Interasse Center distance Achsenabstand Entraxe Расстояние Ø - Ø	Peso Weight Gewicht Poids Вес gr
--	--	---	---	--	---	---	---

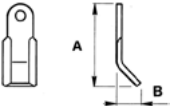
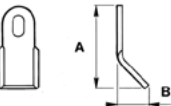
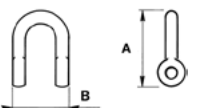
SEKO								
Trincia Y	330001		A = 215 B = 55	—	60x7	25	—	680

SICMA S.R.L.								
Trinciastocchi a Y	333003		A = 200 B = 52	—	60x8	25,5	—	720
Decespugliatore FM-FR 900240060	333016		A = 90 B = 40	—	40x6	30x14	—	210
Cavalotto	333023		A = 63 B = 48	—	Ø 11	12,5	—	105
Coltello spatola	333026		A = 82 B = 70	—	70x3	14x25	—	160

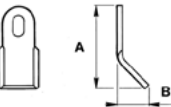
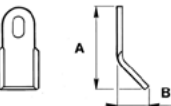
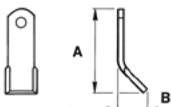
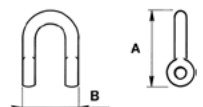
S.M.A.								
BG59	336001		A = 100 B = 41	—	40x5	14x26	—	150
BGC corto	336002		A = 83 B = 40	—	40x5	13x26	—	120
LAU	336003		A = 134 B = 40	—	40x5	14,5	—	200
Cavalotto	336004		A = 63 B = 48	—	Ø 11	11,5	—	130
Vite 7/16x80 10,9 filetto 15 mm	336005			—	—	—	—	70
Dado autobloccante	336006			—	—	—	—	10

COLTELLI E LAME PER TRINCIA E DECESPUGLIATORI
Knives and blades for choppers and flail-mowers
Hammerschlägel und Schlägelmesser
Couteaux et lames pour hacheuses et debroussailleuses
Ножи и лезвия для мульчирователей и косилок



Marca della macchina Machine brand name Marke der Maschine Marque de la machine Марка машины	Codice Nr. Ref. Nr. Re. Nr. Ref. Nr. Код №		Quote Dimensions Abmessungen Dimensions Размеры mm	Curvatura Curvature Krümmung Courbure Изгиб	Piatto Plate Platte Plaque Профиль mm	Fori Holes Löcher Trous Отверстия Ø mm	Interasse Center distance Achsenabstand Entraxe Расстояние Ø - Ø	Peso Weight Gewicht Poids Вес gr
T 59 stampato	336007		A = 97 B = 33	—	40x8	14x26	—	180
Cavallotto girato	336015		A = 63 B = 48	—	Ø 11	11,5	—	150
Coltello forgiato	336016		A = 98 B = 34	—	35x8	14x30	—	200
Distanziale	336018		A = 20 B = 26 C = 12,5	—	—	12,5	—	40
Trincia diritto	336020		A = 80	—	40x5	14x30	—	100

TAARUP								
Patent 40.882.300	346002		A = 145 B = 48	—	75x7	14	—	560
50-507-000	346003		A = 215 B = 48	—	65x6,5	29,5	—	680
Bride 40.880.000	346004		A = 103	—	35x8	14,5	—	420
Boccola Ø 28x40 40.881.100 per 346003	346005		A = 28 B = 40 C = 20,5	—	—	20,5	—	80
Distanziale	346008		A = 35 B = 13 C = 29	—	—	29	—	35
Trincia S	346014		A = 215 B = 68	—	60x10	22,5	—	1000

TIERRE								
Coltello Y	347004		A = 215 B = 50	—	60x7	25,5	—	700

Tutti i modelli sono di nostra produzione e non originali.
 All models are of our manufacture and are not original.
 Alle unsere Landwirtschaftliche erzeugnisse sind unsere produktion und sind nicht original.
 Tous les modèles sont notre production et ne sont pas des produits d'origine.
 Все модели нашего производства и не являются оригинальными.

N.B. Pesi e misure sopra descritti sono puramente indicativi.
 N.B. The above weights and dimensions are given for reference only.
 N.B. Die obengenannten Gewichte und Abmessungen sind richtungsweisend.
 N.B. Les poids et les dimensions indiqués ci-dessus sont donnés à titre indicatif.
 N.B. Указанные вес и размеры, являются ориентировочными.

© La riproduzione
 anche parziale
 del presente catalogo
 è vietata.

COLTELLI E LAME PER TRINCIA E DECESPUGLIATORI

Knives and blades for choppers and flail-mowers

Hammerschlägel und Schlägelmesser

Couteaux et lames pour hacheuses et debroussailleuses

Ножи и лезвия для мульчирователей и косилок



Marca della macchina Machine brand name Marke der Maschine Marque de la machine Марка машины	Codice Nr. Ref. Nr. Re. Nr. Ref. Nr. Код №		Quote Dimensions Abmessungen Dimensions Размеры mm	Curvatura Curvature Krümmung Courbure Изгиб	Piatto Plate Platte Plaque Профиль mm	Fori Holes Löcher Trous Отверстия Ø mm	Interasse Center distance Achsenabstand Entraxe Расстояние Ø - Ø	Peso Weight Gewicht Poids Вес gr
Trincia Y	347012		A = 136 B = 42	—	40x10	16,5	—	410
Spatola 52002011	357004		A = 82 B = 72	—	70x3	10,5	—	160

TRINCIA VARI								
TG714	04		A = 114 B = 41	—	40x5	33x14	—	170
MT512	05		A = 89 B = 35	—	40x6,5	31x16	—	175
Trincia stampato	07		A = 100 B = 40	—	45x8	16x38	—	310

TURNER								
	353001		A = 98 B = 34	—	30x10	12,5x32,5	—	200
	353002		A = 98 B = 34	—	35x10	12,5x32,5	—	230

VIGOLO								
Paletta ventilante 93199001	360006		A = 130 B = 43	—	40x8	28	—	500
Trincia TSA-L 931040002	360009		A = 120 B = 70	—	60x8	25,5	—	460
Trincia TST 931040001	360010		A = 200 B = 80	—	60x8	25,5	—	700

COLTELLI E LAME PER TRINCIA E DECESPUGLIATORI
Knives and blades for choppers and flail-mowers
Hammerschlägel und Schlägelmesser
Couteaux et lames pour hacheuses et debroussailleuses
Ножи и лезвия для мульчирователей и косилок

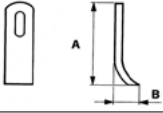

Marca della macchina Machine brand name Marke der Maschine Marque de la machine Марка машины	Codice Nr. Ref. Nr. Re. Nr. Ref. Nr. Код №		Quote Dimensions Abmessungen Dimensions Размеры mm	Curvatura Curvature Krümmung Courbure Изгиб	Piatto Plate Platte Plaque Профиль mm	Fori Holes Löcher Trous Отверстия Ø mm	Interasse Center distance Achsenabstand Entraxe Расстояние Ø - Ø	Peso Weight Gewicht Poids Вес gr
--	--	--	---	---	--	---	---	---

VOTEX								
	359001		A = 98 B = 34	—	35x10	13x33	—	230

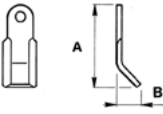
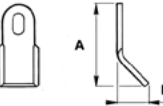
ZANON								
Coltello Y 5350040	361001		A = 119 B = 52	—	40x8	20,5	—	290
	361002		A = 81 B = 43	—	40x8	14x29	—	250

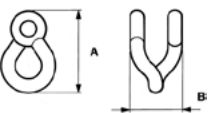
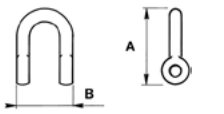
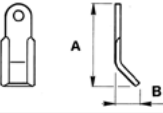
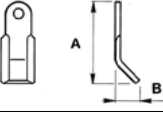
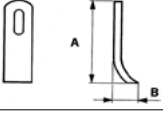
ZAPPATOR								
Cavallotto girato 61000421	151001		A = 63 B = 48	—	Ø 11	11,5	—	150
Cavallotto U 40400415	336004		A = 63 B = 48	—	Ø 11	11,5	—	130
Trincia universale 50000421	372002		A = 155 B = 58	—	60x10	20,5	—	780
Trincia universale corto 56000421	372008		A = 120 B = 65	—	60x10	20,5	—	700
61000422	372014		A = 85 B = 27	—	50x8	14x35	—	250

Tutti i modelli sono di nostra produzione e non originali.
 All models are of our manufacture and are not original.
 Alle unsere Landwirtschaftliche erzeugnisse sind unsere produktion und sind nicht original.
 Tous les modèles sont notre production et ne sont pas des produits d'origine.
 Все модели нашего производства и не являются оригинальными.

N.B. Pesi e misure sopra descritti sono puramente indicativi.
 N.B. The above weights and dimensions are given for reference only.
 N.B. Die obengenannten Gewichte und Abmessungen sind richtungsweisend.
 N.B. Les poids et les dimensions indiqués ci-dessus sont donnés à titre indicatif.
 N.B. Указанные вес и размеры, являются ориентировочными.

© La riproduzione
 anche parziale
 del presente catalogo
 è vietata.



A stylized globe showing the outlines of continents. A banner is draped across the middle of the globe, containing the word "eurozappa" in a bold, lowercase, sans-serif font.

eurozappa

MAZZE PER TRINCIASARMENTI

Hammer

Hammerschlegel

Marteaux pour broyeurs

Молотковые ножи для мульчирования





MAZZE PER TRINCIASARMENTI
Hammer
Hammerschlegel
Marteaux pour broyeurs
Молотковые ножи для мульчирования

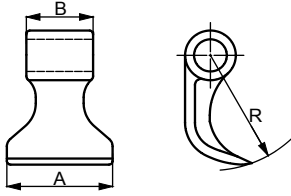
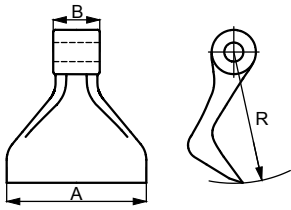
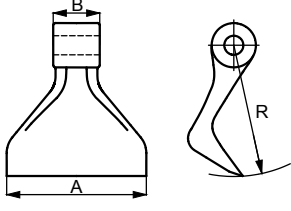
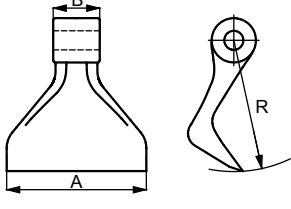
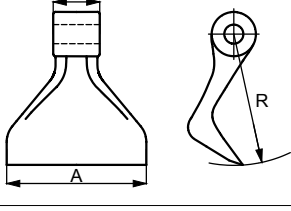
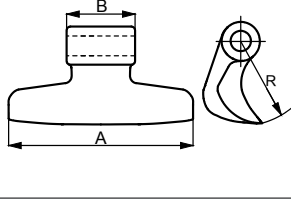
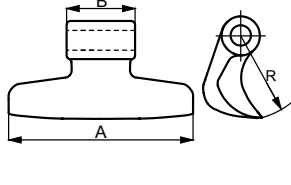

Marca della macchina Machine brand name Marke der Maschine Marque de la machine Марка машины	Codice Nr. Ref. Nr. Re. Nr. Ref. Nr. Код №		Quote Dimensions Abmessungen Dimensions Размеры mm	Piatto Plate Platte Plaque Профиль mm	Fori Holes Löcher Trous Отверстия Ø mm	Peso Weight Gewicht Poids Вес gr	Passo Pitch Winde Pas Шаг mm
Peruzzo	Mazza 03/26		A = 86 B = 52 R = 95	—	26,5	930	—
Acma Agricom Becchio Omarv Seppi Sicma srl Ubaldi	Mazza 04/16		A = 120 B = 40 R = 110	—	16,5	1450	—
Agram Alpego Maschio Meaat Omarv	Mazza 04/18		A = 120 B = 40 R = 110	—	18,5	1435	—
Becchio	Mazza 04/19		A = 120 B = 40 R = 110	—	19,5	1425	—
Ubaldi Zilli	Mazza 04/20		A = 120 B = 40 R = 110	—	20,5	1415	—
Aedes Agricom	Mazza 05/16		A = 185 B = 70 R = 85	—	16,5	2130	—
Aedes Agricom Nuova Cabe	Mazza 05/20		A = 185 B = 70 R = 85	—	20,5	2100	—

Tutti i modelli sono di nostra produzione e non originali.
 All models are of our manufacture and are not original.
 Alle unsere Landwirtschaftliche erzeugnisse sind unsere produktion und sind nicht original.
 Tous les modèles sont notre production et ne sont pas des produits d'origine.
 Все модели нашего производства и не являются оригинальными.

N.B. Pesi e misure sopra descritti sono puramente indicativi.
 N.B. The above weights and dimensions are given for reference only.
 N.B. Die obengenannten Gewichte und Abmessungen sind richtungsweisend.
 N.B. Les poids et les dimensions indiqués ci-dessus sont donnés à titre indicatif.
 N.B. Указанные вес и размеры, являются ориентировочными.

© La riproduzione
 anche parziale
 del presente catalogo
 è vietata.

MAZZE PER TRINCIASARMENTI

Hammer

Hammerschlegel

Marteaux pour broyeurs

Молотковые ножи для мульчирования

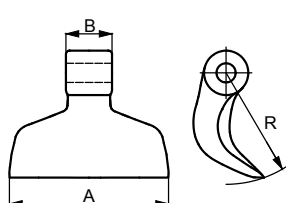
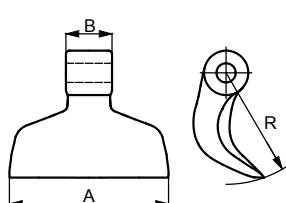
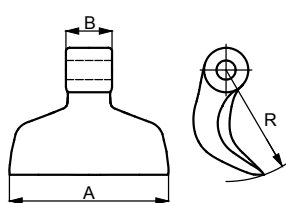
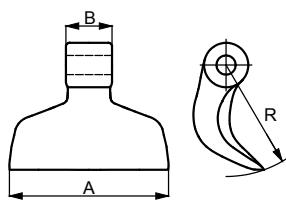
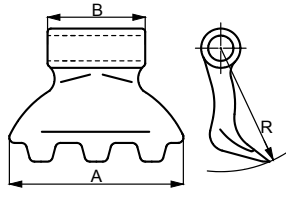
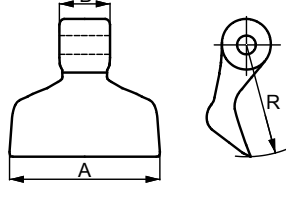
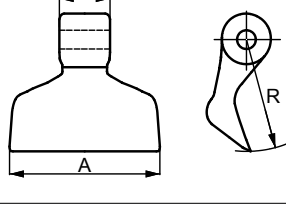
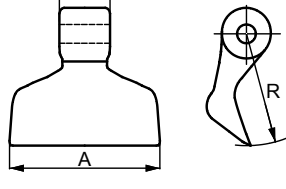

Marca della macchina Machine brand name Marke der Maschine Marque de la machine Марка машины	Codice Nr. Ref. Nr. Re. Nr. Ref. Nr. Код №		Quote Dimensions Abmessungen Dimensions Размеры mm	Piatto Plate Platte Plaque Профиль mm	Fori Holes Löcher Trous Отверстия Ø mm	Peso Weight Gewicht Poids Вес gr	Passo Pitch Winde Pas Шаг mm
Berti Maschio Meaat Vigolo Celli	Mazza 06/16		A = 137 B = 40 R = 95	—	16,5	1600	—
Alpego Meaat Omarv	Mazza 06/18		A = 137 B = 40 R = 95	—	18,5	1600	—
Forigo Ubaldi	Mazza 06/20		A = 137 B = 40 R = 95	—	20,5	1600	—
Willibald	Mazza 07/20		A = 155 B = 89 R = 110	—	20,5	1750	—
Zanon	Mazza 08/14		A = 120 B = 40 R = 90	—	14,5	1080	—
Agricom Becchio Howard Seppi	Mazza 08/16		A = 120 B = 40 R = 90	—	16,5	1080	—
Becchio	Mazza 08/19		A = 120 B = 40 R = 90	—	19,5	1080	—

MAZZE PER TRINCIASARMENTI
Hammer
Hammerschlegel
Marteaux pour broyeurs
Молотковые ножи для мульчирования

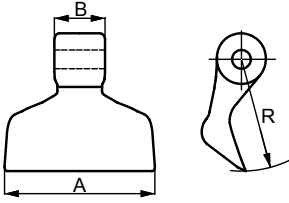
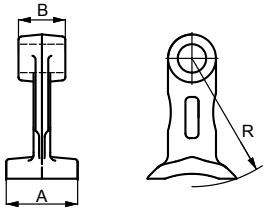
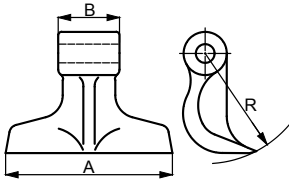
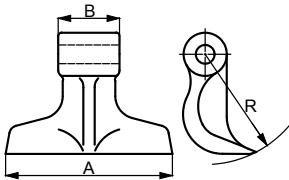
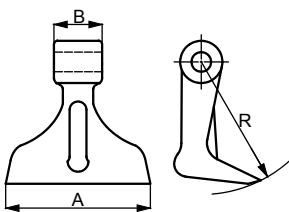
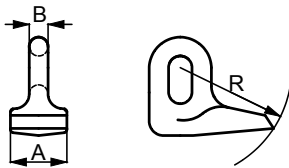
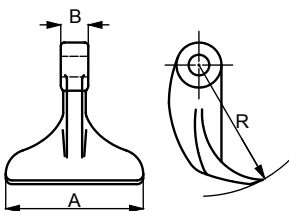

Marca della macchina Machine brand name Marke der Maschine Marque de la machine Марка машины	Codice Nr. Ref. Nr. Re. Nr. Ref. Nr. Код №		Quote Dimensions Abmessungen Dimensions Размеры mm	Piatto Plate Platte Plaque Профиль mm	Fori Holes Löcher Trous Отверстия Ø mm	Peso Weight Gewicht Poids Вес gr	Passo Pitch Winde Pas Шаг mm
Agricom Forigo Nuova Cabe Seppi Zappator	Mazza 08/20		A = 120 B = 40 R = 90	—	20,5	1080	—
Ferri bidirezionale Marolin	Mazza 09/25		A = 64 B = 43 R = 115	—	25,5	1000	—
Falconero Sicma S.R.L. Sovema	Mazza 10/16		A = 147 B = 54 R = 97	—	16,5	1800	—
Agrimaster Concept Perugini Falconero Muratori Orsi Sicma S.R.L.	Mazza 10/20		A = 147 B = 54 R = 97	—	20,5	1740	—
Concept Perugini Kverneland Maschio Sicma S.R.L.	Mazza 12/16		A = 120 B = 40 R = 110	—	16,5	1280	—
Bomford Bruni	Mazza 13		A = 39 B = 13 R = 75	—	32x16	400	—
Omarv Bellon	Mazza 14/16		A = 112 B = 22 R = 105	—	16,5	960	—

Tutti i modelli sono di nostra produzione e non originali.
 All models are of our manufacture and are not original.
 Alle unsere Landwirtschaftliche erzeugnisse sind unsere produktion und sind nicht original.
 Tous les modèles sont notre production et ne sont pas des produits d'origine.
 Все модели нашего производства и не являются оригинальными.

N.B. Pesi e misure sopra descritti sono puramente indicativi.
 N.B. The above weights and dimensions are given for reference only.
 N.B. Die obengenannten Gewichte und Abmessungen sind richtungsweisend.
 N.B. Les poids et les dimensions indiqués ci-dessus sont donnés à titre indicatif.
 N.B. Указанные вес и размеры, являются ориентировочными.

© La riproduzione
 anche parziale
 del presente catalogo
 è vietata.

MAZZE PER TRINCIASARMENTI
Hammer
Hammerschlegel
Marteaux pour broyeurs
Молотковые ножи для мульчирования



Marca della macchina Machine brand name Marke der Maschine Marque de la machine Марка машины	Codice Nr. Ref. Nr. Re. Nr. Ref. Nr. Код №		Quote Dimensions Abmessungen Dimensions Размеры mm	Piatto Plate Platte Plaque Профиль mm	Fori Holes Löcher Trous Отверстия Ø mm	Peso Weight Gewicht Poids Вес gr	Passo Pitch Winde Pas Шаг mm
Agrimaster	Mazza 15/25		A = 120 B = 30 R = 126	—	25,5	950	—
Ferri	Mazza 16/16		A = 104 B = 42 R = 119	—	16,5	1350	—
Ferri	Mazza 16/20		A = 104 B = 42 R = 119	—	20,5	1300	—
Ferri 0901016 Sicma S.R.L.	Mazza 18/16		A = 180 B = 70 R = 100	—	16,5	2340	—
Tortella	Mazza 20/22		A = 166 B = 98 R = 116	—	22,5	2110	—
Maschio	Mazza 22/16		A = 130 B = 40 R = 110	—	16,5	1090	—
Meat Perfect Rosatello	Mazza 23/20		A = 196 B = 76 R = 109	—	20,5	2050	—

MAZZE PER TRINCIASARMENTI
Hammer
Hammerschlegel
Marteaux pour broyeurs
Молотковые ножи для мульчирования

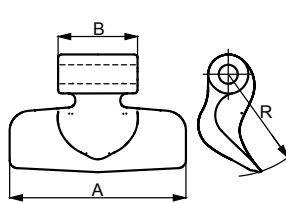
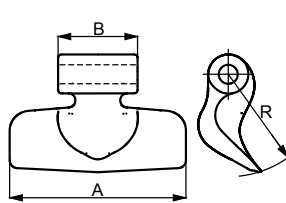
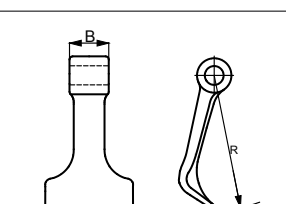
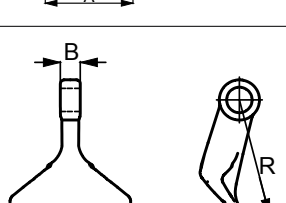
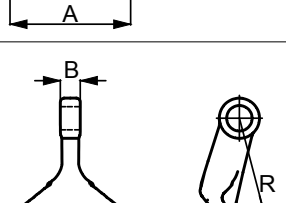
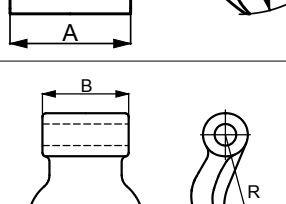
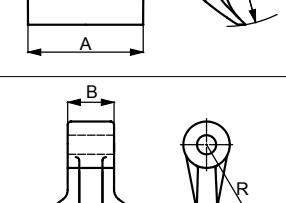
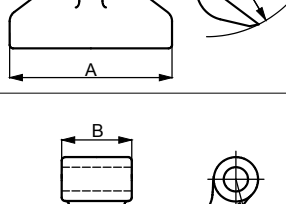

Marca della macchina Machine brand name Marke der Maschine Marque de la machine Марка машины	Codice Nr. Ref. Nr. Re. Nr. Ref. Nr. Код №		Quote Dimensions Abmessungen Dimensions Размеры mm	Piatto Plate Platte Plaque Профиль mm	Fori Holes Löcher Trous Отверстия Ø mm	Peso Weight Gewicht Poids Вес gr	Passo Pitch Winde Pas Шаг mm
Celli Palladino	Mazza 25/16		A = 153 B = 70 R = 90	—	16,5	1760	—
Celli Kuhn Nobili	Mazza 26/25		A = 115 B = 51,5 R = 175	—	25,5	1700	—
Maschio Furba M48400405	Mazza 27/14		A = 78 B = 13 R = 75	—	14,5	250	—
Dragone leggera	Mazza 27/16		A = 78 B = 13 R = 75	—	16,5	250	—
Dragone pesante	Mazza 28/18		A = 99 B = 74 R = 100	—	18,5	1500	—
Meat Zilli Berti leggera	Mazza 30/16		A = 140 B = 40 R = 100	—	16,5	1220	—
Maschio Bisonte M03400410 Humus	Mazza 31/20		A = 150 B = 60 R = 90	—	20,5	1250	—

Tutti i modelli sono di nostra produzione e non originali.
 All models are of our manufacture and are not original.
 Alle unsere Landwirtschaftliche erzeugnisse sind unsere produktion und sind nicht original.
 Tous les modèles sont notre production et ne sont pas des produits d'origine.
 Все модели нашего производства и не являются оригинальными.

N.B. Pesi e misure sopra descritti sono puramente indicativi.
 N.B. The above weights and dimensions are given for reference only.
 N.B. Die obengenannten Gewichte und Abmessungen sind richtungsweisend.
 N.B. Les poids et les dimensions indiqués ci-dessus sont donnés à titre indicatif.
 N.B. Указанные вес и размеры, являются ориентировочными.

© La riproduzione anche parziale del presente catalogo è vietata.

MAZZE PER TRINCIASARMENTI

Hammer

Hammerschlegel

Marteaux pour broyeurs

Молотковые ножи для мульчирования

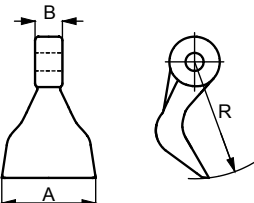
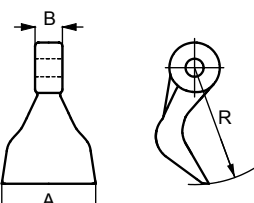
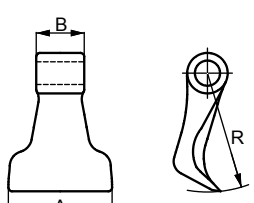
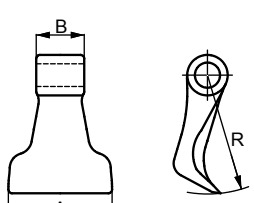
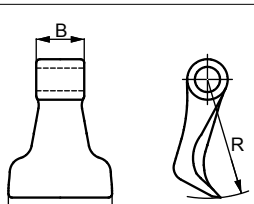
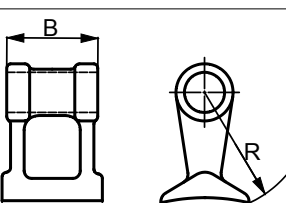
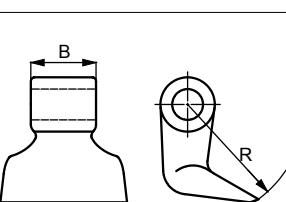

Marca della macchina Machine brand name Marke der Maschine Marque de la machine Марка машины	Codice Nr. Ref. Nr. Re. Nr. Ref. Nr. Код №		Quote Dimensions Abmessungen Dimensions Размеры mm	Piatto Plate Platte Plaque Профиль mm	Fori Holes Löcher Trous Отверстия Ø mm	Peso Weight Gewicht Poids Вес gr	Passo Pitch Winde Pas Шаг mm
Ubaldi	Mazza 32/14		A = 75,5 B = 22 R = 95	—	14,5	720	—
Meaat	Mazza 32/16		A = 75,5 B = 22 R = 95	—	16,5	700	—
Acma Agrimaster Falconero Orsi Zanon	Mazza 37/14		A = 85 B = 40 R = 100	—	14,5	750	—
Acma Agrimaster Concept Perugini Maschio Omarv Sicma S.R.L. Tierre Ubaldi	Mazza 37/16		A = 85 B = 40 R = 100	—	16,5	740	—
Agrimaster Bruni	Mazza 37/20		A = 85 B = 40 R = 100	—	20,5	720	—
Rousseau	Mazza 38/25		A = 65 B = 58 R = 70	—	25,5	465	—
Falc	Mazza 40/25		A = 105 B = 54 R = 98	—	25,5	1450	—

MAZZE PER TRINCIASARMENTI
Hammer
Hammerschlegel
Marteaux pour broyeur
Молотковые ножи для мульчирования

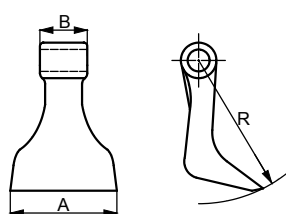
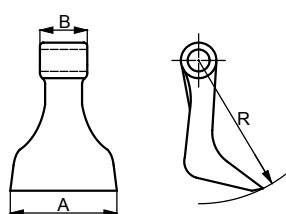
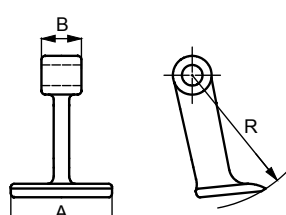
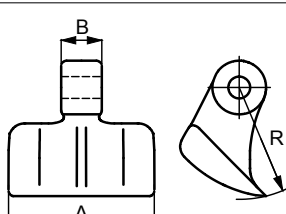
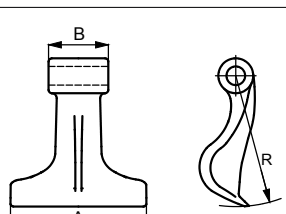
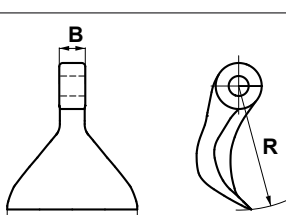
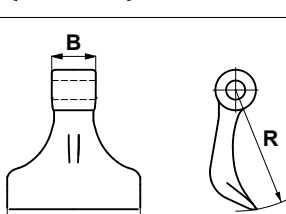
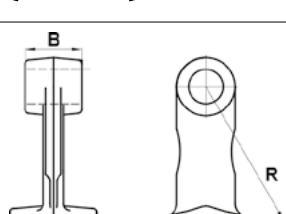

Marca della macchina Machine brand name Marke der Maschine Marque de la machine Марка машины	Codice Nr. Ref. Nr. Re. Nr. Ref. Nr. Код №		Quote Dimensions Abmessungen Dimensions Размеры mm	Piatto Plate Platte Plaque Профиль mm	Fori Holes Löcher Trous Отверстия Ø mm	Peso Weight Gewicht Poids Вес gr	Passo Pitch Winde Pas Шаг mm
Lagarde	Mazza 46/18		A = 90 B = 40 R = 121	—	18,5	1440	—
Lagarde	Mazza 47/16		A = 81 B = 32 R = 108	—	16,5	580	—
Meritano	Mazza 48/16		A = 110 B = 30 R = 85	—	16,5	1600	—
Agricom Facma	Mazza 49/22		A = 165 B = 73 R = 158	—	22,5	2800	—
Bellon Frontoni Perfect	Mazza 50/16		A = 110 B = 22 R = 100	—	16,5	750	—
Kuhn	Mazza 51/16		A = 115 B = 38 R = 105	—	16,5	850	—
Orsi	Mazza 57/25		A = 60 B = 38 R = 135	—	25,5	890	—

Tutti i modelli sono di nostra produzione e non originali.
 All models are of our manufacture and are not original.
 Alle unsere Landwirtschaftliche erzeugnisse sind unsere produktion und sind nicht original.
 Tous les modèles sont notre production et ne sont pas des produits d'origine.
 Все модели нашего производства и не являются оригинальными.

N.B. Pesi e misure sopra descritti sono puramente indicativi.
 N.B. The above weights and dimensions are given for reference only.
 N.B. Die obengenannten Gewichte und Abmessungen sind richtungsweisend.
 N.B. Les poids et les dimensions indiqués ci-dessus sont donnés à titre indicatif.
 N.B. Указанные вес и размеры, являются ориентировочными.

© La riproduzione
 anche parziale
 del presente catalogo
 è vietata.

MAZZE PER TRINCIASARMENTI

Hammer

Hammerschlegel

Marteaux pour broyeurs

Молотковые ножи для мульчирования

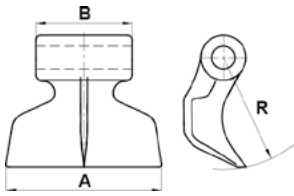
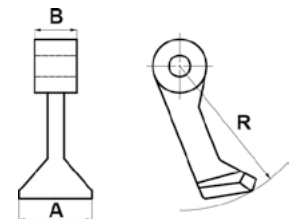
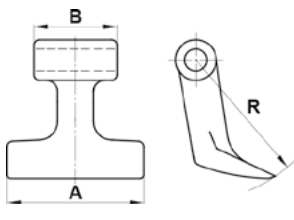
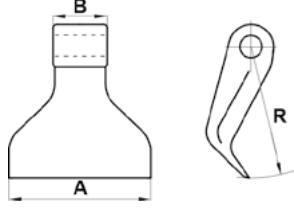
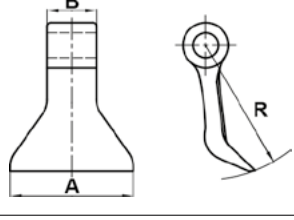
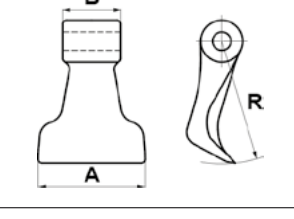
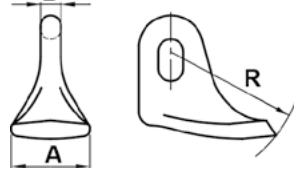

Marca della macchina Machine brand name Marke der Maschine Marque de la machine Марка машины	Codice Nr. Ref. Nr. Re. Nr. Ref. Nr. Код №		Quote Dimensions Abmessungen Dimensions Размеры mm	Piatto Plate Platte Plaque Профиль mm	Fori Holes Löcher Trous Отверстия Ø mm	Peso Weight Gewicht Poids Вес gr	Passo Pitch Winde Pas Шаг mm
Berti	Mazza 58/20		A = 138 B = 86 R = 99	—	20,5	2300	—
Nobili	Mazza 59/26		A = 88 B = 51 R = 182	—	26,5	2200	—
Palladino	Mazza 61/12		A = 74 B = 46 R = 76	—	12,0	360	—
Sauerburger	Mazza 63/20		A = 130 B = 50 R = 120	—	20,5	1770	—
Agrimaster Calderoni	Mazza 64/20		A = 100 B = 40 R = 103	—	20,5	650	—
Agrimaster	Mazza 66/14		A = 85 B = 47 R = 100	—	14,5	810	—
Bonford	Mazza 71		A = 50 B = 13 R = 80	—	16x27	490	—

MAZZE PER TRINCIASARMENTI
Hammer
Hammerschlegel
Marteaux pour broyeurs
Молотковые ножи для мульчирования

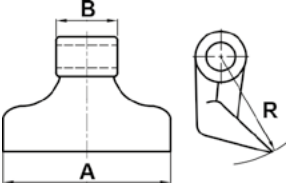
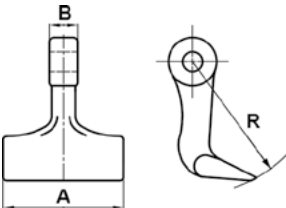
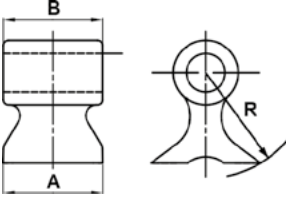
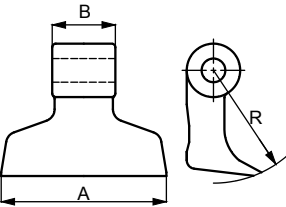
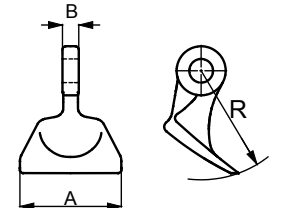
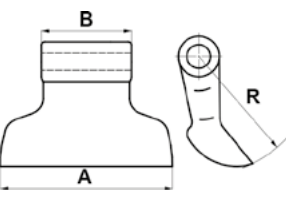
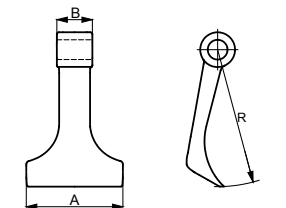

Marca della macchina Machine brand name Marke der Maschine Marque de la machine Марка машины	Codice Nr. Ref. Nr. Re. Nr. Ref. Nr. Код №		Quote Dimensions Abmessungen Dimensions Размеры mm	Piatto Plate Platte Plaque Профиль mm	Fori Holes Löcher Trous Отверстия Ø mm	Peso Weight Gewicht Poids Вес gr	Passo Pitch Winde Pas Шаг mm
Falc Cobra	Mazza 76/25		A = 148 B = 54 R = 96	—	25,5	1450	—
Ferri	Mazza 80/16		A = 100 B = 24 R = 110	—	16,5	1050	—
Berti forestale	Mazza 83/31		A = 70 B = 80 R = 85	—	31	1900	—
Berti nuovo tipo	Mazza 84/19		A = 136 B = 52 R = 93	—	19,5	1880	—
Calderoni Ubaldi Acma	Mazza 86/14		A = 62 B = 10 R = 67	—	14,5	215	—
Tortella	Mazza 88/22		A = 165 B = 96 R = 115	—	22,5	2370	—
Maschio T30004027	Mazza 90/25		A = 125 B = 46 R = 177	—	25,5	1550	—

Tutti i modelli sono di nostra produzione e non originali.
 All models are of our manufacture and are not original.
 Alle unsere Landwirtschaftliche erzeugnisse sind unsere produktion und sind nicht original.
 Tous les modèles sont notre production et ne sont pas des produits d'origine.
 Все модели нашего производства и не являются оригинальными.

N.B. Pesi e misure sopra descritti sono puramente indicativi.
 N.B. The above weights and dimensions are given for reference only.
 N.B. Die obengenannten Gewichte und Abmessungen sind richtungsweisend.
 N.B. Les poids et les dimensions indiqués ci-dessus sont donnés à titre indicatif.
 N.B. Указанные вес и размеры, являются ориентировочными.

© La riproduzione
 anche parziale
 del presente catalogo
 è vietata.

MAZZE PER TRINCIASARMENTI
Hammer
Hammerschlegel
Marteaux pour broyeurs
Молотковые ножи для мульчирования

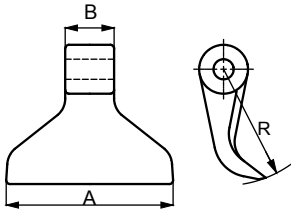
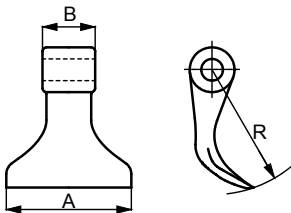
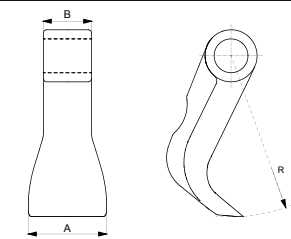
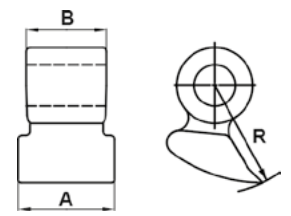
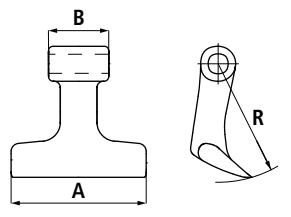
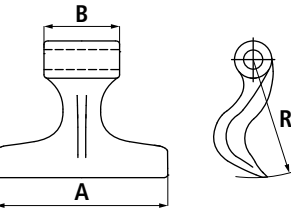
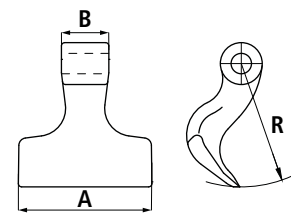

Marca della macchina Machine brand name Marke der Maschine Marque de la machine Марка машины	Codice Nr. Ref. Nr. Re. Nr. Ref. Nr. Код №		Quote Dimensions Abmessungen Dimensions Размеры mm	Piatto Plate Platte Plaque Профиль mm	Fori Holes Löcher Trous Отверстия Ø mm	Peso Weight Gewicht Poids Вес gr	Passo Pitch Winde Pas Шаг mm
Berti	Mazza 91/16		A = 138 B = 40 R = 95	—	16,5	1800	—
Sicma erba TG	Mazza 93/16		A = 95 B = 40 R = 95	—	16,5	620	—
McConnel 73-90-276	Mazza 95/26		A = 60 B = 37 R = 125	—	26,5	1000	—
Berti forestale Seppi forestale	Mazza 102/30		A = 71 B = 60 R = 80	—	30,5	1760	—
Del Morino	Mazza 106/12		A = 85 B = 39 R = 74,5	—	12,5	420	—
Facma	Mazza 107/18		A = 165 B = 73 R = 114	—	18,5	1800	—
Facma	Mazza 110/18		A = 122 B = 44 R = 112	—	18,5	1500	—

MAZZE PER TRINCIASARMENTI
Hammer
Hammerschlegel
Marteaux pour broyeurs
Молотковые ножи для мульчирования

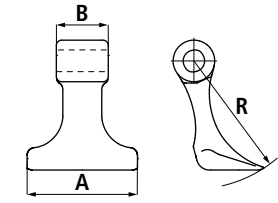
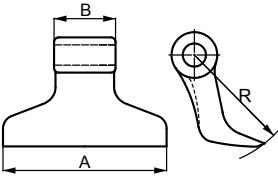
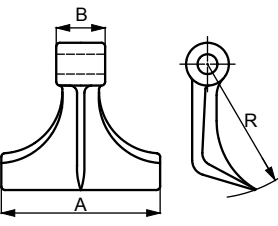
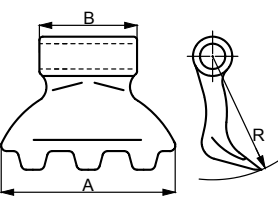
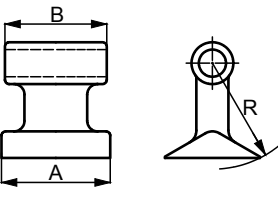
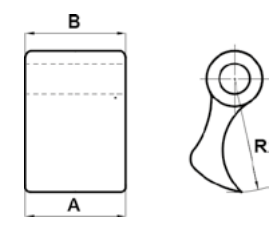
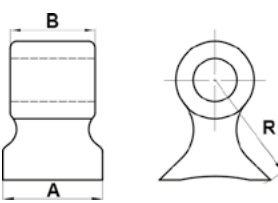

Marca della macchina Machine brand name Marke der Maschine Marque de la machine Марка машины	Codice Nr. Ref. Nr. Re. Nr. Ref. Nr. Код №		Quote Dimensions Abmessungen Dimensions Размеры mm	Piatto Plate Platte Plaque Профиль mm	Fori Holes Löcher Trous Отверстия Ø mm	Peso Weight Gewicht Poids Вес gr	Passo Pitch Winde Pas Шаг mm
Maschio M07400950	Mazza 111/16		A = 85 B = 41 R = 100	—	16,5	750	—
Calderoni	Mazza 150/20		A = 145 B = 55 R = 98	—	20,5	1350	—
Nobili	279025		A = 120 B = 36 R = 110	—	16,5	1210	—
Celli Palladino HMF	298012		A = 155 B = 69 R = 85	—	16,5	1570	—
Braber Ferri	397001		A = 78 B = 73 R = 76	—	16,5	930	—
VD 80	900018		A = 80 B = 80 R = 90	—	24,5	1550	—
Seppi 194.02.025	900023		A = 70 B = 60 R = 80	—	30,5	1640	—

Tutti i modelli sono di nostra produzione e non originali.
 All models are of our manufacture and are not original.
 Alle unsere Landwirtschaftliche erzeugnisse sind unsere produktion und sind nicht original.
 Tous les modèles sont notre production et ne sont pas des produits d'origine.
 Все модели нашего производства и не являются оригинальными.

N.B. Pesi e misure sopra descritti sono puramente indicativi.
 N.B. The above weights and dimensions are given for reference only.
 N.B. Die obengenannten Gewichte und Abmessungen sind richtungsweisend.
 N.B. Les poids et les dimensions indiqués ci-dessus sont donnés à titre indicatif.
 N.B. Указанные вес и размеры, являются ориентировочными.

© La riproduzione
 anche parziale
 del presente catalogo
 è vietata.

MAZZE PER TRINCIASARMENTI
Hammer
Hammerschlegel
Marteaux pour broyeurs
Молотковые ножи для мульчирования



Marca della macchina Machine brand name Marke der Maschine Marque de la machine Марка машины	Codice Nr. Ref. Nr. Re. Nr. Ref. Nr. Код №		Quote Dimensions Abmessungen Dimensions Размеры mm	Piatto Plate Platte Plaque Профиль mm	Fori Holes Löcher Trous Отверстия Ø mm	Peso Weight Gewicht Poids Вес gr	Passo Pitch Winde Pas Шаг mm
VITI							
Vite Esagono 27 completa di dado autobloccante esagono 24	656028	Classe 10.9	16×90	—	—	200	2
Vite Esagono 22 completa di dado autobloccante esagono 22	656030	Classe 10.9	14×90	—	—	180	2
Vite Esagono 27 completa di dado autobloccante esagono 24	656032	Classe 10.9	16×100	—	—	210	2
Vite Esagono 27 completa di dado autobloccante esagono 24	656036	Classe 10.9	16×130	—	—	280	2
Vite Esagono 32 completa di dado autobloccante esagono 30	656041	Classe 10.9	20×120	—	—	320	2,5

SUPPORTI							
Supporto mazza	01		<p>A = 50 B = 30 C = 16</p>	50×16	16,5	260	—
Supporto mazza con esagono	01/E		<p>A = 50 B = 30 C = 16</p>	50×16	16,5	260	—
Supporto mazza	02		<p>A = 50 B = 25,5 C = 18</p>	50×18	16,5	300	—

MAZZE PER TRINCIASARMENTI
Hammer
Hammerschlegel
Marteaux pour broyeurs
Молотковые ножи для мульчирования



Marca della macchina Machine brand name Marke der Maschine Marque de la machine Марка машины	Codice Nr. Ref. Nr. Re. Nr. Ref. Nr. Код №		Quote Dimensions Abmessungen Dimensions Размеры mm	Piatto Plate Platte Plaque Профиль mm	Fori Holes Löcher Trous Отверстия Ø mm	Peso Weight Gewicht Poids Вес gr	Passo Pitch Winde Pas Шаг mm
Supporto mazza con esagono	02/E		A = 50 B = 25,5 C = 18	50x18	16,5	280	—
Supporto mazza	03		A = 50 B = 30 C = 20	50x20	18,5	310	—
Supporto mazza con esagono	03/E		A = 50 B = 30 C = 20	50x20	18,5	300	—
Supporto mazza	04		A = 50 B = 32 C = 18	50x18	20,5	310	—
Supporto mazza con esagono	04/E		A = 50 B = 32 C = 18	50x18	20,5	300	—
Supporto mazza Orsi	05		A = 45 B = 25 C = 24	49x24	12,3	240	—
Supporto mazza Orsi	06		A = 54 B = 36 C = 28	50x28	16,5	460	—

Tutti i modelli sono di nostra produzione e non originali.
 All models are of our manufacture and are not original.
 Alle unsere Landwirtschaftliche erzeugnisse sind unsere produktion und sind nicht original.
 Tous les modèles sont notre production et ne sont pas des produits d'origine.
 Все модели нашего производства и не являются оригинальными.

N.B. Pesi e misure sopra descritti sono puramente indicativi.
 N.B. The above weights and dimensions are given for reference only.
 N.B. Die obengenannten Gewichte und Abmessungen sind richtungsweisend.
 N.B. Les poids et les dimensions indiqués ci-dessus sont donnés à titre indicatif.
 N.B. Указанные вес и размеры, являются ориентировочными.

© La riproduzione
 anche parziale
 del presente catalogo
 è vietata.

MAZZE PER TRINCIASARMENTI
Hammer
Hammerschlegel
Marteaux pour broyeur
Молотковые ножи для мульчирования



Marca della macchina Machine brand name Marke der Maschine Marque de la machine Марка машины	Codice Nr. Ref. Nr. Re. Nr. Ref. Nr. Код №		Quote Dimensions Abmessungen Dimensions Размеры mm	Piatto Plate Platte Plaque Профиль mm	Fori Holes Löcher Trous Отверстия Ø mm	Peso Weight Gewicht Poids Вес gr	Passo Pitch Winde Pas Шаг mm
Supporto mazza con esagono Orsi	06/E		A = 54 B = 36 C = 28	50x28	16,5	450	—
Supporto mazza Meaat	09		A = 50 B = 18 C = 18	50x18	16,5	350	—
Supporto mazza con esagono Meaat	09/E		A = 50 B = 18 C = 18	50x18	16,5	330	—
Supporto mazza Becchio	11		A = 52 B = 27 C = 18	50x18	19,5	290	—
Supporto mazza con esagono Becchio	11E		A = 52 B = 27 C = 18	50x18	19,5	270	—
Supporto mazza Willibald	12		A = 95 B = 26 C = 19	95x19	20,5	400	—
Supporto mazza con esagono Willibald	12E		A = 95 B = 26 C = 19	95x19	20,5	380	—

MAZZE PER TRINCIASARMENTI
Hammer
Hammerschlegel
Marteaux pour broyeurs
Молотковые ножи для мульчирования



Marca della macchina Machine brand name Marke der Maschine Marque de la machine Марка машины	Codice Nr. Ref. Nr. Re. Nr. Ref. Nr. Код №		Quote Dimensions Abmessungen Dimensions Размеры mm	Piatto Plate Platte Plaque Профиль mm	Fori Holes Löcher Trous Отверстия Ø mm	Peso Weight Gewicht Poids Вес gr	Passo Pitch Winde Pas Шаг mm
Supporto mazza Alpego	20		A = 50 B = 27,5 C = 18	50x18	18,5	350	—
Supporto mazza con esagono Alpego	20E		A = 50 B = 27,5 C = 18	50x18	18,5	330	—

Tutti i modelli sono di nostra produzione e non originali.
 All models are of our manufacture and are not original.
 Alle unsere Landwirtschaftliche erzeugnisse sind unsere produktion und sind nicht original.
 Tous les modèles sont notre production et ne sont pas des produits d'origine.
 Все модели нашего производства и не являются оригинальными.

N.B. Pesi e misure sopra descritti sono puramente indicativi.
 N.B. The above weights and dimensions are given for reference only.
 N.B. Die obengenannten Gewichte und Abmessungen sind richtungsweisend.
 N.B. Les poids et les dimensions indiqués ci-dessus sont donnés à titre indicatif.
 N.B. Указанные вес и размеры, являются ориентировочными.

© La riproduzione anche parziale del presente catalogo è vietata.





eurozappa

RICAMBI PER ARATRI
Spare parts for ploughs
Ersatzteile für Pflüge
Pieces detachees pour charrues
Компоненты для плугов







RICAMBI PER ARATRI
Spare parts for ploughs
Ersatzteile für Pflüge
Pieces detachees pour charrues
Компоненты для плугов



Marca della macchina Machine brand name Marke der Maschine Marque de la machine Марка машины	Codice Eurozappa Eurozappa Ref. Nr. Eurozappa Re. Nr. Ref. Nr. Eurozappa Код Еврозаппа №	Codice originale Original code Original kode Code d'origine Оригинальный код	DX / SX R / L R / L D / G П / Л	Spessore Thickness Stärke Épaisseur # mm	Peso Weight Gewicht Poids Bec Kg
--	--	--	---	--	---

DOWDESWELL					
LANDSIDE		DW950-164700	164700		12 4
LANDSIDE REVERSIBLE		DW950-1136700	1136700		12 5,80
REVERSIBLE POINT (FORGED)		DW950-1176598	1176598	DX	15 1,60
		DW950-1176599	1176599	SX	
REVERSIBLE POINT (FORGED)		DW950-147298	147298	DX	12 2,50
		DW950-147299	147299	SX	
SHARE		DW950-147898	147898	DX	8 1,90
		DW950-147899	147899	SX	

GREGOIRE BESSON					
LANDSIDE		GB951-173338	173338	DX	10 2,50
		GB951-173337	173337	SX	
LANDSIDE REVERSIBLE		GB951-173388	173388		12 4,80
MOULDBOARD		GB951-173428	173428	DX	8 21,00
		GB951-173427	173427	SX	

Tutti i modelli sono di nostra produzione e non originali.
 All models are of our manufacture and are not original.
 Alle unsere Landwirtschaftliche erzeugnisse sind unsere produktion und sind nicht original.
 Tous les modèles sont notre production et ne sont pas des produits d'origine.
 Все модели нашего производства и не являются оригинальными.

N.B. Pesi e misure sopra descritti sono puramente indicativi.
 N.B. The above weights and dimensions are given for reference only.
 N.B. Die obengenannten Gewichte und Abmessungen sind richtungsweisend.
 N.B. Les poids et les dimensions indiqués ci-dessus sont donnés à titre indicatif.
 N.B. Указанные вес и размеры, являются ориентировочными.

© La riproduzione
 anche parziale
 del presente catalogo
 è vietata.

RICAMBI PER ARATRI
Spare parts for ploughs
Ersatzteile für Pflüge
Pieces detachees pour charrues
Компоненты для плугов









Marca della macchina Machine brand name Marke der Maschine Marque de la machine Марка машины		Codice Eurozappa Eurozappa Ref. Nr. Eurozappa Re. Nr. Ref. Nr. Eurozappa Код Еврозаппа №	Codice originale Original code Original code Code d'origine Оригинальный код	DX / SX R / L R / L D / G П / Л	Spessore Thickness Stärke Epaisseur # mm	Peso Weight Gewicht Poids Bec Kg
MOULDBOARD		GB951-173436	173436	DX	8	15,50
		GB951-173435	173435	SX		
MOULDBOARD		GB951-173484	173484	DX	8	15,50
		GB951-173483	173483	SX		
POINT REVERSIBLE		GB951-173332	173332	DX	15	2,00
		GB951-173331	173331	SX		
POINT REVERSIBLE HARD FACED		GB951-173332RIP	173332	DX	15	2,20
		GB951-173331RIP	173331	SX		
POINT REVERSIBLE		GB951-173384	173384	DX	16	2,60
		GB951-173383	173383	SX		
POINT REVERSIBLE HARD FACED		GB951-173384RIP	173384	DX	16	2,80
		GB951-173383RIP	173383	SX		
POINT REVERSIBLE		GB951-177328	177328	DX	15	2,20
		GB951-177327	177327	SX		
SHARE		GB951-172418	172418	DX	12	4,70
		GB951-172417	172417	SX		
SHARE		GB951-172614	172614	DX	10	5,20
		GB951-172613	172613	SX		
SHIN		GB951-173326	173326	DX	7	1,80
		GB951-173325	173325	SX		

RICAMBI PER ARATRI
Spare parts for ploughs
Ersatzteile für Pflüge
Pieces detachees pour charrues
Компоненты для плугов



Marca della macchina Machine brand name Marke der Maschine Marque de la machine Марка машины		Codice Eurozappa Eurozappa Ref. Nr. Eurozappa Re. Nr. Ref. Nr. Eurozappa Код Еврозаппа №	Codice originale Original code Original kode Code d'origine Оригинальный код	DX / SX R / L R / L D / G П / Л	Spessore Thickness Stärke Epaisseur # mm	Peso Weight Gewicht Poids Bec Kg
SKIM POINT		GB951-19112	19112	DX	10	1,00
		GB951-19111	19111	SX		
SKIM POINT		GB951-19114	19114	DX	10	1,10
		GB951-19113	19113	SX		

KUHN-HUARD						
LANDSIDE		KH952-200645	200645		10	2,50
LANDSIDE REVERSIBLE		KH952-278075	278075		10	2,96
LANDSIDE REVERSIBLE		KH952-278077	278077		10	4,80
LANDSIDE		KH952-279130	279130	DX	10	4,80
		KH952-279131	279131	SX		
LANDSIDE		KH952-279140	279140		10	5,30
LANDSIDE		KH952-761108	761108		10	4,70
LANDSIDE PROTECTION		KH952-279138	279138	DX	10	0,80
		KH952-279139	279139	SX		











Tutti i modelli sono di nostra produzione e non originali.
 All models are of our manufacture and are not original.
 Alle unsere Landwirtschaftliche erzeugnisse sind unsere produktion und sind nicht original.
 Tous les modèles sont notre production et ne sont pas des produits d'origine.
 Все модели нашего производства и не являются оригинальными.

N.B. Pesi e misure sopra descritti sono puramente indicativi.
 N.B. The above weights and dimensions are given for reference only.
 N.B. Die obengenannten Gewichte und Abmessungen sind richtungsweisend.
 N.B. Les poids et les dimensions indiqués ci-dessus sont donnés à titre indicatif.
 N.B. Указанные вес и размеры, являются ориентировочными.

© La riproduzione
 anche parziale
 del presente catalogo
 è vietata.

RICAMBI PER ARATRI
Spare parts for ploughs
Ersatzteile für Pflüge
Pieces detachees pour charrues
Компоненты для плугов



Marca della macchina Machine brand name Marke der Maschine Marque de la machine Марка машины		Codice Eurozappa Eurozappa Ref. Nr. Eurozappa Re. Nr. Ref. Nr. Eurozappa Код Еврозаппа №	Codice originale Original code Original code Code d'origine Оригинальный код	DX / SX R / L R / L D / G П / Л	Spessore Thickness Stärke Epaisseur # mm	Peso Weight Gewicht Poids Bec Kg
LANDSIDE PROTECTION		KH952-761106	761106	DX	10	0,90
		KH952-761107	761107	SX		
LANDSIDE PROTECTION		KH952-761110	761110	DX	10	0,80
		KH952-761111	761111	SX		
MOULDBOARD CORP L6		KH952-616138	616138	DX	8	18,00
		KH952-616139	616139	SX		
REVERSIBLE POINT		KH952-622128	622128	DX	12	2,00
		KH952-622129	622129	SX		
REVERSIBLE POINT		KH952-622180	622180	DX	12	2,00
		KH952-622181	622181	SX		
REVERSIBLE POINT HEAVY DUTY		KH952-622174	622174	DX	15	2,50
		KH952-622175	622175	SX		
REVERSIBLE SKIM POINT		KH952-631112	631112		10	2,10
SHARE 16"		KH952-622136	622136	DX	10	7,00
		KH952-622137	622137	SX		
SHARE 16"		KH952-622172	622172	DX	10	6,20
		KH952-622173	622173	SX		
SHIN		KH952-619120	619120	DX	7	2,30
		KH952-619121	619121	SX		

RICAMBI PER ARATRI
Spare parts for ploughs
Ersatzteile für Pflüge
Pieces detachees pour charrues
Компоненты для плугов



Marca della macchina Machine brand name Marke der Maschine Marque de la machine Марка машины		Codice Eurozappa Eurozappa Ref. Nr. Eurozappa Re. Nr. Ref. Nr. Eurozappa Код Еврозаппа №	Codice originale Original code Original kode Code d'origine Оригинальный код	DX / SX R / L R / L D / G П / Л	Spessore Thickness Stärke Epaisseur # mm	Peso Weight Gewicht Poids Bec Kg
SHIN		KH952-619172	619172	DX	8	2,50
		KH952-619173	619173	SX		
SHIN		KH952-619200	619200	DX	7	1,35
		KH952-619201	619201	SX		
SKIM POINT		KH952-631100	631100	DX	10	1,30
		KH952-631101	631101	SX		
SKIM POINT		KH952-631102	631102	DX	8	1,30
		KH952-631103	631103	SX		
SKIM POINT		KH952-631104	631104	DX	10	2,10
		KH952-631105	631105	SX		

KVERNELAND						
LANDSIDE		KV953-073608	073608		11	5,27
LANDSIDE		KV953-073609	073609		11	7,91
LANDSIDE PROTECTION		KV953-063600	063600		12	1,40
LANDSIDE PROTECTION		KV953-073614	073614		12	1,00

Tutti i modelli sono di nostra produzione e non originali.
 All models are of our manufacture and are not original.
 Alle unsere Landwirtschaftliche erzeugnisse sind unsere produktion und sind nicht original.
 Tous les modèles sont notre production et ne sont pas des produits d'origine.
 Все модели нашего производства и не являются оригинальными.

N.B. Pesi e misure sopra descritti sono puramente indicativi.
 N.B. The above weights and dimensions are given for reference only.
 N.B. Die obengenannten Gewichte und Abmessungen sind richtungsweisend.
 N.B. Les poids et les dimensions indiqués ci-dessus sont donnés à titre indicatif.
 N.B. Указанные вес и размеры, являются ориентировочными.

© La riproduzione
 anche parziale
 del presente catalogo
 è vietata.

RICAMBI PER ARATRI
Spare parts for ploughs
Ersatzteile für Pflüge
Pieces detachees pour charrues
Компоненты для плугов



Marca della macchina Machine brand name Marke der Maschine Marque de la machine Марка машины		Codice Eurozappa Eurozappa Ref. Nr. Eurozappa Re. Nr. Ref. Nr. Eurozappa Код Еврозаппа №	Codice originale Original code Original code Code d'origine Оригинальный код	DX / SX R / L R / L D / G П / Л	Spessore Thickness Stärke Epaisseur # mm	Peso Weight Gewicht Poids Bec Kg
MOULDBOARD		KV953-063283	063283	DX	8	19,00
		KV953-063293	063293	SX		
MOULDBOARD		KV953-073286	073286	DX	8	21,00
		KV953-073287	073287	SX		
MOULDBOARD		KV953-073290	073290	DX	8	19,60
		KV953-073291	073291	SX		
REVERSIBLE POINT		KV953-053090	053090	DX	12	1,30
		KV953-063090	063090	SX		
SHARE 14"		KV953-073002	073002	DX	10	4,70
		KV953-073003	073003	SX		
SHARE 16"		KV953-073004	073004	DX	10	5,10
		KV953-073005	073005	SX		
SHARE 16"		KV953-073004-2	073004-2	DX	10	4,00
		KV953-073005-2	073005-2	SX		
SHARE 18"		KV953-073006	073006	DX	10	5,80
		KV953-073007	073007	SX		
SHARE 18"		KV953-073006-2	073006-2	DX	10	4,80
		KV953-073007-2	073007-2	SX		
SHARE POINT		KV953-073004/6-1	073004/6-1	DX	11	1,90
		KV953-073005/7-1	073005/7-1	SX		

RICAMBI PER ARATRI
Spare parts for ploughs
Ersatzteile für Pflüge
Pieces detachees pour charrues
Компоненты для плугов



Marca della macchina Machine brand name Marke der Maschine Marque de la machine Марка машины		Codice Eurozappa Eurozappa Ref. Nr. Eurozappa Re. Nr. Ref. Nr. Eurozappa Код Еврозаппа №	Codice originale Original code Original kode Code d'origine Оригинальный код	DX / SX R / L R / L D / G П / Л	Spessore Thickness Stärke Epaisseur # mm	Peso Weight Gewicht Poids Bec Kg
SHIN		KV953-063240	063240	DX	8	1,00
		KV953-063250	063250	SX		
SHIN		KV953-073230	073230	DX	8	1,80
		KV953-073231	073231	SX		
SHIN		KV953-073250	073250	DX	8	1,50
		KV953-073251	073251	SX		
SHIN		KV953-073256	073256	DX	8	1,50
		KV953-073257	073257	SX		
SKIM POINT		KV953-056873	056873	DX	8	1,00
		KV953-066873	066873	SX		
SKIM POINT REVERSIBLE		KV953-066868	066868	DX	8	1,60
		KV953-066869	066869	SX		
SHARE 16"		KV953-073054	073054	DX	10	5,10
		KV953-073055	073055	SX		
SHARE 16"		KV953-073056	073056	DX	10	5,30
		KV953-073057	073057	SX		
SHARE 18"		KV953-073080	073080	DX	10	6,30
		KV953-073081	073081	SX		

Tutti i modelli sono di nostra produzione e non originali.
 All models are of our manufacture and are not original.
 Alle unsere Landwirtschaftliche erzeugnisse sind unsere produktion und sind nicht original.
 Tous les modèles sont notre production et ne sont pas des produits d'origine.
 Все модели нашего производства и не являются оригинальными.

N.B. Pesi e misure sopra descritti sono puramente indicativi.
 N.B. The above weights and dimensions are given for reference only.
 N.B. Die obengenannten Gewichte und Abmessungen sind richtungsweisend.
 N.B. Les poids et les dimensions indiqués ci-dessus sont donnés à titre indicatif.
 N.B. Указанные вес и размеры, являются ориентировочными.

© La riproduzione
 anche parziale
 del presente catalogo
 è vietata.

RICAMBI PER ARATRI
Spare parts for ploughs
Ersatzteile für Pflüge
Pieces detachees pour charrues
Компоненты для плугов











Marca della macchina Machine brand name Marke der Maschine Marque de la machine Марка машины	Codice Eurozappa Eurozappa Ref. Nr. Eurozappa Re. Nr. Ref. Nr. Eurozappa Код Еврозаппа №	Codice originale Original code Original kode Code d'origine Оригинальный код	DX / SX R / L R / L D / G П / Л	Spessore Thickness Stärke Epaisseur # mm	Peso Weight Gewicht Poids Bec Kg
--	--	--	---	--	---

LEMKEN					
LANDSIDE		LK954-3411460	3411460		12 6,90
LANDSIDE		LK954-3411504	3411504		12 4,64
LANDSIDE		LK954-3411508	3411508		12 5,90
LANDSIDE PROTECTION		LK954-3401900	3401900	DX	10 1,10
		LK954-3401901	3401901	SX	
MOULBOARD STRIPE TYPE BS42		LK954-3444042	3444042	DX	10 7,38
		LK954-3444043	3444043	SX	
MOULBOARD STRIPE TYPE BS42-40		LK954-3444020	3444020	DX	11 3,40
		LK954-3444021	3444021	SX	
MOULBOARD STRIPE TYPE BS42-40		LK954-3444030	3444030	DX	11 4,41
		LK954-3444031	3444031	SX	
MOULBOARD STRIPE TYPE BS42-40-20		LK954-3444010	3444010	DX	10 2,97
		LK954-3444011	3444011	SX	
MOULBOARD TOP STRIPE TYPE BS42-40-20		LK954-3444012	3444012	DX	10 4,83
		LK954-3444013	3444013	SX	

RICAMBI PER ARATRI
Spare parts for ploughs
Ersatzteile für Pflüge
Pieces detachees pour charrues
Компоненты для плугов



Marca della macchina Machine brand name Marke der Maschine Marque de la machine Марка машины		Codice Eurozappa Eurozappa Ref. Nr. Eurozappa Re. Nr. Ref. Nr. Eurozappa Код Еврозаппа №	Codice originale Original code Original kode Code d'origine Оригинальный код	DX / SX R / L R / L D / G П / Л	Spessore Thickness Stärke Epaisseur # mm	Peso Weight Gewicht Poids Bec Kg
MOULBOARD TYPE B35		LK954-3441034	3441034	DX	8	15,80
		LK954-3441035	3441035	SX		
MOULBOARD TYPE B40		LK954-3441040	3441040	DX	8	18,14
		LK954-3441041	3441041	SX		
POINT		LK954-3364050	3364050	DX	12	2,00
		LK954-3364051	3364051	SX		
POINT		LK954-3364150	3364150	DX	15	2,60
		LK954-3364151	3364151	SX		
POINT HARD FACED		LK954-3364150RIP	3364150	DX	15	2,80
		LK954-3364151RIP	3364151	SX		
REVERSIBLE POINT		LK954-3365534	3365534	DX	12	1,30
		LK954-3365535	3365535	SX		
REVERSIBLE POINT		LK954-3365540	3365540	DX	12	2,30
		LK954-3365541	3365541	SX		
SHARE 14"		LK954-3351956	3351956	DX	10	2,70
		LK954-3351957	3351957	SX		
SHARE 14"		LK954-3352010	3352010	DX	10	3,20
		LK954-3352011	3352011	SX		
SHARE 16"		LK954-3352020	3352020	DX	10	4,30
		LK954-3352021	3352021	SX		

Tutti i modelli sono di nostra produzione e non originali.
 All models are of our manufacture and are not original.
 Alle unsere Landwirtschaftliche erzeugnisse sind unsere produktion und sind nicht original.
 Tous les modèles sont notre production et ne sont pas des produits d'origine.
 Все модели нашего производства и не являются оригинальными.

N.B. Pesi e misure sopra descritti sono puramente indicativi.
 N.B. The above weights and dimensions are given for reference only.
 N.B. Die obengenannten Gewichte und Abmessungen sind richtungsweisend.
 N.B. Les poids et les dimensions indiqués ci-dessus sont donnés à titre indicatif.
 N.B. Указанные вес и размеры, являются ориентировочными.

© La riproduzione
 anche parziale
 del presente catalogo
 è vietata.







RICAMBI PER ARATRI
Spare parts for ploughs
Ersatzteile für Pflüge
Pieces detachees pour charrues
Компоненты для плугов



Marca della macchina Machine brand name Marke der Maschine Marque de la machine Марка машины		Codice Eurozappa Eurozappa Ref. Nr. Eurozappa Re. Nr. Ref. Nr. Eurozappa Код Еврозаппа №	Codice originale Original code Original code Code d'origine Оригинальный код	DX / SX R / L R / L D / G П / Л	Spessore Thickness Stärke Epaisseur # mm	Peso Weight Gewicht Poids Bec Kg
SHARE 18"		LK954-3352030	3352030	DX	10	4,60
		LK954-3352031	3352031	SX		
SHARE 18"		LK954-3352130	3352130	DX	12	5,60
		LK954-3352131	3352131	SX		
SHARE 18" HARD FACED		LK954-3352230RIP	3352230	DX	10	4,80
		LK954-3352231RIP	3352231	SX		
SHARE 20"		LK954-3352034	3352034	DX	10	5,20
		LK954-3352035	3352035	SX		
SHARE 20"		LK954-3352134	3352134	DX	12	6,30
		LK954-3352135	3352135	SX		
SHARE 20" HARD FACED		LK954-3352234RIP	3352234	DX	10	5,40
		LK954-3352235RIP	3352235	SX		
SHIN		LK954-3451000	3451000	DX	7	2,38
		LK954-3451001	3451001	SX		
SHIN		LK954-3451004	3451004	DX	7	2,20
		LK954-3451005	3451005	SX		
SKIM BOARD		LK954-3470650	3470650	DX	5	1,55
		LK954-3470651	3470651	SX		
SKIM SHARE		LK954-3363710	3363710	DX	8	1,40
		LK954-3363711	3363711	SX		

RICAMBI PER ARATRI
Spare parts for ploughs
Ersatzteile für Pflüge
Pieces detachees pour charrues
Компоненты для плугов



Marca della macchina Machine brand name Marke der Maschine Marque de la machine Марка машины		Codice Eurozappa Eurozappa Ref. Nr. Eurozappa Re. Nr. Ref. Nr. Eurozappa Код Еврозаппа №	Codice originale Original code Original kode Code d'origine Оригинальный код	DX / SX R / L R / L D / G П / Л	Spessore Thickness Stärke Epaisseur # mm	Peso Weight Gewicht Poids Bec Kg
SKIM SHARE		LK954-3363712	3363712	DX	8	0,90
		LK954-3363713	3363713	SX		
SKIM SHARE		LK954-3363714	3363714	DX	8	1,00
		LK954-3363715	3363715	SX		
SKIM SHARE		LK954-3363720	3363720	DX	8	1,10
		LK954-3363721	3363721	SX		
SKIM SHARE		LK954-3363724	3363724		8	2,00
TRASHBOARD		LK954-3470860	3470860	DX	8	3,30
		LK954-3470861	3470861	SX		
MOLDBOARD M3		LK954-3470620	3470620	DX	5	2,35
		LK954-3470621	3470621	SX		

OVERUM

REVERSIBLE POINT		OV957-94608	94608	DX	10	1,80
		OV957-94609	94609	SX		

RABEWERK

LANDSIDE FRONT REVERSIBLE		RW955-VP202	VP 202-2708.07.02		12	2,60
---------------------------	---	-------------	-------------------	--	----	------

Tutti i modelli sono di nostra produzione e non originali.
 All models are of our manufacture and are not original.
 Alle unsere Landwirtschaftliche erzeugnisse sind unsere produktion und sind nicht original.
 Tous les modèles sont notre production et ne sont pas des produits d'origine.
 Все модели нашего производства и не являются оригинальными.

N.B. Pesi e misure sopra descritti sono puramente indicativi.
 N.B. The above weights and dimensions are given for reference only.
 N.B. Die obengenannten Gewichte und Abmessungen sind richtungsweisend.
 N.B. Les poids et les dimensions indiqués ci-dessus sont donnés à titre indicatif.
 N.B. Указанные вес и размеры, являются ориентировочными.

© La riproduzione anche parziale del presente catalogo è vietata.



RICAMBI PER ARATRI
Spare parts for ploughs
Ersatzteile für Pflüge
Pieces detachees pour charrues
Компоненты для плугов







Marca della macchina Machine brand name Marke der Maschine Marque de la machine Марка машины		Codice Eurozappa Eurozappa Ref. Nr. Eurozappa Re. Nr. Ref. Nr. Eurozappa Код Еврозаппа №	Codice originale Original code Original code Code d'origine Оригинальный код	DX / SX R / L R / L D / G П / Л	Spessore Thickness Stärke Epaisseur # mm	Peso Weight Gewicht Poids Вес Kg
LANDSIDE FRONT REVERSIBLE		RW955-VP292-0	VP 292-0 - 2701.15.00	DX-SX	12	3,50
LANDSIDE PROTECTION		RW955-XP4	XP4 - 2708.15.00		8	0,90
LANDSIDE PROTECTION		RW955-XP6	XP6- 2708.14.00		7	3,20
LANDSIDE REAR REVERSIBLE		RW955-WP203	WP 203- 2708.07.01		12	3,90
LANDSIDE REAR REVERSIBLE		RW955-WP292	WP 292- 2701.14.00		12	5,60
LANDSIDE REVERSIBLE		RW955-VP351W	VP 351W		12	3,60
LANDSIDE REVERSIBLE		RW955-WP351W	WP 351 W -2751.03.05		12	4,70
REVERSIBLE POINT		RW955-MP293	MP 293	DX	12	1,20
		RW955-MP293L	MP 293L	SX		
REVERSIBLE POINT		RW955-MP332	MP 332	DX	12	1,10
		RW955-MP332L	MP 332L	SX		
REVERSIBLE POINT		RW955-MP350	MP 350	DX	12	1,10
		RW955-MP350L	MP 350L	SX		

RICAMBI PER ARATRI
Spare parts for ploughs
Ersatzteile für Pflüge
Pieces detachees pour charrues
Компоненты для плугов



Marca della macchina Machine brand name Marke der Maschine Marque de la machine Марка машины		Codice Eurozappa Eurozappa Ref. Nr. Eurozappa Re. Nr. Ref. Nr. Eurozappa Код Еврозаппа №	Codice originale Original code Original kode Code d'origine Оригинальный код	DX / SX R / L R / L D / G П / Л	Spessore Thickness Stärke Epaisseur # mm	Peso Weight Gewicht Poids Bec Kg
SKIM POINT		RW955-SDG14/16	SDG 14/16	DX	8	1,00
		RW955-SDG14/16L	SDG 14/16L	SX		
SKIM POINT		RW955-SDG181	SDG 181L	DX	8	1,00
		RW955-SDG181L	SDG 181L	SX		
SHARE		RW955-SSP350WSE	SSP 350 WSE	DX	13	6,10
		RW955-SSP350WSEL	SSP 350 WSEL	SX		

VOGEL&NOOT						
LANDSIDE		VN956-PK803401	PK 8.034.01	DX	12	4,40
		VN956-PK803501	PK 8.035.01	SX		
LANDSIDE PROTECTION		VN956-P5801101	P5801 101		12	2,70
REVERSIBLE POINT (FORGED)		VN956-PK8.011.01	PK 8.011.01	DX	14	1,50
		VN956-PK8.011.02	PK 8.011.02	SX		
SHIN		VN956-PK800501	PK 800501	DX	8	2,20
		VN956-PK800601	PK 800601	SX		
SHARE 16"		VN956-PK701301	PK7.013.01	DX	12	5,50
		VN956-PK701401	PK7.014.01	SX		

Tutti i modelli sono di nostra produzione e non originali.
 All models are of our manufacture and are not original.
 Alle unsere Landwirtschaftliche erzeugnisse sind unsere produktion und sind nicht original.
 Tous les modèles sont notre production et ne sont pas des produits d'origine.
 Все модели нашего производства и не являются оригинальными.

N.B. Pesi e misure sopra descritti sono puramente indicativi.
 N.B. The above weights and dimensions are given for reference only.
 N.B. Die obengenannten Gewichte und Abmessungen sind richtungsweisend.
 N.B. Les poids et les dimensions indiqués ci-dessus sont donnés à titre indicatif.
 N.B. Указанные вес и размеры, являются ориентировочными.

© La riproduzione
 anche parziale
 del presente catalogo
 è vietata.



A stylized orange globe with a grid of latitude and longitude lines. A banner is draped across the middle of the globe, containing the word "eurozappa" in a bold, lowercase, sans-serif font.

eurozappa

MOLLE
Cultivator tines
Feingrubberzinken
Dents pour vibroculteurs
Культиваторные стойки

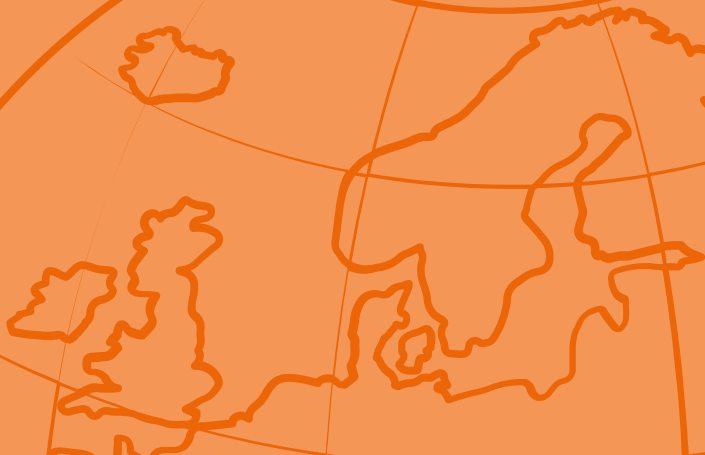



eurozappa



MOLLE
Cultivator tines
Feingrubberzinken
Dents pour vibroculteurs
Культиваторные стойки



MOLLA FLEX 32x10

S-Tine 32x10
 Kultizinke 32x10
 Dent de vibroculteur 32x10
 S-образная стойка 32x10

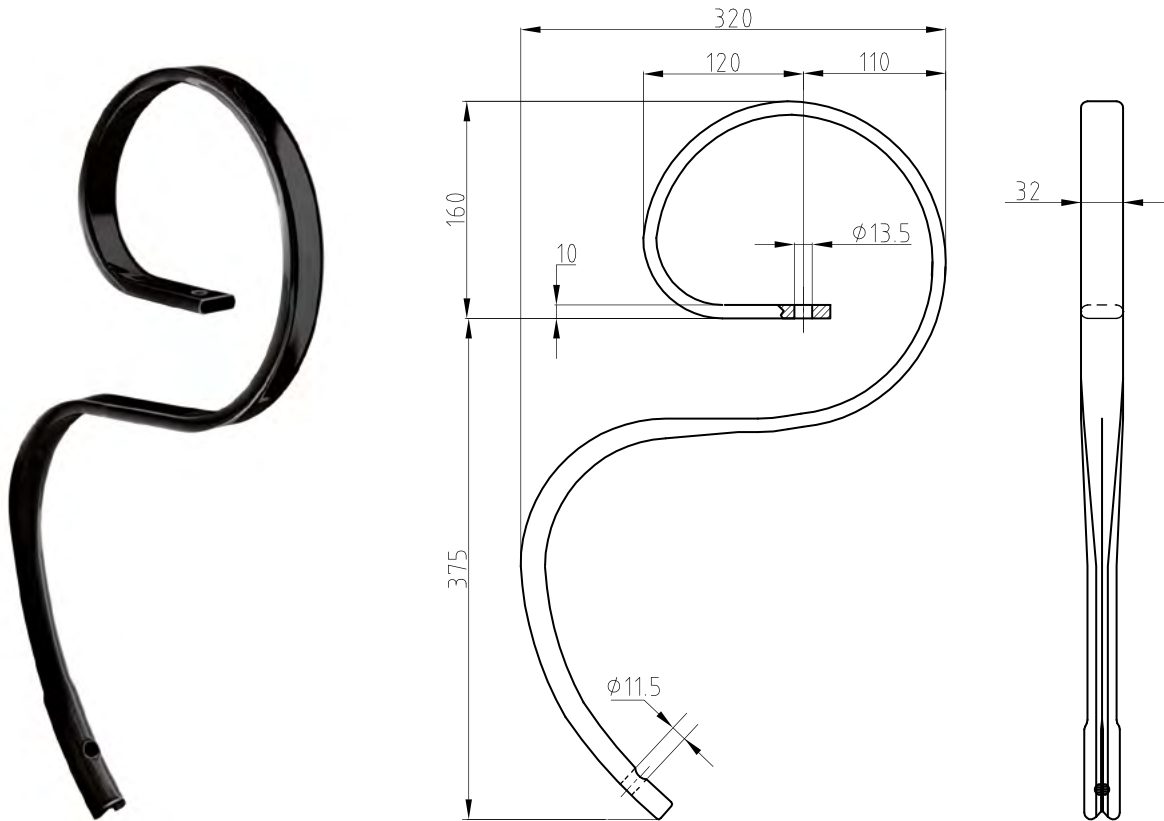

Codice Nr. Ref. Nr. Re. Nr. Ref. Nr. Код №		Quote Dimensions Abmessungen Dimensions Размеры mm	Vomere Point Schar Soc Лана mm	Bullone Bolt Schrauben Boulon Болт	Peso Weight Gewicht Poids Вес gr
F10SVV	Molla senza vomere	32x10	—	—	2,67
F10CVV	Molla con vomere reversibile 550001	32x10	40x5x190	10x38	3
F10CVV6	Molla con vomere reversibile 550031	32x10	40x6x190	10x38	3,1
F10CVV8	Molla con vomere reversibile 550102	32x10	40x8x210	10x38	3,2
F10CVV105	Molla con vomere a lancia 550027	32x10	105x4	10x38	3,05
F10CVV150	Molla con vomere a lancia 550028	32x10	150x4	10x38	3,4
F10CVVZO	Molla con vomere zampa d'oca 550018	32x10	70x4	10x38	3,2
F10CVV blu	Molla con vomere reversibile blu 550031	32x10	40x6x190	10x38	3,2

Tutti i modelli sono di nostra produzione e non originali.
 All models are of our manufacture and are not original.
 Alle unsere Landwirtschaftliche erzeugnisse sind unsere produktion und sind nicht original.
 Tous les modèles sont notre production et ne sont pas des produits d'origine.
 Все модели нашего производства и не являются оригинальными.

N.B. Pesi e misure sopra descritti sono puramente indicativi.
 N.B. The above weights and dimensions are given for reference only.
 N.B. Die obengenannten Gewichte und Abmessungen sind richtungsweisend.
 N.B. Les poids et les dimensions indiqués ci-dessus sont donnés à titre indicatif.
 N.B. Указанные вес и размеры, являются ориентировочными.

© La riproduzione
 anche parziale
 del presente catalogo
 è vietata.

MOLLE
Cultivator tines
Feingrubberzinken
Dents pour vibroculteurs
Культиваторные стойки



MOLLA FLEX 32x12

S-Tine 32x12
 Kultizinke 32x12
 Dent de vibroculteur 32x12
 S-образная стойка 32x12

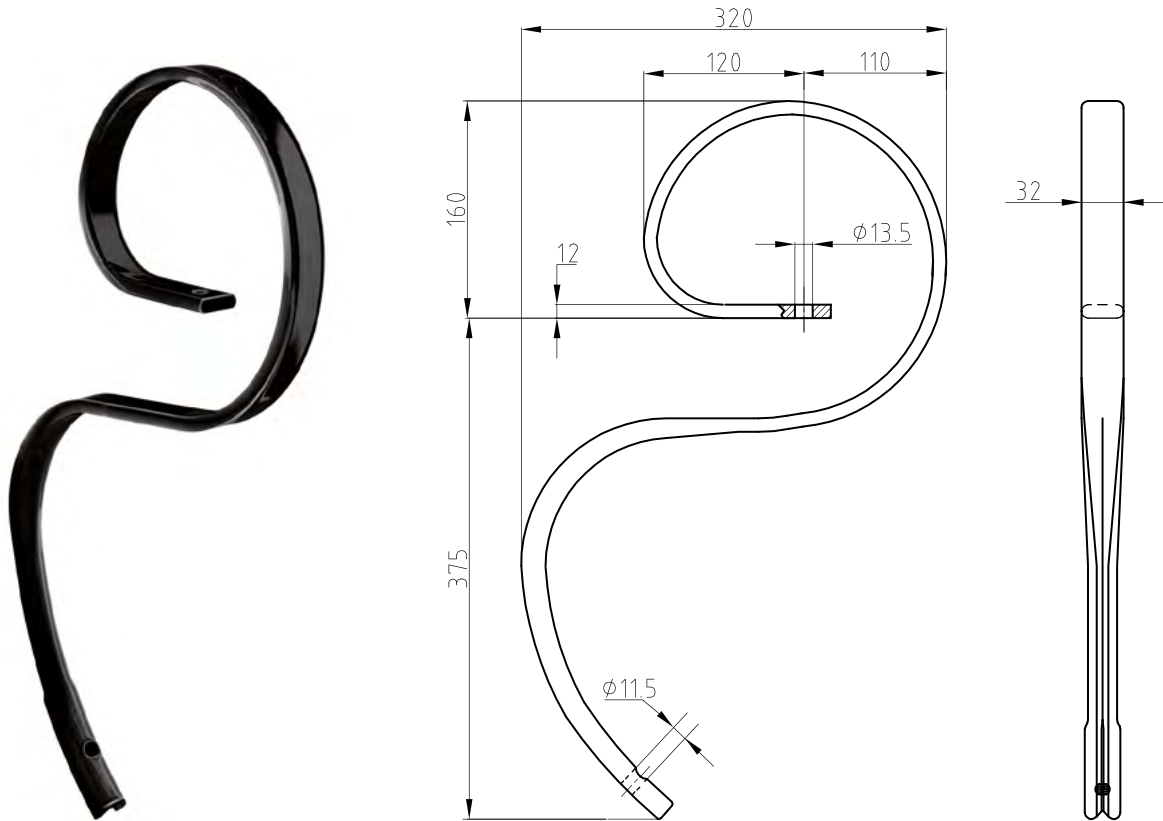

Codice Nr. Ref. Nr. Re. Nr. Ref. Nr. Код №		Quote Dimensions Abmessungen Dimensions Размеры mm	Vomere Point Schar Soc Лана mm	Bullone Bolt Schrauben Boulon Болт	Peso Weight Gewicht Poids Вес gr
F12SVV	Molla senza vomere	32x12	—	—	2,67
F12CVV	Molla con vomere reversibile 550001	32x12	40x5x190	10x38	3
F12CVV6	Molla con vomere reversibile 550031	32x12	40x6x190	10x38	3,1
F12CVV8	Molla con vomere reversibile 550102	32x12	40x8x210	10x38	3,2
F12CVV105	Molla con vomere a lancia 550027	32x12	105x4	10x38	3,05
F12CVV150	Molla con vomere a lancia 550028	32x12	150x4	10x38	3,4
F12CVVZO	Molla con vomere zampa d'oca 550018	32x12	70x4	10x38	3,2
F12CVV blu	Molla con vomere reversibile blu 550031	32x12	40x6x190	10x38	3,2

MOLLE
Cultivator tines
Feingrubberzinken
Dents pour vibroculteurs
Культиваторные стойки



MOLLA FLEX ALTA 32x12

High S-Tine 32x12
 Lange Kultizinke 32x12
 Dent de vibro longue 32x12
 S-образная стойка длинная 32x12

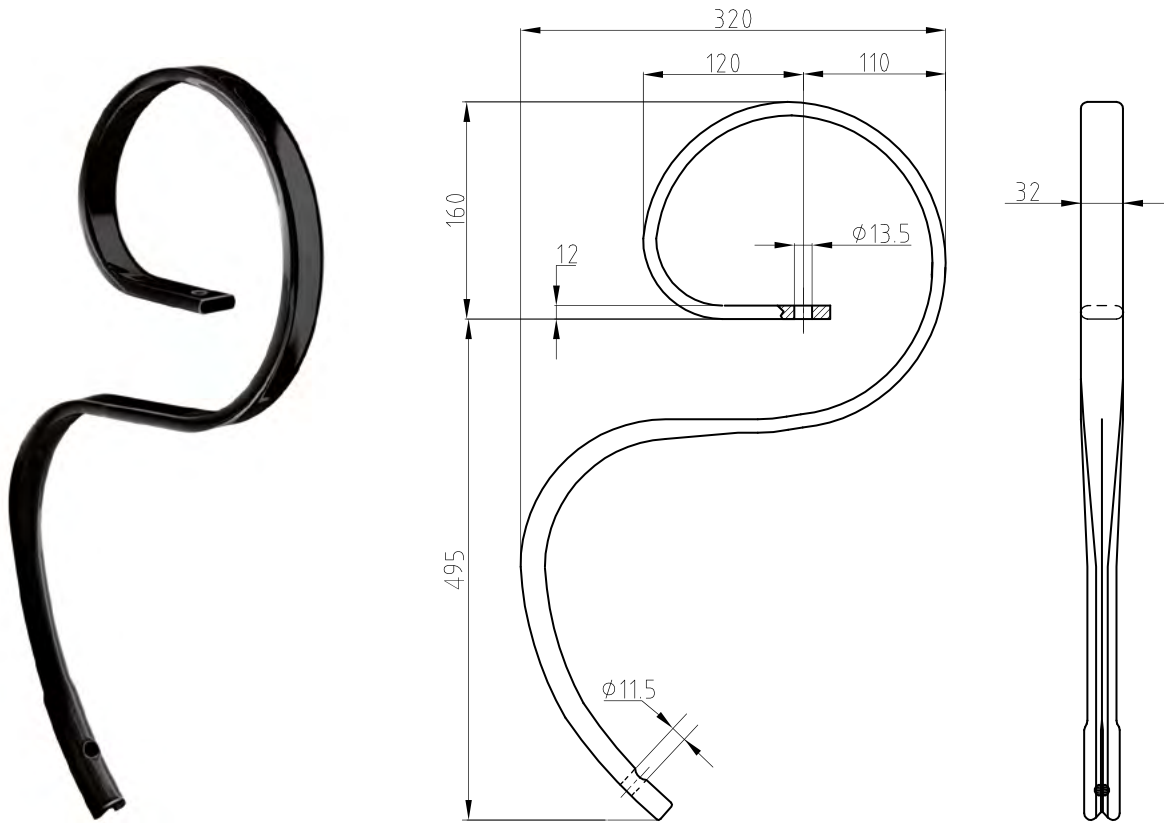

Codice Nr. Ref. Nr. Re. Nr. Ref. Nr. Код №		Quote Dimensions Abmessungen Dimensions Размеры mm	Vomere Point Schar Соч Лана mm	Bullone Bolt Schrauben Boulon Болт	Peso Weight Gewicht Poids Вес gr
F12ASVV	Molla senza vomere	32x12	—	—	3,4
F12ACVV	Molla con vomere reversibile 550001	32x12	40x5x190	10x38	3,65
F12ACVV6	Molla con vomere reversibile 550031	32x12	40x6x190	10x38	3,80
F12ACVV8	Molla con vomere reversibile 550102	32x12	40x8x210	10x38	3,90
F12ACVV105	Molla con vomere a lancia 550027	32x12	105x4	10x38	3,65

Monta il rinforzo RF10ARV

Tutti i modelli sono di nostra produzione e non originali.
 All models are of our manufacture and are not original.
 Alle unsere Landwirtschaftliche erzeugnisse sind unsere produktion und sind nicht original.
 Tous les modèles sont notre production et ne sont pas des produits d'origine.
 Все модели нашего производства и не являются оригинальными.

N.B. Pesi e misure sopra descritti sono puramente indicativi.
 N.B. The above weights and dimensions are given for reference only.
 N.B. Die obengenannten Gewichte und Abmessungen sind richtungsweisend.
 N.B. Les poids et les dimensions indiqués ci-dessus sont donnés à titre indicatif.
 N.B. Указанные вес и размеры, являются ориентировочными.

© La riproduzione
 anche parziale
 del presente catalogo
 è vietata.



MOLLA FLEX TIPO RAU

S-Tine RAU
 Kultizinke RAU
 Dent de vibro RAU
 S-образная стойка RAU

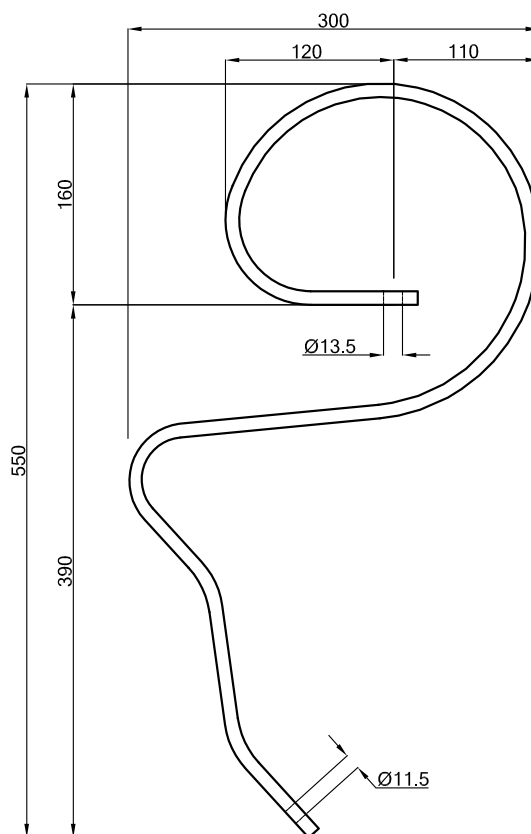

Codice Nr. Ref. Nr. Re. Nr. Ref. Nr. Код №		Quote Dimensions Abmessungen Dimensions Размеры mm	Vomere Point Schar Soc Лана mm	Bullone Bolt Schrauben Boulon Болт	Peso Weight Gewicht Poids Вес gr
FR10SVV	Molla senza vomere	32x10	—	—	2,8
FR10CVV	Molla con vomere reversibile 550030	32x10	40x5x180	10x38	3
FR10CVV6	Molla con vomere reversibile VRFR6	32x10	40x6x180	10x38	3,1
FR12SVV	Molla senza vomere	32x12	—	—	3,2
FR12CVV	Molla con vomere reversibile 550030	32x12	40x5x180	10x38	3,3
FR12CVV6		32x12	40x6x180	10x38	3,4

Monta il rinforzo RF10RVR

MOLLE
Cultivator tines
Feingrubberzinken
Dents pour vibroculteurs
Культиваторные стойки



RINFORZO PER MOLLE FLEX

Stiffening for S-Tine
 Verstärkung für Kultizinken
 Renfort pour dent de vibro
 Подпружинник для S-образной стойки

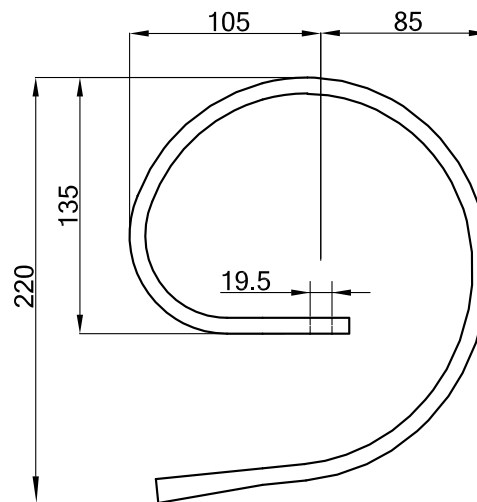

Codice Nr. Ref. Nr. Re. Nr. Ref. Nr. Код №	Quote Dimensions Abmessungen Dimensions Размеры mm	Peso Weight Gewicht Poids Вес gr
RF8V	32x8	1,3
RF10V	32x10	1,6

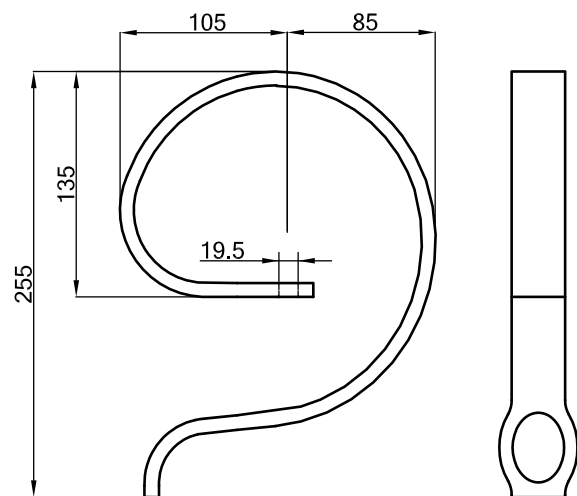

RF8RV	32x8	1,4
RF10RV	32x10	1,6

Tutti i modelli sono di nostra produzione e non originali.
 All models are of our manufacture and are not original.
 Alle unsere Landwirtschaftliche erzeugnisse sind unsere produktion und sind nicht original.
 Tous les modèles sont notre production et ne sont pas des produits d'origine.
 Все модели нашего производства и не являются оригинальными.

N.B. Pesi e misure sopra descritti sono puramente indicativi.
 N.B. The above weights and dimensions are given for reference only.
 N.B. Die obengenannten Gewichte und Abmessungen sind richtungsweisend.
 N.B. Les poids et les dimensions indiqués ci-dessus sont donnés à titre indicatif.
 N.B. Указанные вес и размеры, являются ориентировочными.

© La riproduzione
 anche parziale
 del presente catalogo
 è vietata.

MOLLE
Cultivator tines
Feingrubberzinken
Dents pour vibroculteurs
Культиваторные стойки



Codice Eurozappa Eurozappa Ref. Nr. Eurozappa Re. Nr. Eurozappa Ref. Nr. Код Еврозаппа №	Codice Tecnozappa Tecnozappa Ref. Nr. Tecnozappa Re. Nr. Tecnozappa Ref. Nr. Код Технозаппа №	Sezione Section Abschnitt Section Размеры A x B x C mm	Molla Tine Kulturreggenzinken Dents pour vibroculteur Культиваторная стойка mm	Bullone Bolt Schrauben Boulon Болт	Peso Weight Gewicht Poids Вес kg
--	---	---	---	--	---

VOMERE REVERSIBILE PER FLEX

Reversible point for S-Tine
 Umgekehrte Schare für Kultizinken
 Soc réversible pour dent de vibro
 Двусторонняя лапа для S-образной стойки

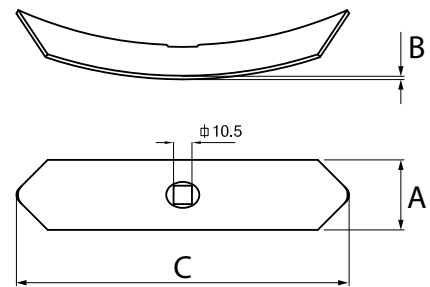

550030	VRFR	40x5x180	32x10 / 32x12	10x38	0,260
VRFR6		40x6x180	32x10 / 32x12	10x38	0,320
550001	VRF5	40x5x190	32x10 / 32x12	10x38	0,270
550031	VRF6	40x6x190	32x10 / 32x12	10x38	0,310
550034	VRF6L	40x6x210	32x10 / 32x12	10x38	0,350
550102	VRF8	40x8x210	32x10 / 32x12	10x38	0,540

VOMERE A ZAMPA D'OCA

Duck foot point
 Gansgusschar
 Soc patte d'oie
 Культиваторная лапа

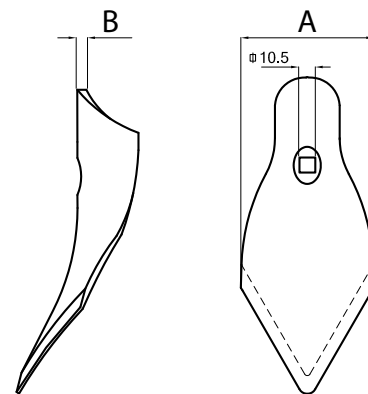

550018	VZO	70x4	32x10 / 32x12 / 45x12	10x38	0,230
550057	VZO6	70x6	32x10 / 32x12 / 45x12	10x38	0,250

MOLLE
Cultivator tines
Feingrubberzinken
Dents pour vibroculteurs
Культиваторные стойки



Codice Eurozappa
Eurozappa Ref. Nr.
Eurozappa Re. Nr.
Eurozappa Ref. Nr.
Код Еврозаппа №

Sezione
Section
Abschnitt
Section
Размеры
A x B mm

Molla
Tine
Kultureggenzinken
Dents pour vibroculteur
Культиваторная стойка
mm

Bullone
Bolt
Schrauben
Boulon
Болт

Peso
Weight
Gewicht
Poids
Вес
kg

VOMERE A LANCIA

Duck foot point
Breitschare
Сос coeur
Лапа стрельчатая

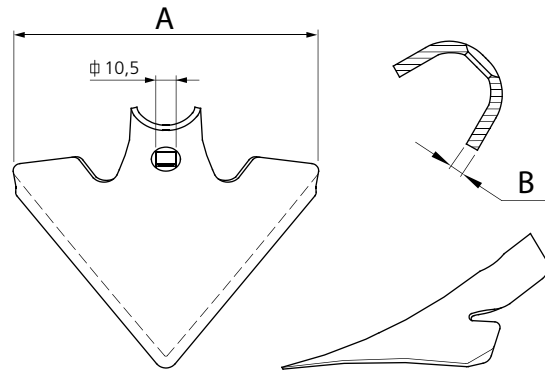

550027	105×4	32×10 / 32×12	10×38	0,230
550028	150×4	32×10 / 32×12 / 45×12	10×38	0,400

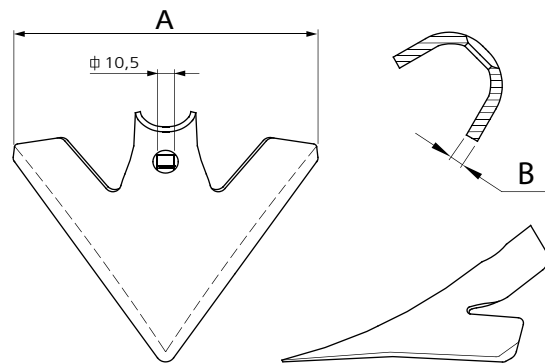

550017	175×4	32×10 / 32×12 / 45×12	10×38	0,450
550151	200×4	32×10 / 32×12 / 45×12	10×38	0,430
550152	250×4	32×10 / 32×12 / 45×12	10×38	0,640

Tutti i modelli sono di nostra produzione e non originali.
All models are of our manufacture and are not original.
Alle unsere Landwirtschaftliche erzeugnisse sind unsere produktion und sind nicht original.
Tous les modèles sont notre production et ne sont pas des produits d'origine.
Все модели нашего производства и не являются оригинальными.

N.B. Pesi e misure sopra descritti sono puramente indicativi.
N.B. The above weights and dimensions are given for reference only.
N.B. Die obengenannten Gewichte und Abmessungen sind richtungsweisend.
N.B. Les poids et les dimensions indiqués ci-dessus sont donnés à titre indicatif.
N.B. Указанные вес и размеры, являются ориентировочными.

© La riproduzione
anche parziale
del presente catalogo
è vietata.



STAFFA D'ATTACCO 50x6
PER MOLLE FLEX

Clamp for S-Tine (50x6)
 Stütze für Kultizinken (50x6)
 Bride pour dents de vibro (50x6)
 Стремя для S-образной стойки (50x6)

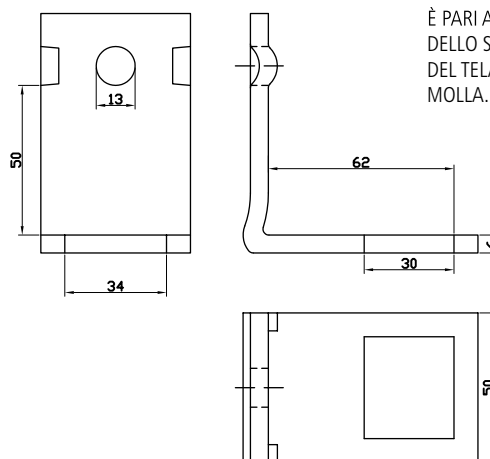
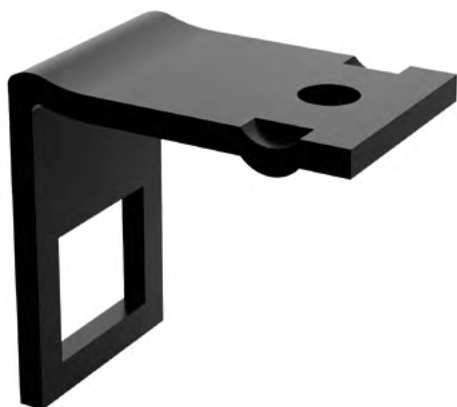

L'ALTEZZA (H=22)
 È PARI ALLA SOMMA
 DELLO SPESSORE
 DEL TELAIO E DELLA
 MOLLA.

EXAMPLE: AF662

Codice Nr. Ref. Nr. Re. Nr. Ref. Nr. Код №	Altezza High Grosse Hauteur Высота mm	Telaio Frame Rahmen Chassis Рама	Molla Spring Zinken Dent Стойка	Rinforzo Auxiliary Verstärkung Renfort Подпружинник	Peso Weight Gewicht Poids Вес gr
MONOLAMA / SINGLE SPRING / EINBLATT / MONOLAME / ОДНОПРОФИЛЬНАЯ					
AF622	22	50x12	32x10	—	250
AF625	25	50x15	32x10	—	250
AF624	24	50x12	32x12	—	250
AF627	27	50x15	32x12	—	250
AF662	62	50x50	32x12	—	330
AF660	60	50x50	32x10	—	330
BILAMA / DOUBLE SPRING / DOPPELBLATT / DEUX LAMES / ДВУХПРОФИЛЬНАЯ					
AF632	32	50x12	32x10	32x10	260
AF635	35	50x15	32x10	32x10	260
AF634	34	50x12	32x12	32x10	260
AF637	37	50x15	32x12	32x10	260

MOLLE
Cultivator tines
Feingrubberzinken
Dents pour vibroculteurs
Культиваторные стойки



STAFFA D'ATTACCO 50x8
PER MOLLE FLEX

Clamp for S-Tines (50x8)
 Stütze für Kultizinken (50x8)
 Bride pour dents de vibro (50x8)
 Стремя для S-образной стойки (50x8)

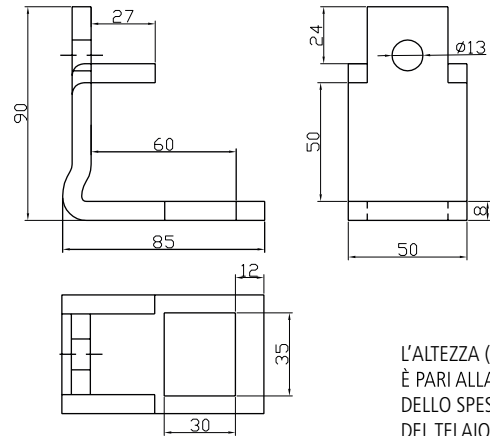
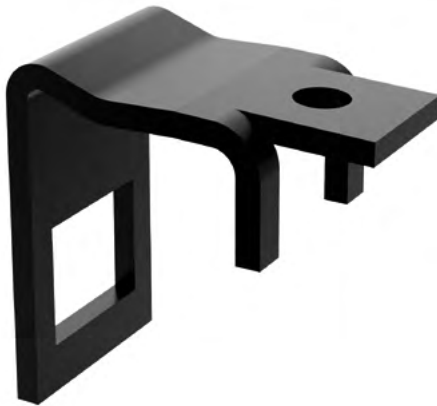

EXAMPLE: AF860

L'ALTEZZA (H=35)
 È PARI ALLA SOMMA
 DELLO SPESSORE
 DEL TELAIO,
 DELLA MOLLA
 E DEL RINFORZO.

Codice Nr. Ref. Nr. Re. Nr. Ref. Nr. Код №	Altezza High Grosse Hauteu Высота mm	Telaio Frame Rahmen Chassis Рама	Molla Spring Zinken Dent Стойка	Rinforzo Auxiliary Verstärkung Renfort Подпругинник	Peso Weight Gewicht Poids Вес gr
MONOLAMA / SINGLE SPRING / EINZELBLATT / MONOLAME / ОДНОПРОФИЛЬНАЯ					
AF822	22	50x12	32x10	—	300
AF825	25	50x15	32x10	—	300
AF824	24	50x12	32x12	—	300
AF827	27	50x15	32x12	—	300
AF850	50	40x40	32x10	—	440
AF862	62	50x50	32x12	—	440
AF860	60	50x50	32x10	—	440
BILAMA / DOUBLE SPRING / DOPPELBLATT / DEUX LAMES / ДВУХПРОФИЛЬНАЯ					
AF832	32	50x12	32x10	32x10	320
AF835	35	50x15	32x10	32x10	320
AF834	34	50x12	32x12	32x10	320
AF837	37	50x15	32x12	32x10	320
AF860	60	40x40	32x10	32x10	440
AF872	72	50x50	32x12	32x10	450

Tutti i modelli sono di nostra produzione e non originali.
 All models are of our manufacture and are not original.
 Alle unsere Landwirtschaftliche erzeugnisse sind unsere produktion und sind nicht original.
 Tous les modèles sont notre production et ne sont pas des produits d'origine.
 Все модели нашего производства и не являются оригинальными.

N.B. Pesi e misure sopra descritti sono puramente indicativi.
 N.B. The above weights and dimensions are given for reference only.
 N.B. Die obengenannten Gewichte und Abmessungen sind richtungsweisend.
 N.B. Les poids et les dimensions indiqués ci-dessus sont donnés à titre indicatif.
 N.B. Указанные вес и размеры, являются ориентировочными.

© La riproduzione
 anche parziale
 del presente catalogo
 è vietata.



**STAFFA D'ATTACCO TIPO AMERICA
 PER MOLLE FLEX (50x6 / 50x8)**

Clamp american type for S-Tines (50x6 / 50x8)
 AMERICA Typ Stütze für Kultizinken (50x6 / 50x8)
 Bride type america pour dents de vibro (50x6 / 50x8)
 Стремя американского типа для S-образных стоек (50x6 / 50x8)

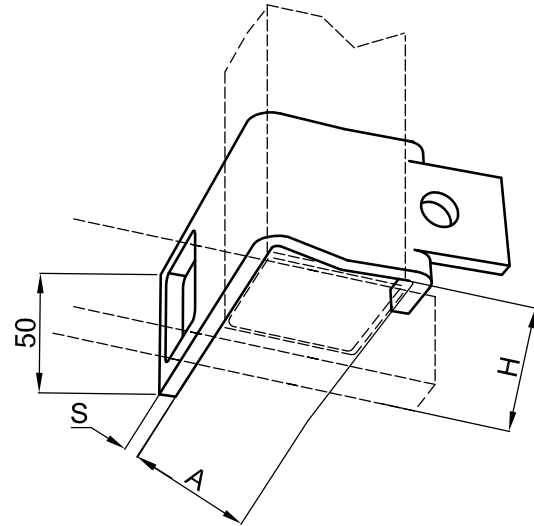
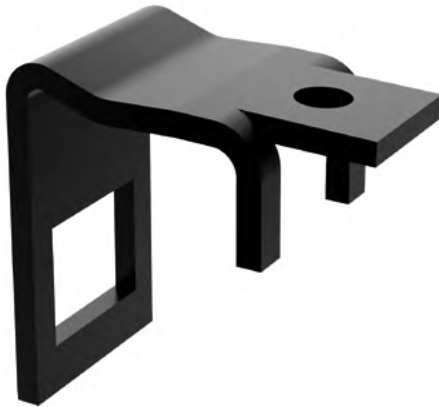

Codice Nr. Ref. Nr. Re. Nr. Ref. Nr. Код №	S mm	A	H	Telaio Frame Rahmen Chassis Пама	Flex Flex Flex Flex mm	Peso Weigh Gewicht Poids Вес gr
AF6A1	6	2"	2" + 10 mm	2" x 2"	32x10	300
AF6A2	6	2"	2" + 12 mm	2" x 2"	32x12	350
AF6A3	6	2½"	2½" + 10 mm	2½" x 2½"	32x10	400
AF6A4	6	2½"	2½" + 12 mm	2½" x 2½"	32x12	450
AF8A1	8	2"	2" + 10 mm	2" x 2"	32x10	400
AF8A2	8	2"	2" + 12 mm	2" x 2"	32x12	450
AF8A3	8	2½"	2½" + 10 mm	2½" x 2½"	32x10	500
AF8A4	8	2½"	2½" + 12 mm	2½" x 2½"	32x12	550

MOLLE
Cultivator tines
Feingrubberzinken
Dents pour vibroculteurs
Культиваторные стойки



MOLLA FLEX DIRITTA 32×10

Straight S-Tine 32×10
 Gerade Kultizinke 32×10
 Dent de vibroculteur droite 32×10
 Стойка S-образная прямая 32×10

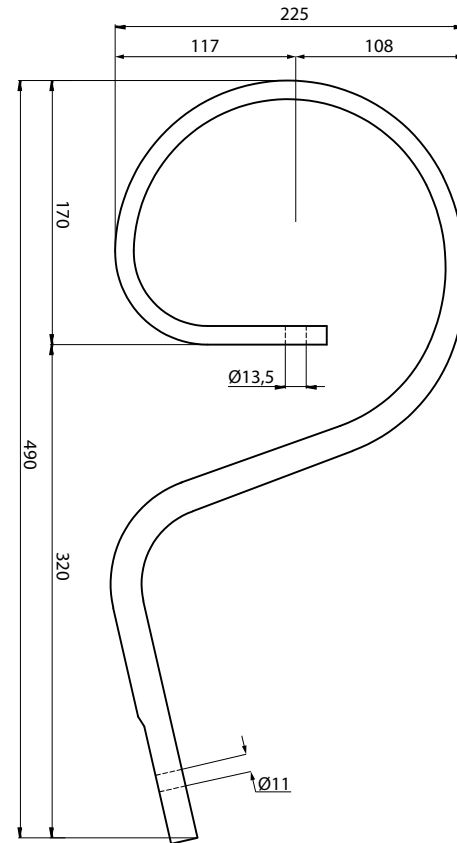

Codice Nr. Ref. Nr. Re. Nr. Ref. Nr. Код №		Quote Dimensions Abmessungen Dimensions Размеры mm	Vomere Point Schar Soc Лана mm	Bullone Bolt Schrauben Boulon Болт	Peso Weight Gewicht Poids Вес gr
F10DSVV	Molla senza vomere	32×10	—	—	2,3
F10DCVV	Molla con vomere reversibile 550135	32×10	40×5×135	10×38	2,5
F10DCVV6	Molla con vomere reversibile 550136	32×10	40×6×135	10×38	2,8

È possibile montare vomeri da 40×6 con lunghezze di 200, 210, 215 mm.

È possibile variare a richiesta l'altezza del sottotesta e l'inclinazione del gambo.

Tutti i modelli sono di nostra produzione e non originali.
 All models are of our manufacture and are not original.
 Alle unsere Landwirtschaftliche erzeugnisse sind unsere produktion und sind nicht original.
 Tous les modèles sont notre production et ne sont pas des produits d'origine.
 Все модели нашего производства и не являются оригинальными.

N.B. Pesi e misure sopra descritti sono puramente indicativi.
 N.B. The above weights and dimensions are given for reference only.
 N.B. Die obengenannten Gewichte und Abmessungen sind richtungsweisend.
 N.B. Les poids et les dimensions indiqués ci-dessus sont donnés à titre indicatif.
 N.B. Указанные вес и размеры, являются ориентировочными.

© La riproduzione
 anche parziale
 del presente catalogo
 è vietata.



MOLLA FLEX DIRITTA 32×12

Straight S-Tine 32×12
 Gerade Kultizinke 32×12
 Dent de vibroculteur droite 32×12
 Стойка S-образная прямая 32×12

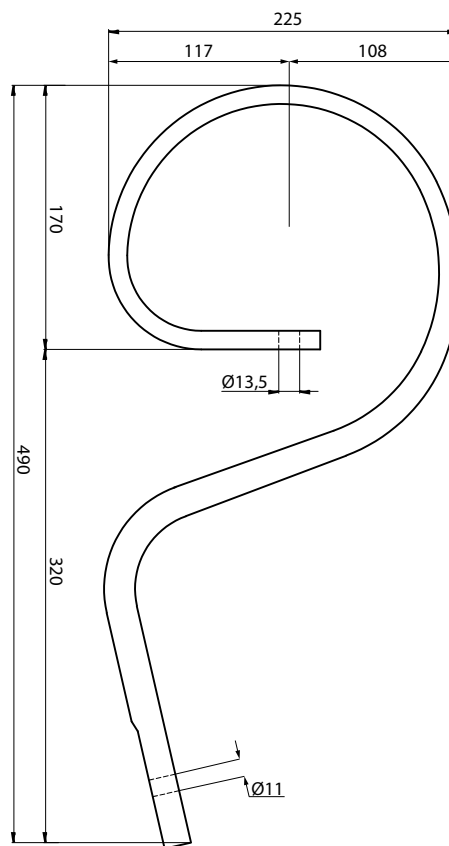

Codice Nr. Ref. Nr. Re. Nr. Ref. Nr. Код №		Quote Dimensions Abmessungen Dimensions Размеры mm	Vomere Point Schar Soc Лана mm	Bullone Bolt Schrauben Boulon Болт	Peso Weight Gewicht Poids Вес gr
F12DSVV	Molla senza vomere	32×12	—	—	2,9
F12DCVV	Molla con vomere reversibile 550122	32×12	40×5×195	10×38	3,15
F12DCVV6	Molla con vomere reversibile VRFD6	32×12	40×6×195	10×38	3,85

È possibile montare vomeri da 40×6 con lunghezze di 200, 210, 215 mm.

È possibile variare a richiesta l'altezza del sottotesta e l'inclinazione del gambo.



FLEX GERMINATOR 32×10

Straight S-Tine Germinator (32×10)
 Gerade Kultizinke Germinator (32×10)
 Dent de vibroculteur droite Germinator (32×10)
 Стойка S-образная Герминатор (32×10)

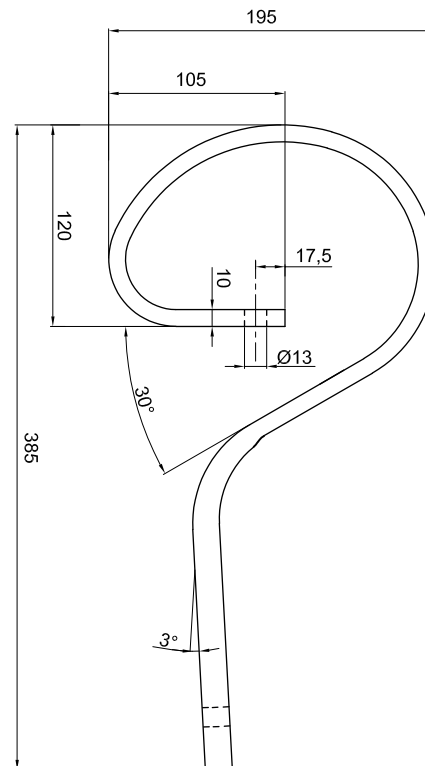

Codice Nr. Ref. Nr. Re. Nr. Ref. Nr. Код №		Quote Dimensions Abmessungen Dimensions Размеры mm	Vomere Point Schar Soc Лана mm	Bullone Bolt Schrauben Boulon Болт	Peso Weight Gewicht Poids Вес gr
F10D-SVV	Molla senza vomere	32×10	—	—	2,3
F10D-SCVV	Molla con vomere reversibile 550135	32×10	40×5×135	10×38	2,5
F10D-SCVV6	Molla con vomere reversibile 550136	32×10	40×6×135	10×38	2,8
F10D-SCVV195	Molla con vomere reversibile 550122	32×10	40×5×195	10×38	3,5

Tutti i modelli sono di nostra produzione e non originali.
 All models are of our manufacture and are not original.
 Alle unsere Landwirtschaftliche erzeugnisse sind unsere produktion und sind nicht original.
 Tous les modèles sont notre production et ne sont pas des produits d'origine.
 Все модели нашего производства и не являются оригинальными.

N.B. Pesi e misure sopra descritti sono puramente indicativi.
 N.B. The above weights and dimensions are given for reference only.
 N.B. Die obengenannten Gewichte und Abmessungen sind richtungsweisend.
 N.B. Les poids et les dimensions indiqués ci-dessus sont donnés à titre indicatif.
 N.B. Указанные вес и размеры, являются ориентировочными.

© La riproduzione anche parziale del presente catalogo è vietata.



FLEX JACKPOT 32×10

Straight S-Tine Jackpot (32×10)
 Gerade Kultizinke Jackpot (32×10)
 Dent de vibroculteur droite Jackpot (32×10)
 Стойка S-образная Jackpot (32×10)

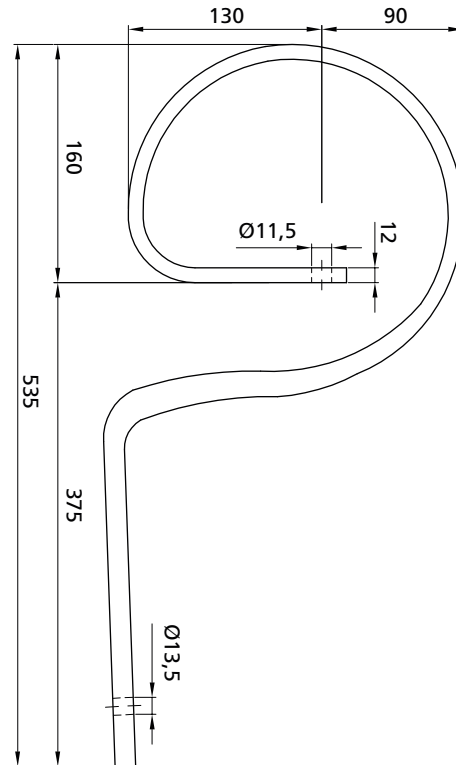

Codice Nr. Ref. Nr. Re. Nr. Ref. Nr. Код №		Quote Dimensions Abmessungen Dimensions Размеры mm	Vomere Point Schar Soc Лана mm	Bullone Bolt Schrauben Boulon Болт	Peso Weight Gewicht Poids Вес gr
F12DJSVV	Molla senza vomere	32×12	—	—	2,9
F12DJCVV	Molla con vomere reversibile 550122	32×12	40×5×195	10×38	3,2

MOLLE
Cultivator tines
Feingrubberzinken
Dents pour vibroculteurs
Культиваторные стойки



Codice Eurozappa Eurozappa Ref. Nr. Eurozappa Re. Nr. Eurozappa Ref. Nr. Код Еврозатпа №	Sezione Section Abschnitt Section Размеры A x B x C mm	Molla Tine Kulturreggenzinken Dents pour vibroculteur Культиваторная стойка mm	Bullone Bolt Schrauben Boulon Болт	Peso Weight Gewicht Poids Вес kg
--	---	---	--	---

**VOMERI REVERSIBILI PER FLEX
DIRITTA, GERMINATOR E JACKPOT**

Reversible point for straight S-Tine, Germinator and Jackpot
Umgekehrte Schare für gerade Kultizinke, Germinator und Jackpot
Soc réversible pour dent de vibro droite, Germinator et Jackpot
Долото для прямой S-образной стойки, герминатор и Jackpot

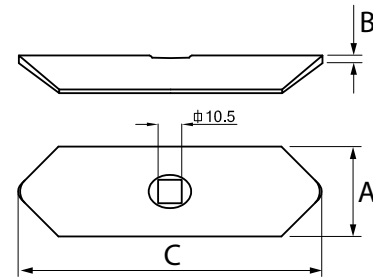

550135	VGCAN	40x5x135	32x10	10x38	0,200
550136	VGCAN6	40x6x135	32x10	10x38	0,210

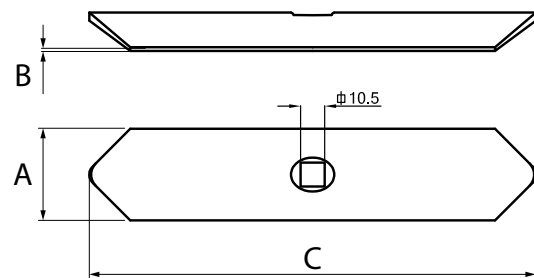

550122	VRFD	40x5x195	32x12	10x38	0,280
VRFD6		40x6x195	32x12	10x38	0,320

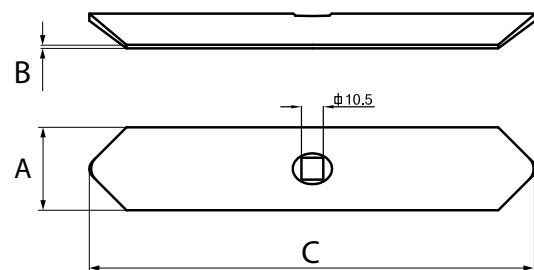

VRFD200		40x6x200	32x10 / 32x12	10x38	0,360
550185	VRFD210	40x6x210	32x10 / 32x12	10x38	0,380
VRFD215		40x6x215	32x10 / 32x12	10x38	0,400

Tutti i modelli sono di nostra produzione e non originali.
All models are of our manufacture and are not original.
Alle unsere Landwirtschaftliche erzeugnisse sind unsere produktion und sind nicht original.
Tous les modèles sont notre production et ne sont pas des produits d'origine.
Все модели нашего производства и не являются оригинальными.

N.B. Pesi e misure sopra descritti sono puramente indicativi.
N.B. The above weights and dimensions are given for reference only.
N.B. Die obengenannten Gewichte und Abmessungen sind richtungsweisend.
N.B. Les poids et les dimensions indiqués ci-dessus sont donnés à titre indicatif.
N.B. Указанные вес и размеры, являются ориентировочными.

© La riproduzione
anche parziale
del presente catalogo
è vietata.



MOLLA SPIETRAMENTO 32x12

Stoning S-Tine 32x12
 Felsabtrag Kultizinke 32x12
 Dent de vibroculteur drainage 32x12
 S-образная стойка рыхлитель 32X12

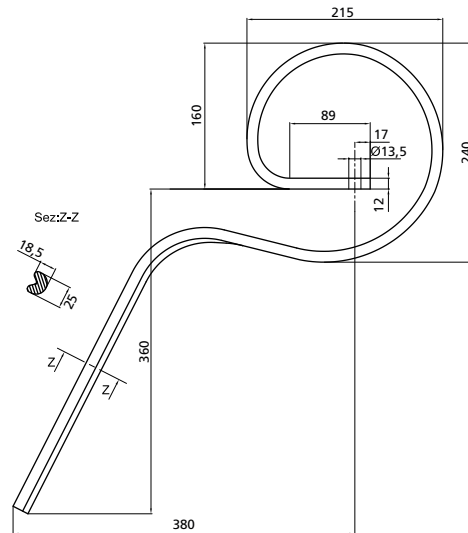

Codice Nr. Ref. Nr. Re. Nr. Ref. Nr. Код №	Quote Dimensions Abmessungen Dimensions Размеры mm	Vomere Point Schar Soc Лана mm	Bullone Bolt Schrauben Boulon Болт	Peso Weight Gewicht Poids Bec gr
F12SPTRK	Molla senza vomere	32x12	—	3,17

RINFORZO PER
MOLLA SPIETRAMENTO

Stiffening for stoning S-Tine 32x12
 Verstärkung für felsabtrag Kultizinken 32x12
 Renfort pour dent vibroculteur drainage 32x12
 Подпружинник для S-образной стойки рыхлитель 32X12

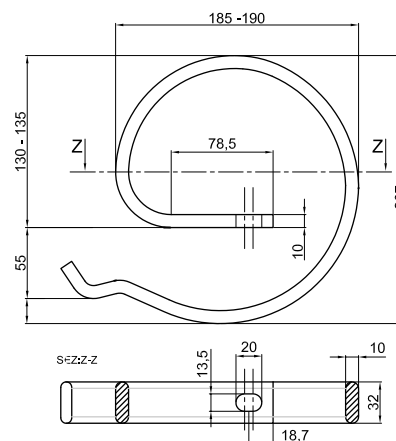

Codice Nr. Ref. Nr. Re. Nr. Ref. Nr. Код №	Quote Dimensions Abmessungen Dimensions Размеры mm	Peso Weight Gewicht Poids Bec gr
RF10SPTRK	32x10	1,6

MOLLE
Cultivator tines
Feingrubberzinken
Dents pour vibroculteurs
Культиваторные стойки



MOLLA FLEX 45x10

S-Tine 45x12
 Kultizinke 45x12
 Dent de vibroculteur 45x12
 S-образная стойка 45x12

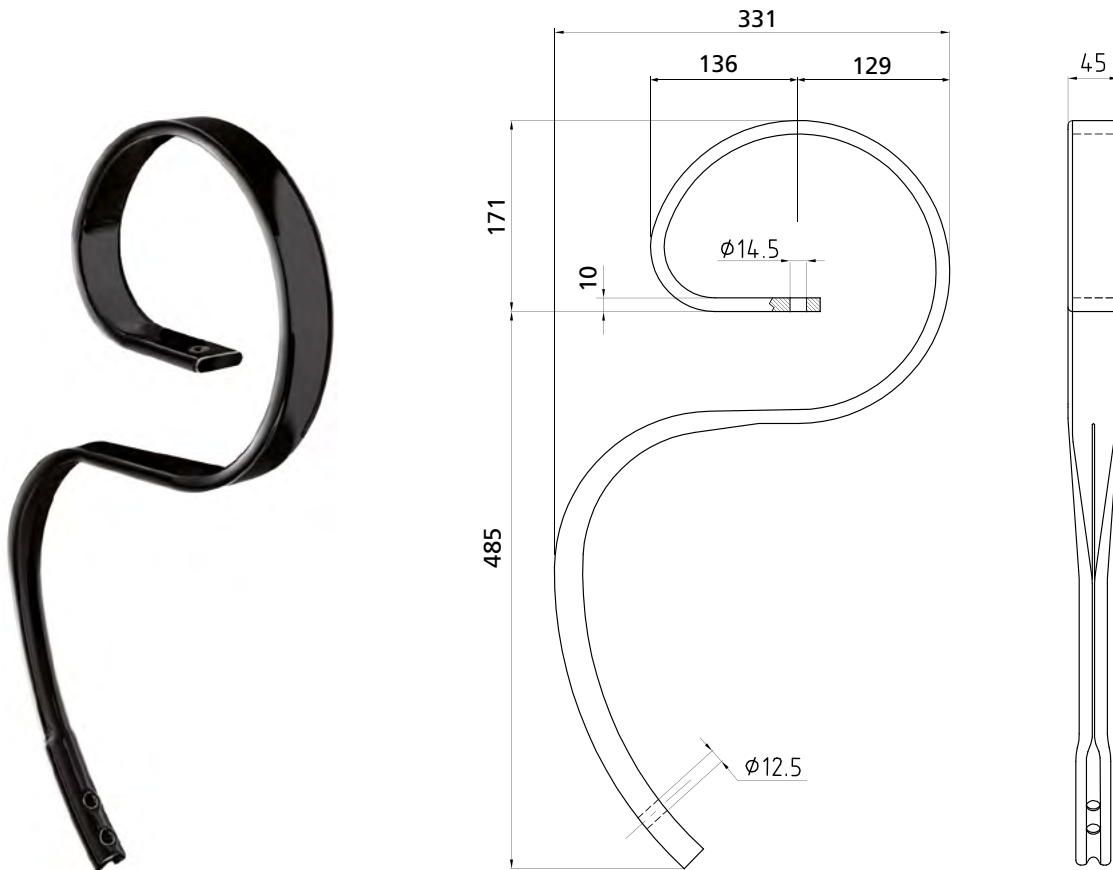

Codice Nr. Ref. Nr. Re. Nr. Ref. Nr. Код №		Quote Dimensions Abmessungen Dimensions Размеры mm	Vomere Point Schar Soc Лана mm	Bullone Bolt Schrauben Boulon Болт	Peso Weight Gewicht Poids Вес gr
F4510SVV	Molla senza vomere	45x10	—	—	4,60

Tutti i modelli sono di nostra produzione e non originali.
 All models are of our manufacture and are not original.
 Alle unsere Landwirtschaftliche erzeugnisse sind unsere produktion und sind nicht original.
 Tous les modèles sont notre production et ne sont pas des produits d'origine.
 Все модели нашего производства и не являются оригинальными.

N.B. Pesi e misure sopra descritti sono puramente indicativi.
 N.B. The above weights and dimensions are given for reference only.
 N.B. Die obengenannten Gewichte und Abmessungen sind richtungsweisend.
 N.B. Les poids et les dimensions indiqués ci-dessus sont donnés à titre indicatif.
 N.B. Указанные вес и размеры, являются ориентировочными.

© La riproduzione
 anche parziale
 del presente catalogo
 è vietata.



MOLLA FLEX 45x12

S-Tine 45x12
 Kultizinke 45x12
 Dent de vibroculteur 45x12
 S-образная стойка 45x12

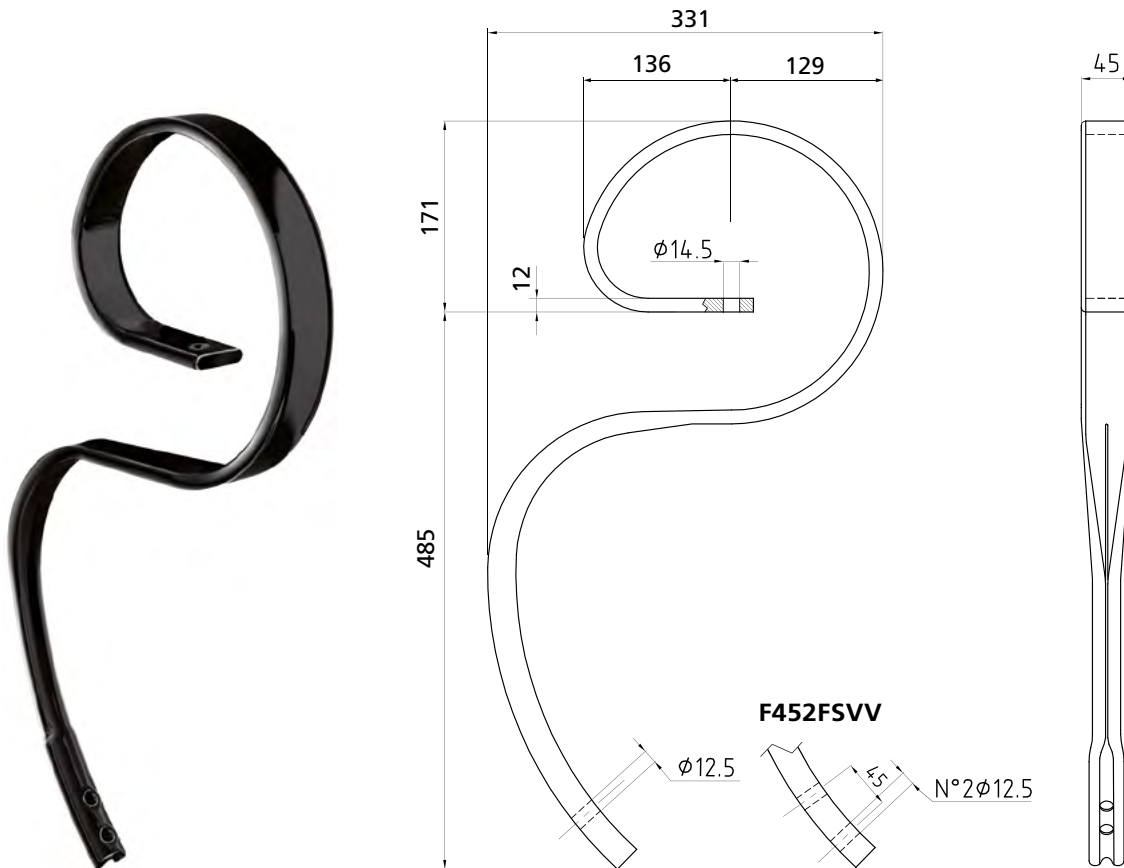

Codice Nr. Ref. Nr. Re. Nr. Ref. Nr. Код №		Quote Dimensions Abmessungen Dimensions Размеры mm	Vomere Point Schar Soc Лана mm	Bullone Bolt Schrauben Bouton Болт	Peso Weight Gewicht Poids Вес gr
F45SVV	Molla senza vomere	45x12	—	—	5
F45CVV	Molla con vomere reversibile 550067	45x12	60x6x268	10x45	5,6
F45CVVZO	Molla con vomere zampa d'oca 550018	45x12	70x4	10x45	5,25
F45CVV105	Molla con vomere a lancia 550027	45x12	105x4	10x45	5,25
F45CVV150	Molla con vomere a lancia 550028	45x12	150x4	10x45	5,45
F45CVV175	Molla con vomere a lancia 550017	45x12	175x4	10x45	5,5
F452FSVV	Molla senza vomere (Nr. 2 fori)	45x12	—	—	5

MOLLE
Cultivator tines
Feingrubberzinken
Dents pour vibroculteurs
Культиваторные стойки



RINFORZO PER MOLLA FLEX
45x12

Stiffening for S-Tine 45x12
 Verstärkung für Kultizinken 45x12
 Renfort pour dent de vibro 45x12
 Подпружинник для S-образной стойки 45x12

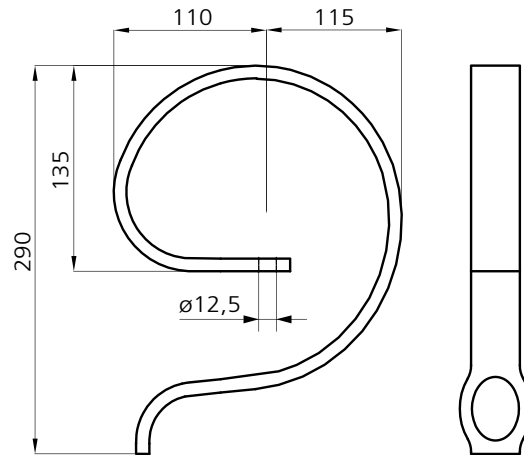

Codice Nr. Ref. Nr. Re. Nr. Ref. Nr. Код №	Quote Dimensions Abmessungen Dimensions Размеры mm		Peso Weight Gewicht Poids Bec gr
RF45V	45x10		2,58

VOMERE REVERSIBILE
PER FLEX 45x12

Reversible point for S-Tine 45x12
 Umgekehrte Schare für Kultizinke 45x12
 Soc réversible pour dent de vibro 45x12
 Двусторонняя лапа для S-образной стойки 45x12

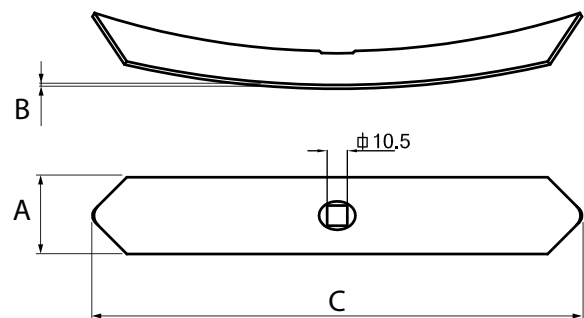
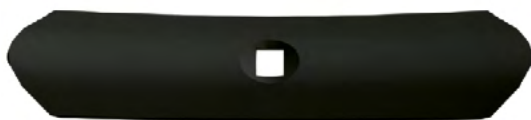

Codice Eurozappa Eurozappa Ref. Nr. Eurozappa Re. Nr. Eurozappa Ref. Nr. Код Еврозатпа №	Sezione Section Abschnitt Section Размеры A x B x C mm	Molla Tine Kultureggenzinken Dents pour vibroculteur Культиваторная стойка mm	Bullone Bolt Schrauben Boulon Болт	Peso Weight Gewicht Poids Bec kg
550067	60x6x268	45x12	10x45	0,660

Tutti i modelli sono di nostra produzione e non originali.
 All models are of our manufacture and are not original.
 Alle unsere Landwirtschaftliche erzeugnisse sind unsere produktion und sind nicht original.
 Tous les modèles sont notre production et ne sont pas des produits d'origine.
 Все модели нашего производства и не являются оригинальными.

N.B. Pesi e misure sopra descritti sono puramente indicativi.
 N.B. The above weights and dimensions are given for reference only.
 N.B. Die obengenannten Gewichte und Abmessungen sind richtungsweisend.
 N.B. Les poids et les dimensions indiqués ci-dessus sont donnés à titre indicatif.
 N.B. Указанные вес и размеры, являются ориентировочными.

© La riproduzione
 anche parziale
 del presente catalogo
 è vietata.



STAFFA D'ATTACCO 70x10
PER MOLLE FLEX 45x12

Clamp for S-Tines 45x12 (70x10)
 Stütze für Kultizinken 45x12 (70x10)
 Bride pour dents de vibro 45x12 (70x10)
 Стремя для S-образной стойки 45x12 (70x10)



AF4512

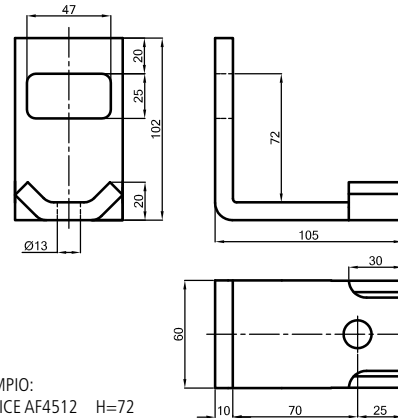

ESEMPIO:
 CODICE AF4512 H=72

Codice Nr. Ref. Nr. Re. Nr. Ref. Nr. Код №	Altezza High Grosse Hauteur Высота mm	Telaio Frame Rahmen Chassis Рама	Molla Spring Zinken Dent Стойка	Rinforzo Auxiliary Verstärkung Renfort Подпружинник	Peso Weight Gewicht Poids Вес gr
--	--	--	---	---	---

MONOLAMA / SINGLE SPRING / EINBLATT / MONOLAME / ОДНОПРОФИЛЬНАЯ

AF451250	62	50x50	45x12	—	850
AF4512	72	60x60	45x12	—	900
AF451270	82	70x70	45x12	—	950



AF4512R

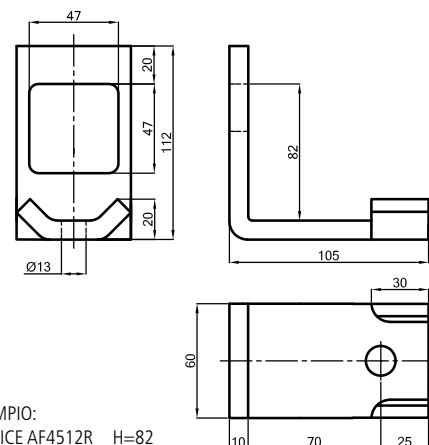

ESEMPIO:
 CODICE AF4512R H=82

BILAMA / DOUBLE SPRING / DOPPELBLATT / DEUX LAMES / ДВУХПРОФИЛЬНАЯ

AF4512R50	72	50x50	45x12	45x10	920
AF4512R	82	60x60	45x12	45x10	970

MOLLE
Cultivator tines
Feingrubberzinken
Dents pour vibroculteurs
Культиваторные стойки



MOLLA FLEX 50x12 A 2 FORI

S-Tine 50x12 with 2 holes
 Kultizinke 50x12 mit 2 Löcher
 Dent de vibro 50x12 à 2 trous
 S-образная стойка 50x12 / 2 отверстия

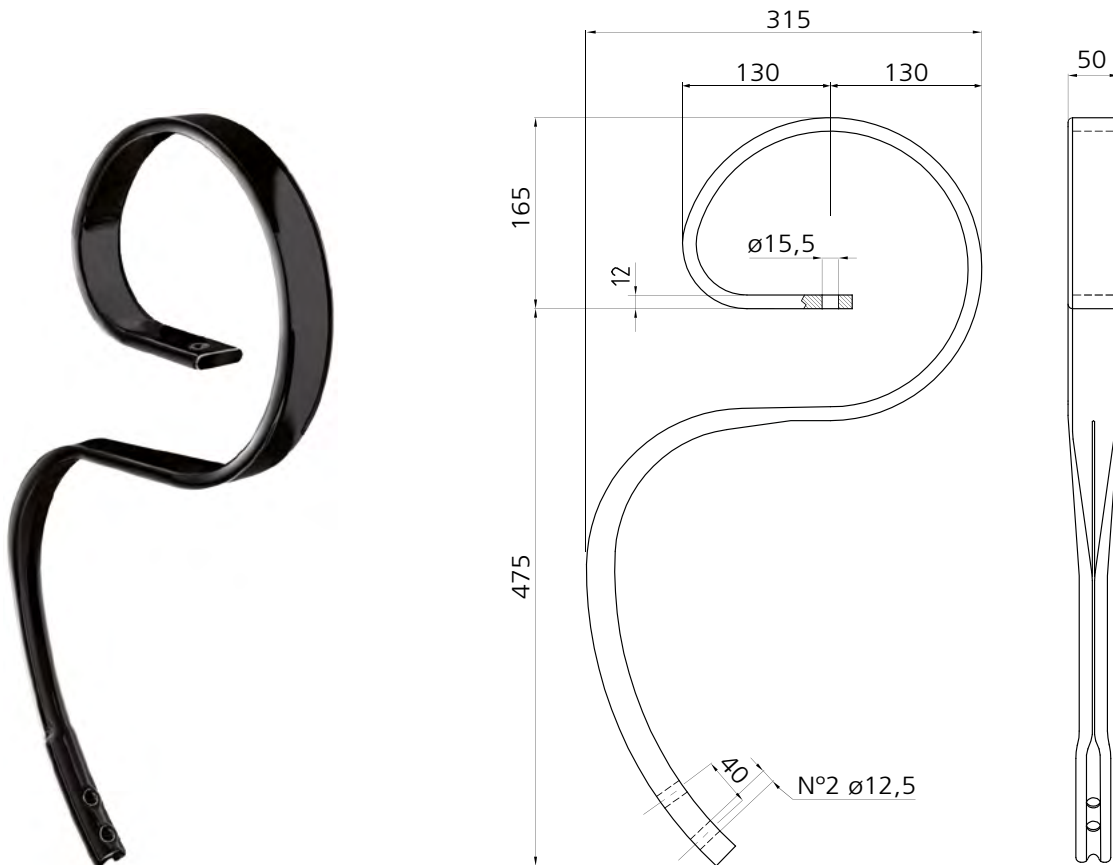

Codice Nr. Ref. Nr. Re. Nr. Ref. Nr. Код №		Quote Dimensions Abmessungen Dimensions Размеры mm	Vomere Point Schar Soc Лана mm	Interasse Center distance Achsenabstand Entraxe Расстояние	Peso Weight Gewicht Poids Вес gr
F50SVV	Molla senza vomere	50x12	—	40	6,1

Tutti i modelli sono di nostra produzione e non originali.
 All models are of our manufacture and are not original.
 Alle unsere Landwirtschaftliche erzeugnisse sind unsere produktion und sind nicht original.
 Tous les modèles sont notre production et ne sont pas des produits d'origine.
 Все модели нашего производства и не являются оригинальными.

N.B. Pesi e misure sopra descritti sono puramente indicativi.
 N.B. The above weights and dimensions are given for reference only.
 N.B. Die obengenannten Gewichte und Abmessungen sind richtungweisend.
 N.B. Les poids et les dimensions indiqués ci-dessus sont donnés à titre indicatif.
 N.B. Указанные вес и размеры, являются ориентировочными.

© La riproduzione anche parziale del presente catalogo è vietata.



STAFFA D'ATTACCO 80x6
PER FLEX 50x12

Clamp 80x6 for S-Tines 50x12
 Stütze 80x6 für Kultizinken 50x12
 Bride 80x6 pour dents de vibro 50x12
 umgekehrte Schare für gerade Kultizinke стойки 50x12

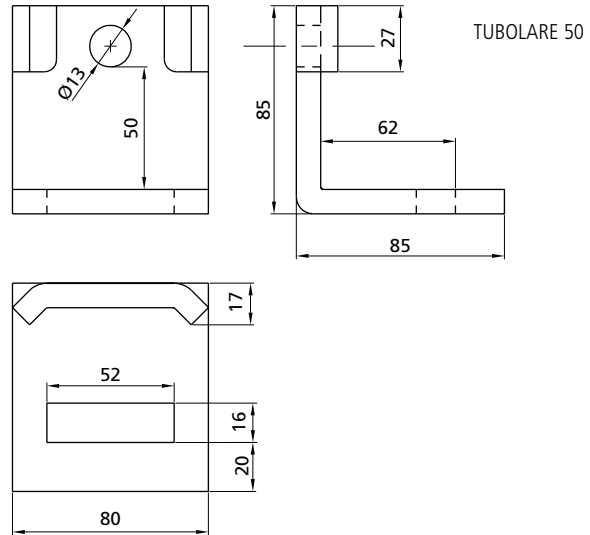
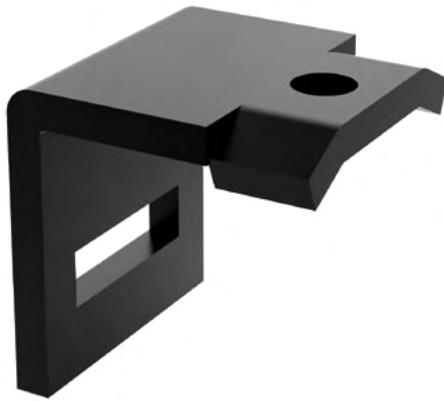

Codice Nr. Ref. Nr. Re. Nr. Ref. Nr. Код №	Altezza High Grosse Hauteur Высота mm	Telaio Frame Rahmen Chassis Рама	Molla Spring Zinken Dent Стойка	Rinforzo Auxiliary Verstärkung Renfort Подпружинник	Peso Weigh Gewicht Poids Вес gr
AF50	62	50x50	50x12	—	0,485

VOMERE REVERSIBILE
PER FLEX 50x12

Reversible point for S-Tine 50x12
 Umgekehrte Schare für gerade Kultizinke 50x12
 Soc réversible pour dent de vibro 50x12
 Двусторонняя лапа для S-образной стойки 50x12

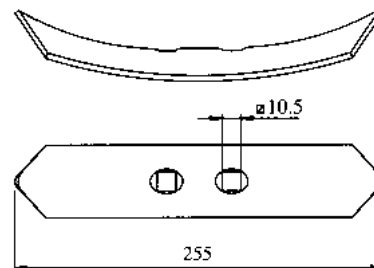

Codice Eurozappa Eurozappa Ref. Nr. Eurozappa Re. Nr. Eurozappa Ref. Nr. Код Еврозатпа №	Sezione Section Abschnitt Section Размеры A x B x C mm	Molla Tine Kulturreggenzinken Dents pour vibroculteur Культиваторная стойка mm	Interasse Center distance Achsenabstand Entraxe Расстояние Ø - Ø	Bullone Bolt Schrauben Boulon Болт	Peso Weight Gewicht Poids Вес kg
V5012	50x6x255	50x12	40	10x45	0,680

MOLLE
Cultivator tines
Feingrubberzinken
Dents pour vibroculteurs
Культиваторные стойки



MOLLA FLEX 65x12

S-Tine 65x12
 Kultizinke 65x12
 Dent de vibro 65x12
 S-образная стойка 65x12

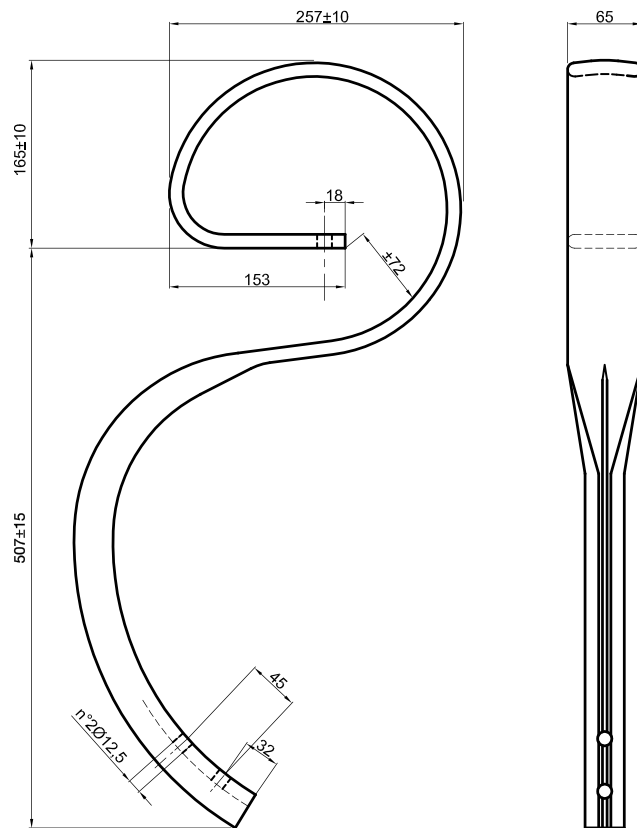

Codice Nr. Ref. Nr. Re. Nr. Ref. Nr. Код №		Quote Dimensions Abmessungen Dimensions Размеры mm	Vomere Point Schar Soc Лана mm	Interasse Center distance Achsenabstand Entraxe Расстояние ∅ - ∅	Bullone Bolt Schrauben Boulon Болт	Peso Weight Gewicht Poids Вес kg
F65SVV	Molla senza vomere	65x12	—	45	—	7,5

Tutti i modelli sono di nostra produzione e non originali.
 All models are of our manufacture and are not original.
 Alle unsere Landwirtschaftliche erzeugnisse sind unsere produktion und sind nicht original.
 Tous les modèles sont notre production et ne sont pas des produits d'origine.
 Все модели нашего производства и не являются оригинальными.

N.B. Pesi e misure sopra descritti sono puramente indicativi.
 N.B. The above weights and dimensions are given for reference only.
 N.B. Die obengenannten Gewichte und Abmessungen sind richtungsweisend.
 N.B. Les poids et les dimensions indiqués ci-dessus sont donnés à titre indicatif.
 N.B. Указанные вес и размеры, являются ориентировочными.

© La riproduzione anche parziale del presente catalogo è vietata.

MOLLE
Cultivator tines
Feingrubberzinken
Dents pour vibroculteurs
Культиваторные стойки



STAFFA D'ATTACCO 90x10
PER FLEX 65x12

Clamp 90x10 for S-Tines 65x12
 Stütze 90x10 für kultizinken 65x12
 Bride 90x10 pour dents de vibro 65x12
 Стремя 90x10 для S-образной стойки 65x12

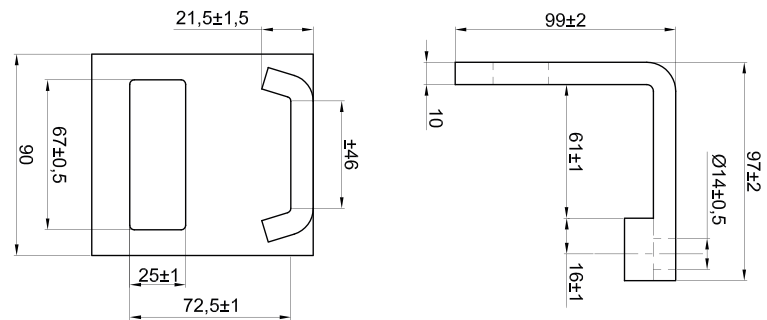
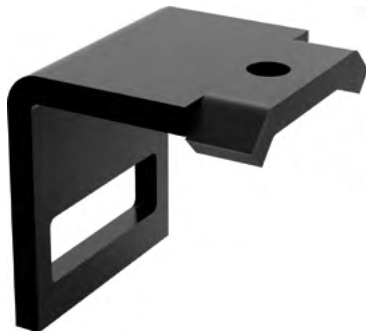

Codice Nr. Ref. Nr. Re. Nr. Ref. Nr. Код №	Altezza High Grosse Hauteur Высота mm	Telaio Frame Rahmen Chassis Рама	Molla Spring Zinken Dent Стойка	Rinforzo Auxiliary Verstärkung Renfort Подпружинник	Peso Weight Gewicht Poids Вес gr
AF6512/60	72,5		65x12	—	1,06

VOMERE A LANCIA
PER FLEX 65x12

Duck foot point 65x12
 Breitschare 65x12
 Сос с оеур 65x12
 Лапа стрельчатая 65x12

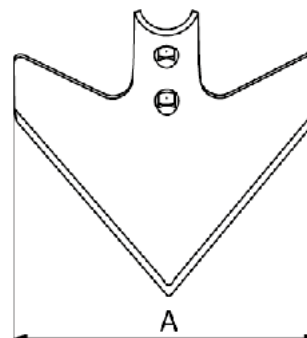

Codice Eurozappa Eurozappa Ref. Nr. Eurozappa Re. Nr. Eurozappa Ref. Nr. Код Еврозатпа №	Sezione Section Abschnitt Section Размеры A x B x C mm	Molla Tine Kulturreggenzinken Dents pour vibroculteur Культиваторная стойка mm	Bullone Bolt Schrauben Boulon Болт	Peso Weight Gewicht Poids Вес kg
550342	230x6	65x12	10x38	
550346	260x6	65x12	10x38	

MOLLE
Cultivator tines
Feingrubberzinken
Dents pour vibroculteurs
Культиваторные стойки



MOLLA FLEX 70x12
TIPO KOCKERLING

S-Tine 70x12
 Kultizinke 70x12
 Dent de vibro 70x12
 S-образная стойка 70x12

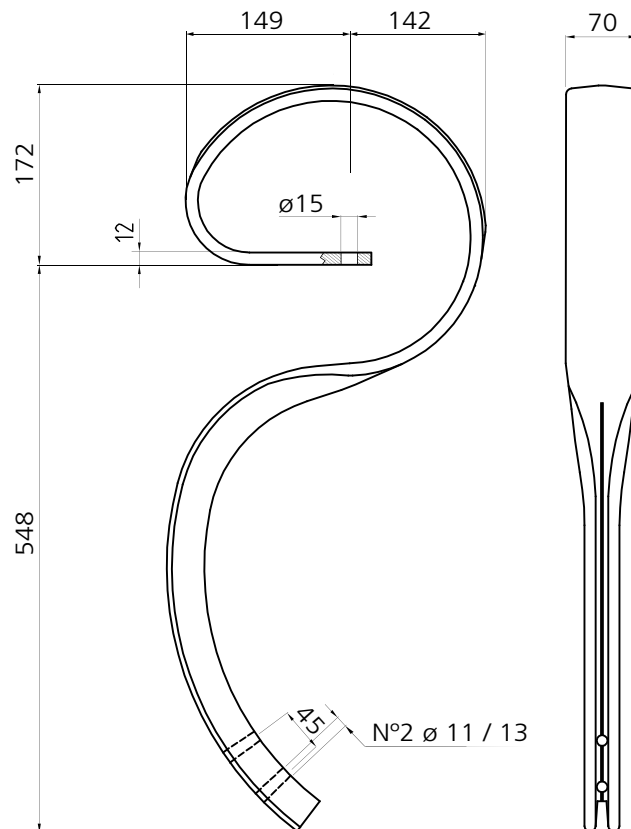

Codice Nr. Ref. Nr. Re. Nr. Ref. Nr. Код №		Quote Dimensions Abmessungen Dimensions Размеры mm	Vomere Point Schar Soc Лана mm	Interasse Center distance Achsenabstand Entraxe Расстояние Ø - Ø	Fori Holes Löcher Trous Отверстия Ø mm	Peso Weight Gewicht Poids Вес kg
F70SVV	Molla senza vomere	70x12	—	45	11	8,6
F70SVVF13	Molla senza vomere	70x12	—	45	13	8,6

Tutti i modelli sono di nostra produzione e non originali.
 All models are of our manufacture and are not original.
 Alle unsere Landwirtschaftliche erzeugnisse sind unsere produktion und sind nicht original.
 Tous les modèles sont notre production et ne sont pas des produits d'origine.
 Все модели нашего производства и не являются оригинальными.

N.B. Pesi e misure sopra descritti sono puramente indicativi.
 N.B. The above weights and dimensions are given for reference only.
 N.B. Die obengenannten Gewichte und Abmessungen sind richtungsweisend.
 N.B. Les poids et les dimensions indiqués ci-dessus sont donnés à titre indicatif.
 N.B. Указанные вес и размеры, являются ориентировочными.

© La riproduzione anche parziale del presente catalogo è vietata.

MOLLE
Cultivator tines
Feingrubberzinken
Dents pour vibroculteurs
Культиваторные стойки



STAFFA D'ATTACCO 90x10
PER FLEX 70x12

Clamp 90x10 for S-Tines 70x12
 Stütze 90x10 für kultizinken 70x12
 Bride 90x10 pour dents de vibro 70x12
 Стремя 90x10 для S-образной стойки 70x12

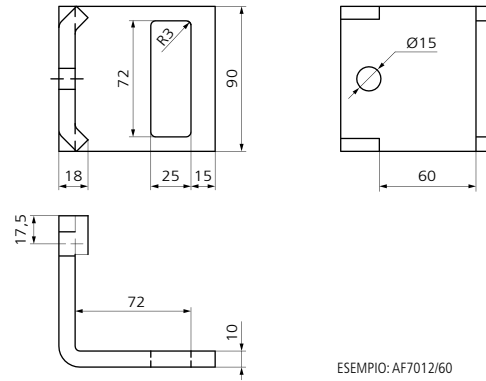

ESEMPIO: AF7012/60

Codice Nr. Ref. Nr. Re. Nr. Ref. Nr. Код №	Altezza High Grosse Hauteur Высота mm	Telaio Frame Rahmen Chassis Рама	Molla Spring Zinken Dent Стойка	Rinforzo Auxiliary Verstärkung Renfort Подпружинник	Peso Weight Gewicht Poids Вес gr
AF7012/60	72	60x60	70x12	—	1,067
AF7012/80	92	80x80	70x12	—	1,359

VOMERE REVERSIBILE PER
FLEX 70x12 TIPO KOCKERLING

Reversible point for S-Tine 70x12
 Umgekehrte Schare für gerade Kultizinke 70x12
 Soc réversible pour dent de vibro 70x12
 Двусторонняя лапа для S-образной стойки 70x12

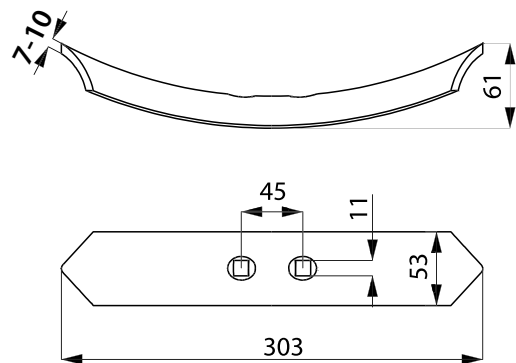

Codice Eurozappa Eurozappa Ref. Nr. Eurozappa Re. Nr. Eurozappa Ref. Nr. Код Еврозатпа №	Sezione Section Abschnitt Section Размеры mm	Bullone Bolt Schrauben Boulon Болт	Peso Weight Gewicht Poids Вес gr
VRF7012	53x7x300	10x60	0,900
550299	53x8x300	10x60	1,035
VRF7012/10	53x10x300	10x70	1,300

MOLLE
Cultivator tines
Feingrubberzinken
Dents pour vibroculteurs
Культиваторные стойки



Codice Eurozappa
Eurozappa Ref. Nr.
Eurozappa Re. Nr.
Eurozappa Ref. Nr.
Код Еврозаппа №

Sezione
Section
Abschnitt
Section
Размеры
mm

Bullone
Bolt
Schrauben
Boulon
Болт

Peso
Weight
Gewicht
Poids
Вес
gr

**VOMERE A LANCIA PER
FLEX 70×12 TIPO KOCKERLING**

Duck foot point for S-Tine 70×12
Breitschar für Kultizinke 70×12
Soc coeur pour dent de vibro 70×12
Лапа стрелчатая для S-образной стойки 70×12

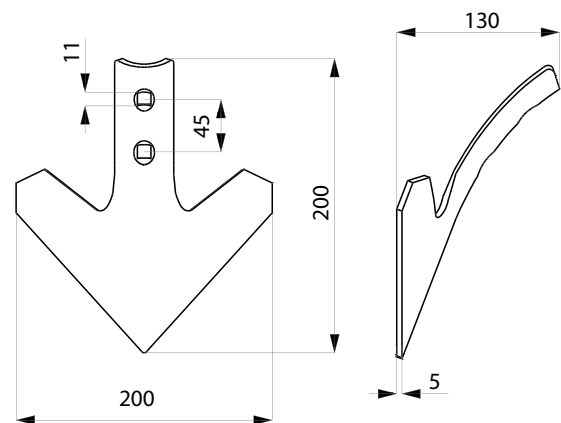

550300

200×5

—

0,880

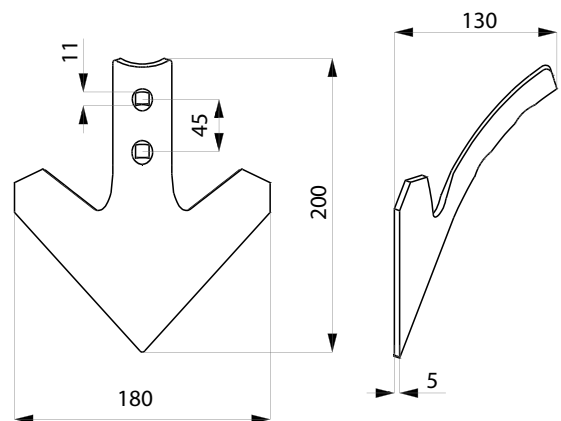

550301

180×5

—

0,860

MOLLE
Cultivator tines
Feingrubberzinken
Dents pour vibroculteurs
Культиваторные стойки



Codice Nr. Ref. Nr. Re. Nr. Ref. Nr. Код №	Sezione Section Abschnitt Section Размеры mm	Vomere Point Schar Soc Лана mm	Peso Weight Gewicht Poids Вес kg
--	---	---	---

MOLLA 150x10 E GAMBO 50x12

Spring 150x10 and Lower part 50x12
 Blattfeder 150x10 und Unterteil 50x12
 Ressort 150x10 et Partie inférieure 50x12
 Пружина 150x10 и нижняя часть 50x12

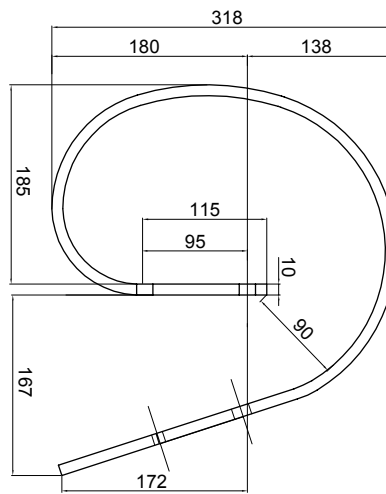

RF150

150x10

—

12

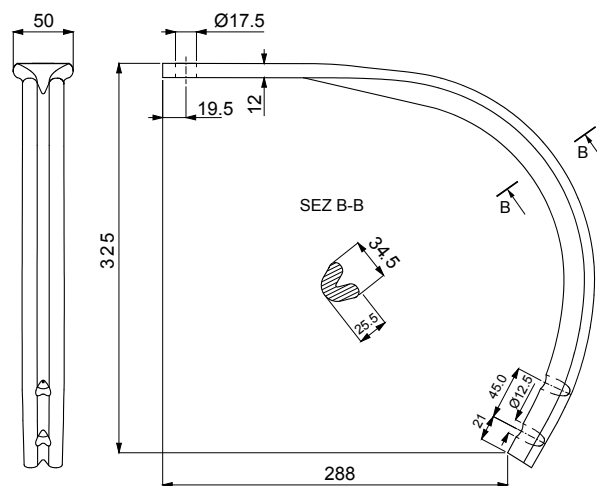

GF150

50x12

—

2,5

MOLLE
Cultivator tines
Feingrubberzinken
Dents pour vibroculteurs
Культиваторные стойки



Codice Nr. Ref. Nr. Re. Nr. Ref. Nr. Код №	Sezione Section Abschnitt Section Размеры mm	Foro Hole Löcher Trous Отверстия mm	Peso Weight Gewicht Poids Вес kg
--	---	--	---

MOLLA PER DISCO

Spring for disc
 Federzinken für Eggen Scheibe
 Dent pour disque de herse
 Стойка пружинная для диска

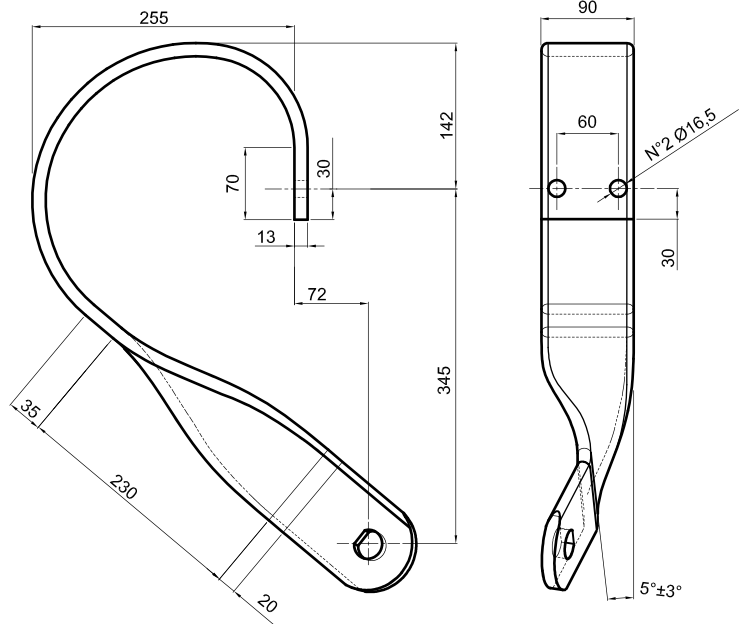

MD9014TW	90x14	28	8,6
MD9014F30TW	90x14	30	8,6

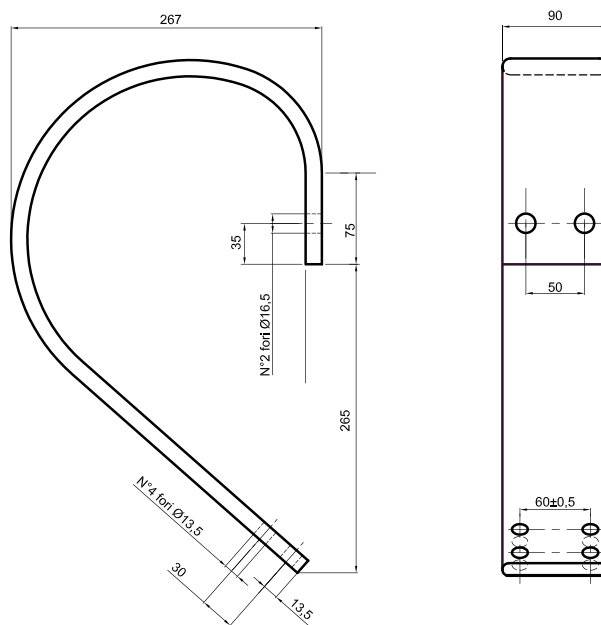

MD9014	90x14	13,5	8
---------------	--------------	-------------	----------

Tutti i modelli sono di nostra produzione e non originali.
 All models are of our manufacture and are not original.
 Alle unsere Landwirtschaftliche erzeugnisse sind unsere produktion und sind nicht original.
 Tous les modèles sont notre production et ne sont pas des produits d'origine.
 Все модели нашего производства и не являются оригинальными.

N.B. Pesi e misure sopra descritti sono puramente indicativi.
 N.B. The above weights and dimensions are given for reference only.
 N.B. Die obengenannten Gewichte und Abmessungen sind richtungsweisend.
 N.B. Les poids et les dimensions indiqués ci-dessus sont donnés à titre indicatif.
 N.B. Указанные вес и размеры, являются ориентировочными.

© La riproduzione
 anche parziale
 del presente catalogo
 è vietata.

MOLLE
Cultivator tines
Feingrubberzinken
Dents pour vibroculteurs
Культиваторные стойки



Codice Eurozappa
Eurozappa Ref. Nr.
Eurozappa Re. Nr.
Eurozappa Ref. Nr.
Код Еврозатпа №

Sezione
Section
Abschnitt
Section
Размеры
mm

Vomere
Point
Schar
Soc
Лана
mm

Peso
Weight
Gewicht
Poids
Вес
gr

MOLLA TIPO RAU 32×10 RUOTATA

S-Tine 32×10 RAU type – twisted
Schnellflusszinke 32×10 typ RAU gedreht
Dent 32×10 type RAU tordu
Стойка S-образная RAU 32×10 выкрученная

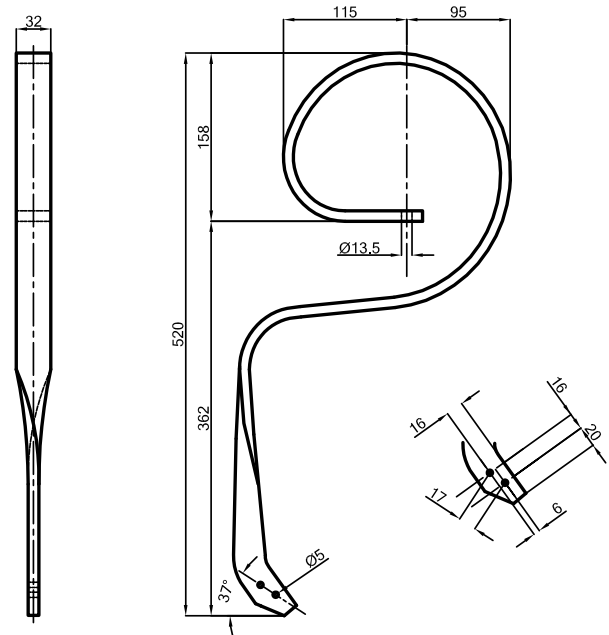

FR10R

32×10

—

2,5

VOMERE A CUORE
PER MOLLA RAU RUOTATA

Duck foot point for twisted S-Tine
Breitschar für schnellflusszinke gedreht
Soc coeur pur dent RAU tordu
Стрельчатая лапа для выкрученной S-образной стойки RAU

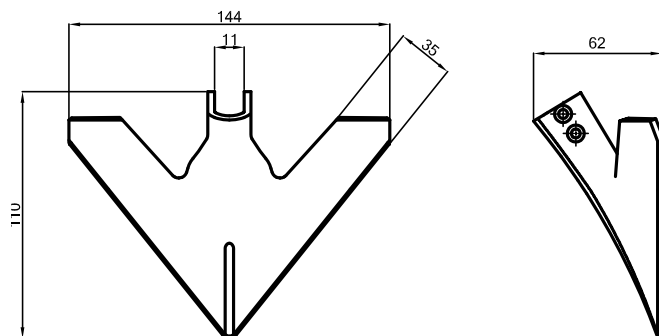

550209

165×4

—

0,21

180

Tutti i modelli sono di nostra produzione e non originali.
All models are of our manufacture and are not original.
Alle unsere Landwirtschaftliche erzeugnisse sind unsere produktion und sind nicht original.
Tous les modèles sont notre production et ne sont pas des produits d'origine.
Все модели нашего производства и не являются оригинальными.

N.B. Pesi e misure sopra descritti sono puramente indicativi.
N.B. The above weights and dimensions are given for reference only.
N.B. Die obengenannten Gewichte und Abmessungen sind richtungsweisend.
N.B. Les poids et les dimensions indiqués ci-dessus sont donnés à titre indicatif.
N.B. Указанные вес и размеры, являются ориентировочными.

© La riproduzione anche parziale del presente catalogo è vietata.

MOLLE
Cultivator tines
Feingrubberzinken
Dents pour vibroculteurs
Культиваторные стойки



Codice Nr. Ref. Nr. Re. Nr. Ref. Nr. Код №	Sezione Section Abschnitt Section Размеры mm	Telaio Frame Rahmen Cadre Рама mm	Peso Weight Gewicht Poids Вес kg	Codice Nr. Ref. Nr. Re. Nr. Ref. Nr. Код №	Sezione Section Abschnitt Section Размеры mm	Telaio Frame Rahmen Cadre Рама mm	Peso Weight Gewicht Poids Вес kg
--	---	--	---	--	---	--	---

MOLLA VADERSTAD

VADERSTAD tine
VADERSTAD Zinke
Dent VADERSTAD
Стойка VADERSTAD

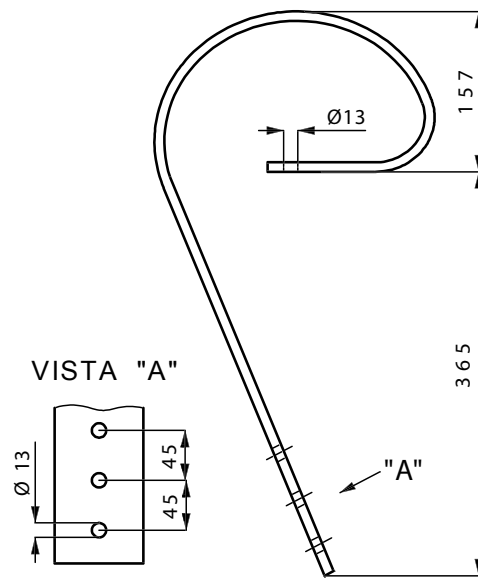
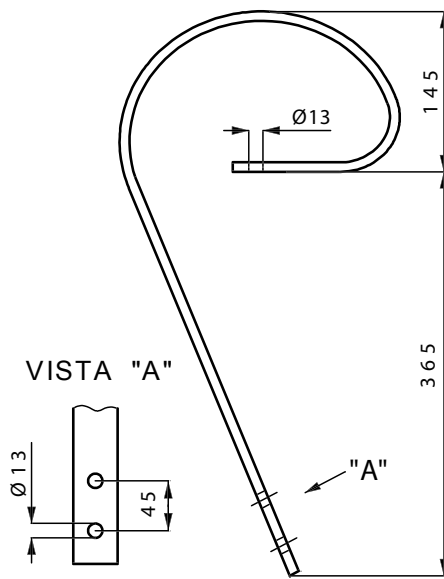

550294	45x10	50x50	3,100	550295	80x10	80x80	5,950
---------------	--------------	--------------	--------------	---------------	--------------	--------------	--------------

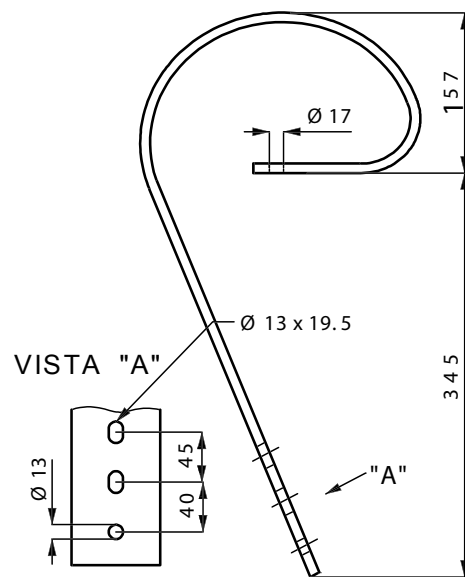
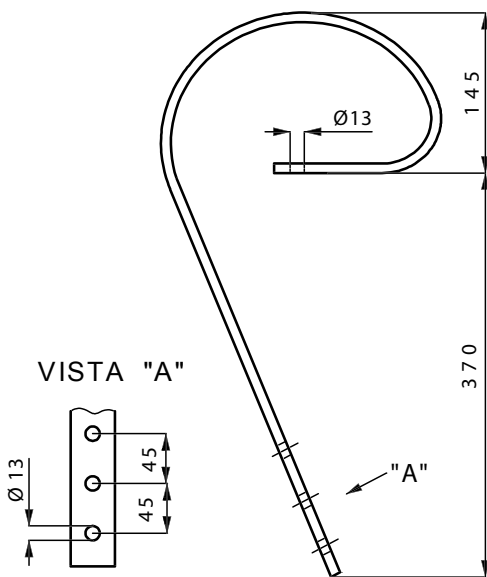

550296	45x10	50x50	3,150	550297	80x10	60x60, 70x70, 80x80	5,900
---------------	--------------	--------------	--------------	---------------	--------------	----------------------------	--------------

Tutti i modelli sono di nostra produzione e non originali.
 All models are of our manufacture and are not original.
 Alle unsere Landwirtschaftliche erzeugnisse sind unsere produktion und sind nicht original.
 Tous les modèles sont notre production et ne sont pas des produits d'origine.
 Все модели нашего производства и не являются оригинальными.

N.B. Pesi e misure sopra descritti sono puramente indicativi.
 N.B. The above weights and dimensions are given for reference only.
 N.B. Die obengenannten Gewichte und Abmessungen sind richtungsweisend.
 N.B. Les poids et les dimensions indiqués ci-dessus sont donnés à titre indicatif.
 N.B. Указанные вес и размеры, являются ориентировочными.

© La riproduzione
 anche parziale
 del presente catalogo
 è vietata.

MOLLE
Cultivator tines
Feingrubberzinken
Dents pour vibroculteurs
Культиваторные стойки



Codice Nr. Ref. Nr. Re. Nr. Ref. Nr. Код №	Sezione Section Abschnitt Section Размеры mm	Telaio Frame Rahmen Cadre Рама mm	Peso Weight Gewicht Poids Вес kg
--	---	--	---

MOLLA VADERSTAD

VADERSTAD tine
 VADERSTAD Zinke
 Dent VADERSTAD
 Стойка VADERSTAD

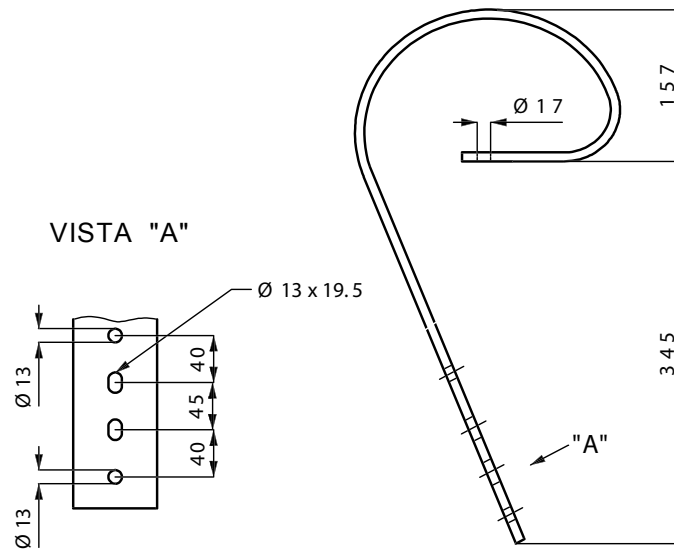

550298	80x10	60x60, 70x70, 80x80	5,900
---------------	--------------	----------------------------	--------------

Codice Nr. Ref. Nr. Re. Nr. Ref. Nr. Код №	Sezione Section Abschnitt Section Размеры mm	Peso Weight Gewicht Poids Вес kg	Codice Nr. Ref. Nr. Re. Nr. Ref. Nr. Код №	Sezione Section Abschnitt Section Размеры mm	Peso Weight Gewicht Poids Вес kg
--	---	---	--	---	---

VOMERE PER MOLLA
VADERSTAD

Point for VADERSTAD tine
 Schar für VADERSTAD Zinke
 Soc pour dent VADERSTAD
 Лапа для стойки VADERSTAD

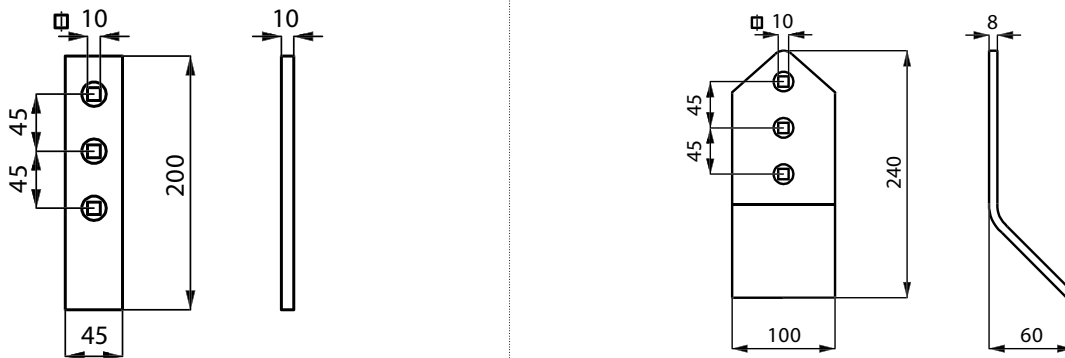

800125	45x10	0,670	800126	100x8	1,410
---------------	--------------	--------------	---------------	--------------	--------------

MOLLE
Cultivator tines
Feingrubberzinken
Dents pour vibroculteurs
Культиваторные стойки



Codice Nr. Ref. Nr. Re. Nr. Ref. Nr. Код №	Sezione Section Abschnitt Section Размеры mm	Peso Weight Gewicht Poids Bec kg	Codice Nr. Ref. Nr. Re. Nr. Ref. Nr. Код №	Sezione Section Abschnitt Section Размеры mm	Peso Weight Gewicht Poids Bec kg
--	---	---	--	---	---

VOMERE PER MOLLA
VADERSTAD

Point for VADERSTAD tine
 Schar für VADERSTAD Zinke
 Soc pour dent VADERSTAD
 Лапа для стойки VADERSTAD

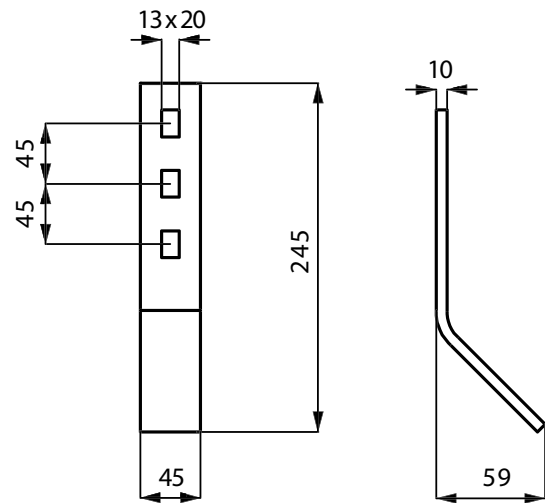
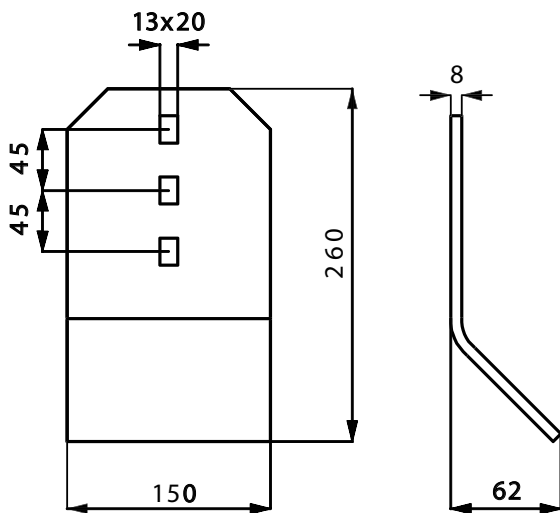

800127

150x8

2,340

800128

45x10

0,800

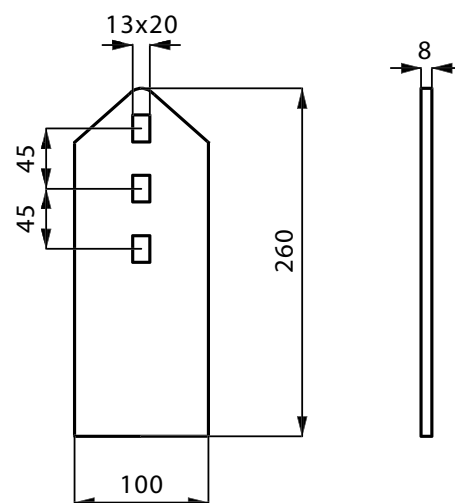
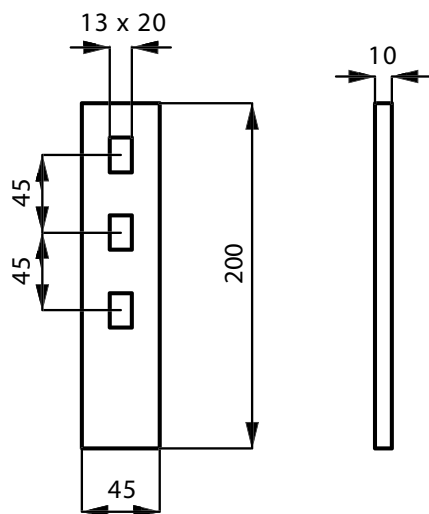

800129

45x10

0,640

800130

100x8

1,460

Tutti i modelli sono di nostra produzione e non originali.
 All models are of our manufacture and are not original.
 Alle unsere Landwirtschaftliche erzeugnisse sind unsere produktion und sind nicht original.
 Tous les modèles sont notre production et ne sont pas des produits d'origine.
 Все модели нашего производства и не являются оригинальными.

N.B. Pesi e misure sopra descritti sono puramente indicativi.
 N.B. The above weights and dimensions are given for reference only.
 N.B. Die obengenannten Gewichte und Abmessungen sind richtungsweisend.
 N.B. Les poids et les dimensions indiqués ci-dessus sont donnés à titre indicatif.
 N.B. Указанные вес и размеры, являются ориентировочными.

© La riproduzione
 anche parziale
 del presente catalogo
 è vietata.



MOLLA GARE

GARE S-Tine
 GARE Zinke
 Dent GARE
 Стойка S-образная GARE

MOLLA GARE ANTERIORE BASSA
 FRONT GARE LITTLE S-TINE
 GARE VORNE KURZE EGGENZINKE
 DENT GARE AVANT COURTE

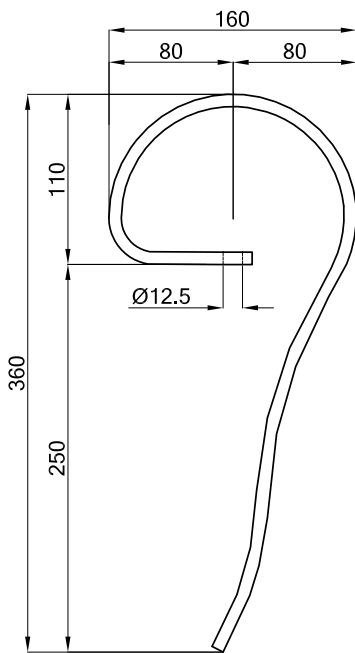

MOLLA GARE ANTERIORE ALTA
 FRONT GARE HIGH S-TINE
 GARE LANGE OBERZINKEN
 DENT GARE AVANT LONGUE

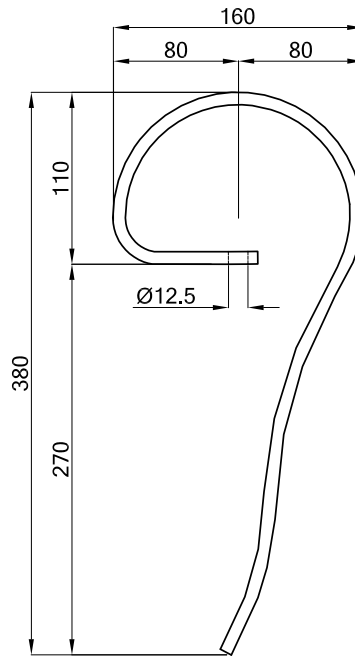

MOLLA GARE ANTERIORE TIPO SCORREVOLE
 EASY FLOW FRONT GARE S-TINE
 GARE-SCHNELLFLUSSZINKE VORNE
 DENT GARE AVANT RAU

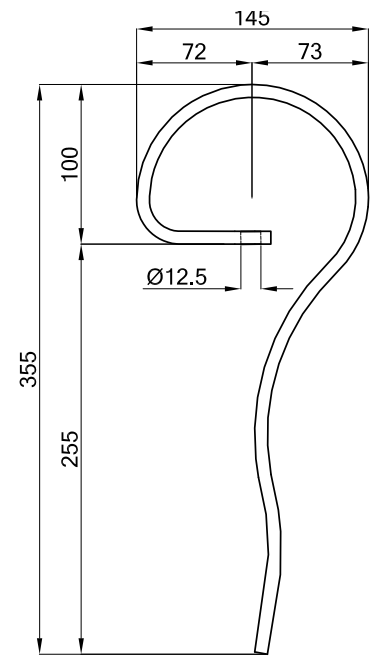

Codice Nr.
 Ref. Nr.
 Re. Nr.
 Ref. Nr.
 Код №

Sezione
 Section
 Abschnitt
 Section
 Размеры
 mm

Vomere
 Point
 Schar
 Soc
 Лана
 mm

Peso
 Weight
 Gewicht
 Poids
 Вес
 kg

	Sezione Section Abschnitt Section Размеры mm	Vomere Point Schar Soc Лана mm	Peso Weight Gewicht Poids Вес kg
G8AV	25x8	—	0,9
G8AAV	25x8	—	0,95
G8ARV	25x8	—	0,85

MOLLA GARE

GARE S-Tine
 GARE Zinke
 Dent GARE
 Стойка S-образная GARE

MOLLA GARE POSTERIORE BASSA
 BACK GARE LITTLE S-TINE
 GARE EGGENZINKE HINTEN
 DENT GARE ARRIERE COURTE

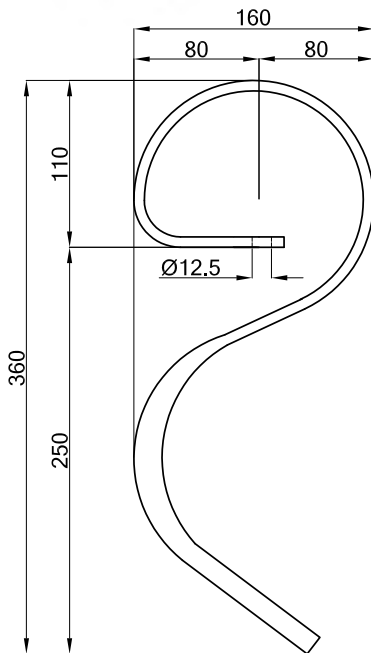

MOLLA GARE POSTERIORE ALTA
 BACK GARE HIGH S-TINE
 GARE EGGENZINKE HINTEN LANG
 DENT GARE ARRIERE LONGUE

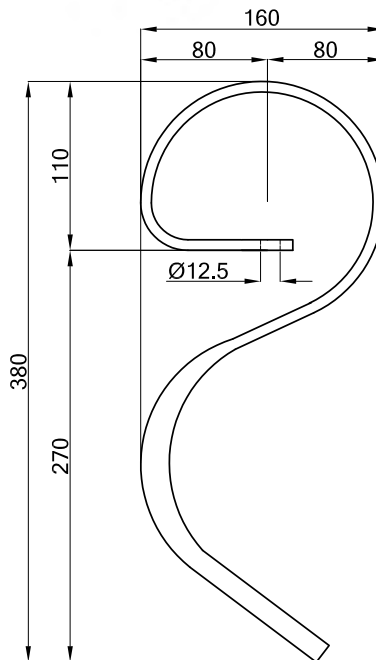

MOLLA GARE POSTERIORE TIPO SCORREVOLE
 EASY FLOW BACK GARE S-TINE
 GARE-SCHNELLFLUSSZINKE HINTEN
 DENT GARE ARRIERE RAU

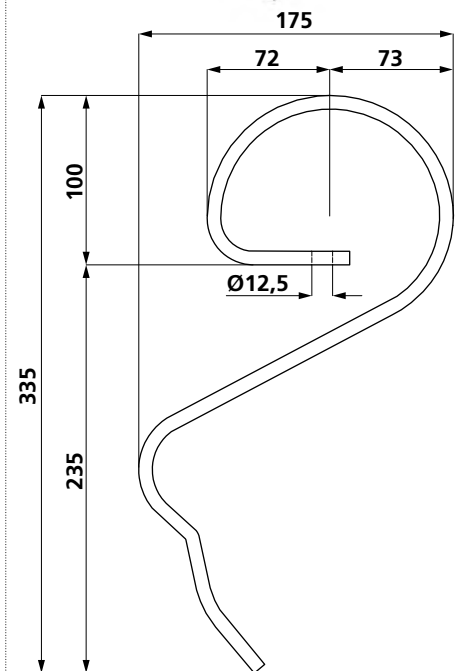

Codice Nr. Ref. Nr. Re. Nr. Ref. Nr. Код №	Sezione Section Abschnitt Section Размеры mm	Vomere Point Schar Soc Лана mm	Peso Weight Gewicht Poids Bec kg
G8PV	25x8	—	1,0
G8PAV	25x8	—	1,1
G8PRV	25x8	—	0,95

Tutti i modelli sono di nostra produzione e non originali.
 All models are of our manufacture and are not original.
 Alle unsere Landwirtschaftliche erzeugnisse sind unsere produktion und sind nicht original.
 Tous les modèles sont notre production et ne sont pas des produits d'origine.
 Все модели нашего производства и не являются оригинальными.

N.B. Pesi e misure sopra descritti sono puramente indicativi.
 N.B. The above weights and dimensions are given for reference only.
 N.B. Die obengenannten Gewichte und Abmessungen sind richtungsweisend.
 N.B. Les poids et les dimensions indiqués ci-dessus sont donnés à titre indicatif.
 N.B. Указанные вес и размеры, являются ориентировочными.

© La riproduzione
 anche parziale
 del presente catalogo
 è vietata.



**MOLLA GARE POSTERIORE
 CON FORO**

Back GARE S-Tine with hole
 GARE Hintereggzinke mit Loch
 Dent GARE arriere avec trou
 Стойка S-образная GARE задняя с отверстием

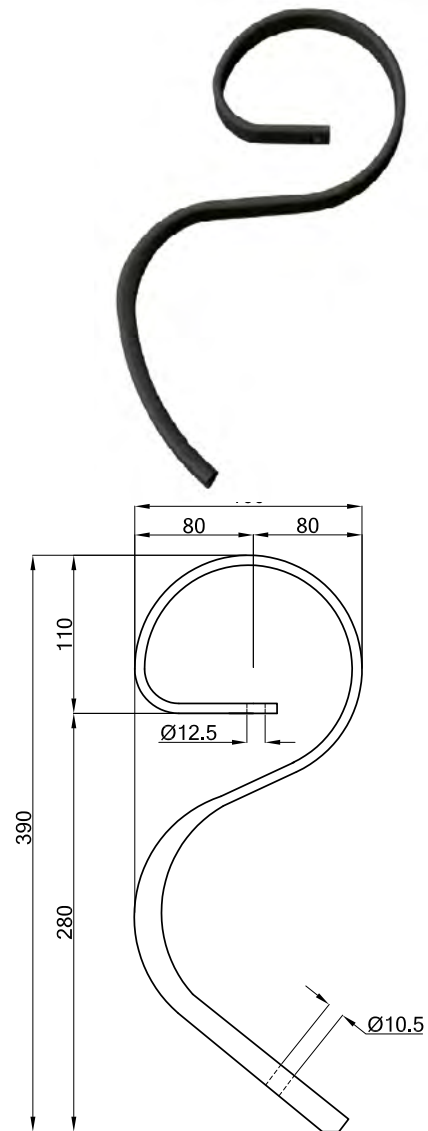
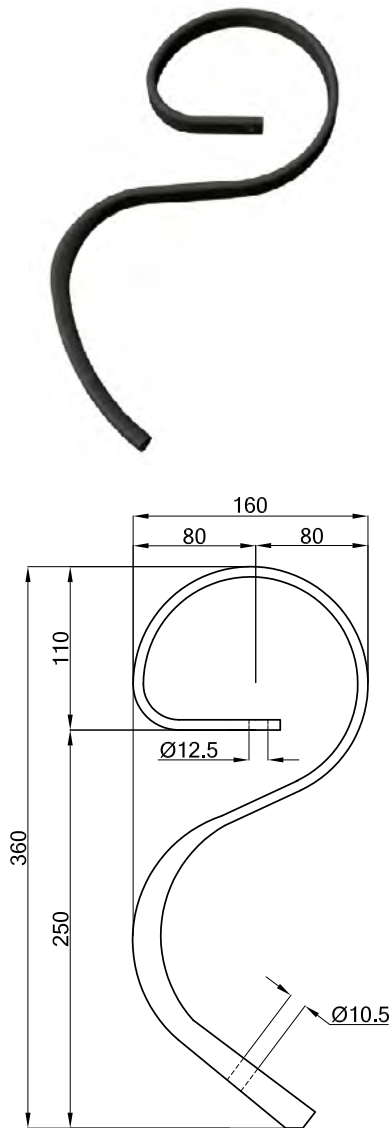

Codice Nr. Ref. Nr. Re. Nr. Ref. Nr. Код №	Sezione Section Abschnitt Section Размеры mm	Vomere Point Schar Soc Лана mm	Peso Weight Gewicht Poids Вес kg
G8SVV	25×8	—	1,0
G8CVV	25×8	VGCAN5 (40×5×135)	1,0
G10SVV	27×10	—	1,5
G10CVV	27×10	VGCAN5 (40×5×135)	1,7

MOLLA GARE 27x10 POSTERIORE

Back GARE S-Tine 27x10
 GARE Hintereggezinke 27x10 hinten
 Dent GARE 27x10 arriere
 Стойка задняя S-образная GARE 27x10

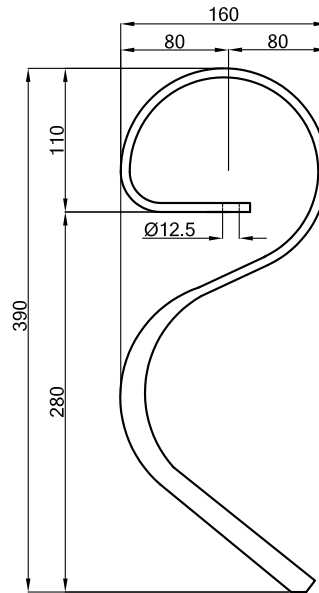

Codice Nr. Ref. Nr. Re. Nr. Ref. Nr. Код №	Sezione Section Abschnitt Section Размеры mm	Vomere Point Schar Soc Лана mm	Peso Weight Gewicht Poids Вес kg
G10PV	27x10	—	1,5

**VOMERE PER MOLLA GARE
 E VITE FLEX COMPLETA 8.8**

Point for back RAU GARE S-Tine and Nut + bolt complete
 Schar für GARE-Schnellflusszinke RAU und Scharschraube
 Soc pour dent GARE arriere RAU et Boulon complet
 Двусторонняя лапа для S-образной стойки RAU

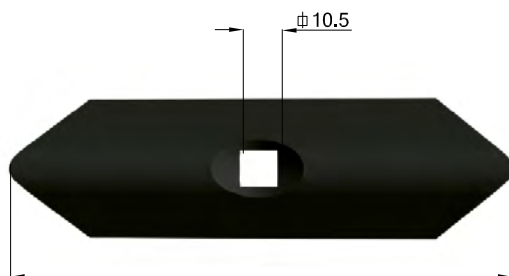

VGCAN5	40x5x135	0,200	VFC	10x38	0,032
VGCAN6	40x6x135	0,210			



**STAFFA D'ATTACCO
 PER MOLLA GARE**

Support for GARE S-tine
 Stütze für GARE Eggenzinke
 Bride pour dent GARE
 Стремя для S-образной стойки GARE

STAFFA D'ATTACCO
 PER MOLLA GARE 25×8

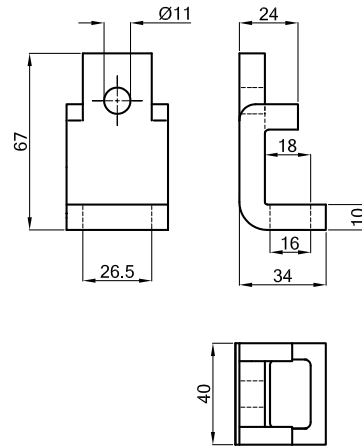
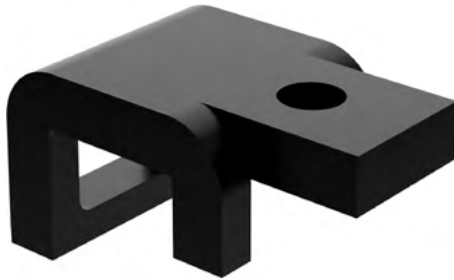

Codice Nr. Ref. Nr. Re. Nr. Ref. Nr. Код №	Altezza High Grosse Hauteu Высота mm	Telaio Frame Rahmen Chassis Рама	Molla Spring Zinken Dent Стойка	Peso Weigh Gewicht Poids Вес gr
AG25	18	40×10	GARE 25×8	0,145

STAFFA D'ATTACCO
 PER MOLLA GARE 27×10

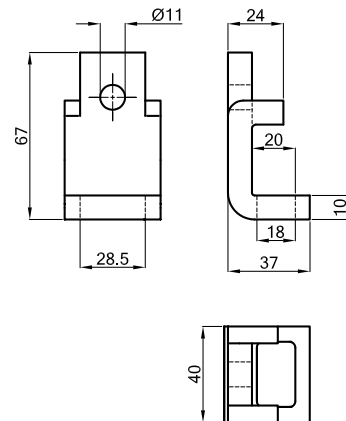
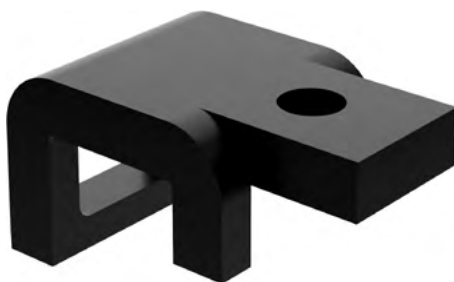

Codice Nr. Ref. Nr. Re. Nr. Ref. Nr. Код №	Altezza High Grosse Hauteu Высота mm	Telaio Frame Rahmen Chassis Рама	Molla Spring Zinken Dent Стойка	Peso Weigh Gewicht Poids Вес gr
AG27	20	40×10	GARE 27×10	0,145

**MOLLA GARE POSTERIORE RAU
 CON VOMERE**

Back GARE S-Tine RAU with point
 GARE-Schnellflusszinke RAU mit Schar
 Dent GARE arriere RAU avec soc
 Стойка S-образная задняя RAU с лапой

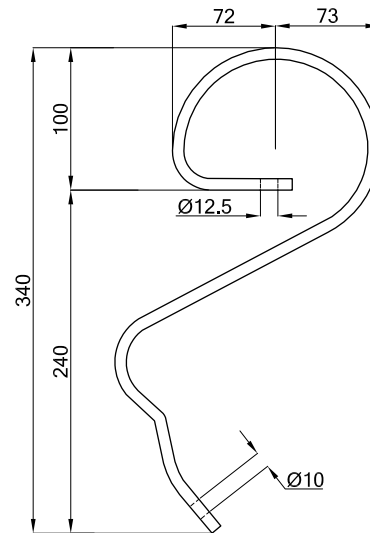

Codice Eurozappa
 Eurozappa Ref. Nr.
 Eurozappa Re. Nr.
 Eurozappa Ref. Nr.
 Код Еврозатпа №

Sezione
 Section
 Abschnitt
 Section
 Размеры
 mm

Vomere
 Point
 Schar
 Soc
 Лапа
 mm

Peso
 Weight
 Gewicht
 Poids
 Вес
 gr

G8PRCVV

25x8

550032

1,1

**VOMERE PER GARE RAU
 E VITE COMPLETA**

Point for back RAU GARE S-Tine and Nut + bolt complete
 Schar für GARE-Schnellflusszinke RAU und Scharschraube
 Soc pour dent GARE arriere RAU et Boulon complet
 Двусторонняя лапа для S-образной стойки RAU

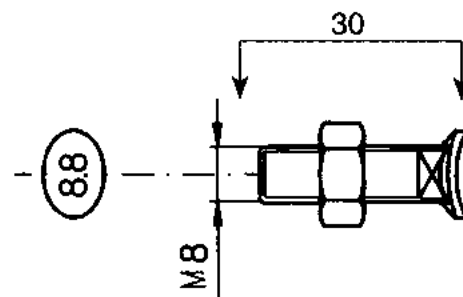
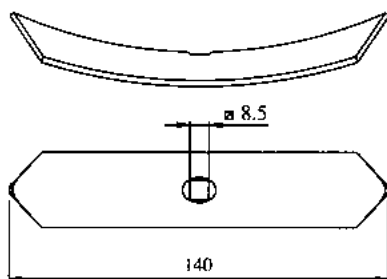

550032

25x5x140

0,130

VF8

8x30

0,017

MOLLE
Cultivator tines
Feingrubberzinken
Dents pour vibroculteurs
Культиваторные стойки



Codice Nr. Ref. Nr. Re. Nr. Ref. Nr. Код №	Sezione Section Abschnitt Section Размеры mm	Peso Weight Gewicht Poids Bec gr
--	---	---

MOLLA RUSPETTA 32x12
ATTACCO ORIZZONTALE

Straight tine ruspetta 32x12
 Gerade schnellflusszinke ruspetta 32x12
 Dent droite ruspetta 32x12
 Стойка-скребок 32x12

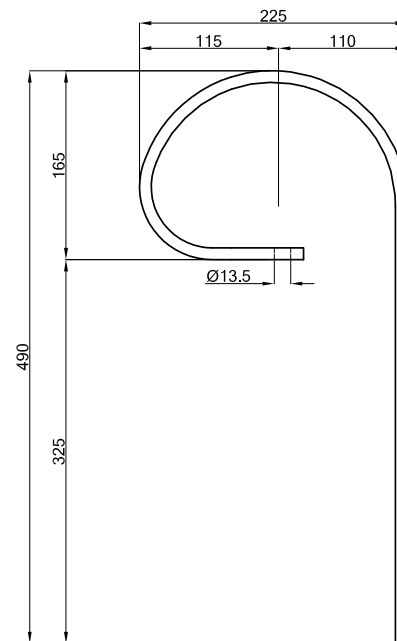

R12V	32x12	2,35
-------------	--------------	-------------

MOLLA DI PRESSIONE 32x10

Pressure tine 32x10
 Druckzinke 32x10
 Dent de pression 32x10
 Прижимная стойка 32x10

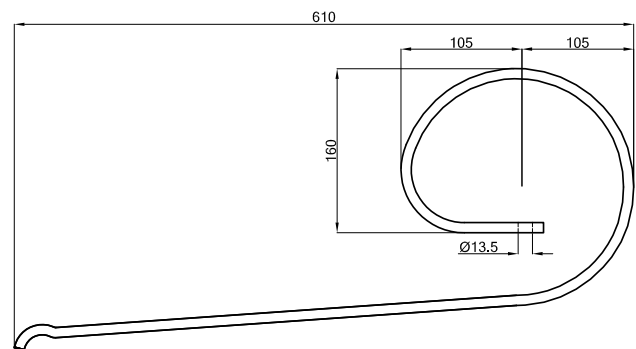

MP	32x10	2,7
-----------	--------------	------------

190

Tutti i modelli sono di nostra produzione e non originali.
 All models are of our manufacture and are not original.
 Alle unsere Landwirtschaftliche erzeugnisse sind unsere produktion und sind nicht original.
 Tous les modèles sont notre production et ne sont pas des produits d'origine.
 Все модели нашего производства и не являются оригинальными.

N.B. Pesi e misure sopra descritti sono puramente indicativi.
 N.B. The above weights and dimensions are given for reference only.
 N.B. Die obengenannten Gewichte und Abmessungen sind richtungsweisend.
 N.B. Les poids et les dimensions indiqués ci-dessus sont donnés à titre indicatif.
 N.B. Указанные вес и размеры, являются ориентировочными.

© La riproduzione anche parziale del presente catalogo è vietata.

MOLLE
Cultivator tines
Feingrubberzinken
Dents pour vibroculteurs
Культиваторные стойки



Codice Nr. Ref. Nr. Re. Nr. Ref. Nr. Код №	Sezione Section Abschnitt Section Размеры mm	Vomere Point Schar Soc Лана mm	Peso Weight Gewicht Poids Вес kg
--	---	---	---

MOLLA CANCELLATRACCIA
VERNICIATA

Trace remover
 Spurlockerzinke
 Dent effacetrace
 Стойка для удаление

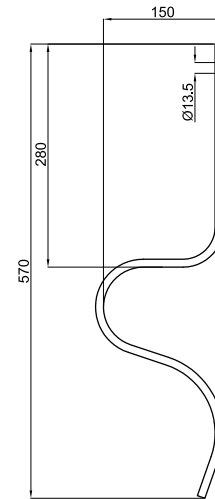

C32SVV	32×10	—	1,7
C32CVV	32×10	550136	1,95
C32CVVR (C32CVV + RC32V)	32×10	550136	2,75
C3212SVV	32×12	—	2,2
C3212CVV	32×12	550136	2,45

RINFORZO
PER CANCELLATRACCIA

Support for trace remover
 Spurlockerzinke
 Renfort pou dent effacetrace
 Подпружинник стойки для удаление

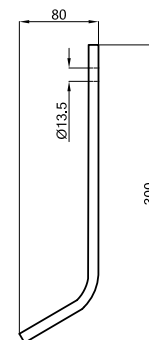

RC32V	32×10	—	0,8
-------	-------	---	-----

Tutti i modelli sono di nostra produzione e non originali.
 All models are of our manufacture and are not original.
 Alle unsere Landwirtschaftliche erzeugnisse sind unsere produktion und sind nicht original.
 Tous les modèles sont notre production et ne sont pas des produits d'origine.
 Все модели нашего производства и не являются оригинальными.

N.B. Pesi e misure sopra descritti sono puramente indicativi.
 N.B. The above weights and dimensions are given for reference only.
 N.B. Die obengenannten Gewichte und Abmessungen sind richtungsweisend.
 N.B. Les poids et les dimensions indiqués ci-dessus sont donnés à titre indicatif.
 N.B. Указанные вес и размеры, являются ориентировочными.

© La riproduzione
 anche parziale
 del presente catalogo
 è vietata.

MOLLE
Cultivator tines
Feingrubberzinken
Dents pour vibroculteurs
Культиваторные стойки



Codice Nr. Ref. Nr. Re. Nr. Ref. Nr. Код №	Sezione Section Abschnitt Section Размеры mm	Vomere Point Schar Soc Лана mm	Peso Weight Gewicht Poids Вес kg
--	---	---	---

MOLLA CANCELLATRACCIA
TIPO ALTO

Trace remover long type
 Lange Spurlockerzinke
 Dent effacetrace longue
 Стойка для удаления высокая

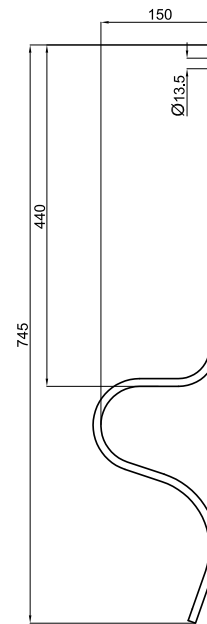

C32ASVV		32×10	—	2
C32ACVV		32×10	550136	2,55
C32ACVVR (C32ACVV + RC32AV)		32×10	550136	3,45

RINFORZO CANCELLATRACCIA
TIPO ALTO

Support for long trace remover
 Verstärkung für lange Spurlockerzinke
 Renfort pou dent effacetrace longue
 Подпружинник для высокой стойки удаления

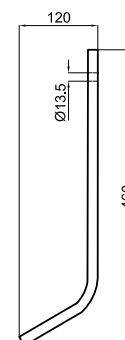

RC32AV		32×10	—	1,2
--------	--	-------	---	-----

MOLLE
Cultivator tines
Feingrubberzinken
Dents pour vibroculteurs
Культиваторные стойки



Codice Nr. Ref. Nr. Re. Nr. Ref. Nr. Код №	Sezione Section Abschnitt Section Размеры mm	Vomere Point Schar Soc Лана mm	Peso Weight Gewicht Poids Вес kg
--	---	---	---

MOLLA CANCELLATRACCIA
TIPO LARGO

Broad type
 Spurlockerzinke_weite Ausführung
 Dent effacetrace large
 Стойка для удаления широкая

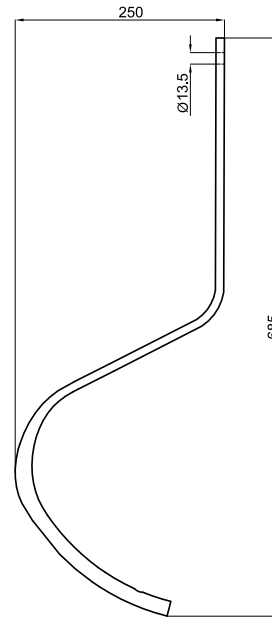

C32LSVV		32×10	—	1,9
C32LCVV		32×10	550001	2,55
C32LCVVR (C32LCVV + RC32LV)		32×10	550001	3,45

RINFORZO CANCELLATRACCIA
TIPO LARGO

Support for broad trace
 Verstärkung für weite Spurlockerzinke
 Renfort pou dent effacetrace large
 Подпружинник для широкой стойки удаления

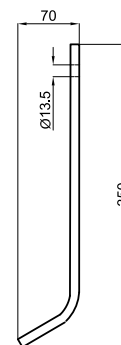

RC32LV		32×10	—	0,85
--------	--	-------	---	------

Tutti i modelli sono di nostra produzione e non originali.
 All models are of our manufacture and are not original.
 Alle unsere Landwirtschaftliche erzeugnisse sind unsere produktion und sind nicht original.
 Tous les modèles sont notre production et ne sont pas des produits d'origine.
 Все модели нашего производства и не являются оригинальными.

N.B. Pesi e misure sopra descritti sono puramente indicativi.
 N.B. The above weights and dimensions are given for reference only.
 N.B. Die obengenannten Gewichte und Abmessungen sind richtungsweisend.
 N.B. Les poids et les dimensions indiqués ci-dessus sont donnés à titre indicatif.
 N.B. Указанные вес и размеры, являются ориентировочными.

© La riproduzione
 anche parziale
 del presente catalogo
 è vietata.

MOLLE
Cultivator tines
Feingrubberzinken
Dents pour vibroculteurs
Культиваторные стойки



Codice Nr. Ref. Nr. Re. Nr. Ref. Nr. Код №	Sezione Section Abschnitt Section Размеры mm	Vomere Point Schar Soc Лана mm	Peso Weight Gewicht Poids Вес kg
--	---	---	---

MOLLA CANCELLATRACCIA

Trace remover
 Spurlockerzinke
 Dent effacetrace
 Стойка для удаления

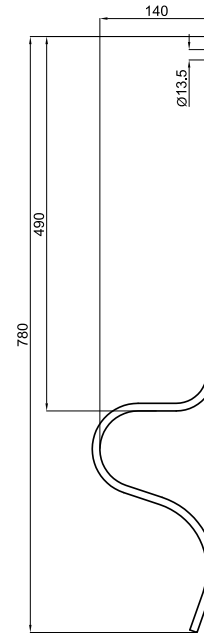

C40SVV	40×10	—	2,8
C40CVV	40×10	550001	3,1
C40CVVR (C40CVV + RC40V)	40×10	550001	4,8

RINFORZO PER CANCELLATRACCIA

Support for trace remover
 Verstärkung für Spurlockerzinke
 Renfort pou dent effacetrace
 Подпружинник для стойки удаления

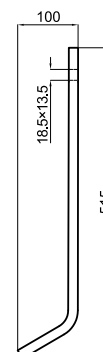

RC40V	40×10	—	1,7
--------------	-------	---	-----

MOLLE
Cultivator tines
Feingrubberzinken
Dents pour vibroculteurs
Культиваторные стойки



Codice Eurozappa
 Eurozappa Ref. Nr.
 Eurozappa Re. Nr.
 Eurozappa Ref. Nr.
 Код Еврозаппа №

Sezione
 Section
 Abschnitt
 Section
 Размеры
 A x B mm

Molla
 Tine
 Kultureggenzinken
 Dents pour vibroculteur
 Культиваторная стойка
 mm

Bullone
 Bolt
 Schrauben
 Boulon
 Болт

Peso
 Weight
 Gewicht
 Poids
 Вес
 kg

VOMERE PER MOLLA
CANCELLATRACCIA

Reversible point for trace remover
 Umgekehrte Schar für Spurlockerzinke
 Reversible soc pour dent effacetrace
 Двусторонняя лапа для стойки удаления

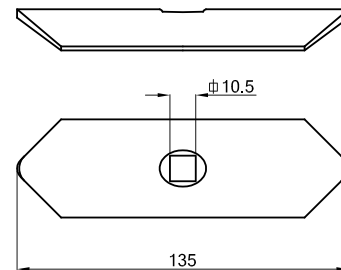

550135		40x5x135	C32CVV / C32ACVV	VFC	0,210
550136		40x6x135	C32CVV / C32ACVV	VFC	0,230

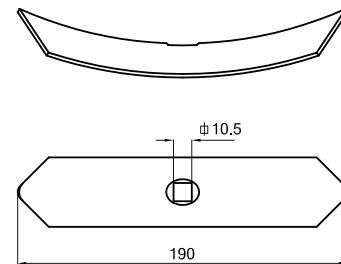

550001	VRF5	40x5x190	C32LCVV / C40CVV	VFC	0,270
550031	VRF6	40x6x190	C32LCVV / C40CVV	VFC	0,310

VITE FLEX COMPLETA
PER VOMERE CANCELLATRACCIA
IN 8.8

Nut + bolt complete for trace remover point
 Scharschraube für Spurlockerzinke
 Boulon complet pour soc de dent effacetrace
 Болт с гайкой в комплекте для стойки удаления

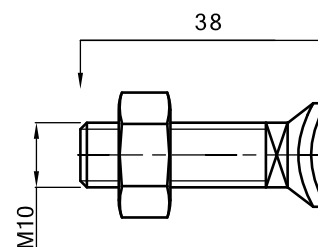

VFC		10x38			0,032
-----	--	-------	--	--	-------

Tutti i modelli sono di nostra produzione e non originali.
 All models are of our manufacture and are not original.
 Alle unsere Landwirtschaftliche erzeugnisse sind unsere produktion und sind nicht original.
 Tous les modèles sont notre production et ne sont pas des produits d'origine.
 Все модели нашего производства и не являются оригинальными.

N.B. Pesi e misure sopra descritti sono puramente indicativi.
 N.B. The above weights and dimensions are given for reference only.
 N.B. Die obengenannten Gewichte und Abmessungen sind richtungsweisend.
 N.B. Les poids et les dimensions indiqués ci-dessus sont donnés à titre indicatif.
 N.B. Указанные вес и размеры, являются ориентировочными.

© La riproduzione
 anche parziale
 del presente catalogo
 è vietata.

MOLLE
Cultivator tines
Feingrubberzinken
Dents pour vibroculteurs
Культиваторные стойки



Codice Nr. Ref. Nr. Re. Nr. Ref. Nr. Код №	Sezione Section Abschnitt Section Размеры mm	Vomere Point Schar Soc Лана mm	Peso Weight Gewicht Poids Вес kg
--	---	---	---

MOLLA STRIPEL

STRIPEL tine
 STRIPEL Zinke
 Dent STRIPEL
 Стойка STRIPEL

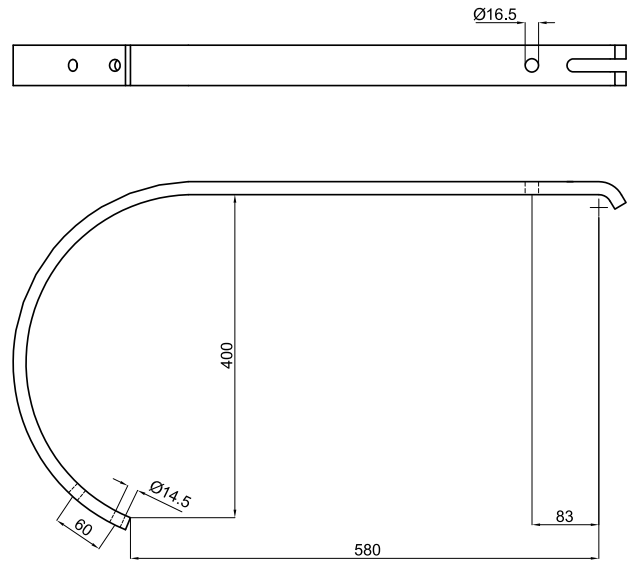

S16SVV

50x16

—

5,6

MOLLA STRIPEL TIPO ALTO

Long STRIPEL tine
 Lange STRIPEL Zinke
 Dent STRIPEL longue
 Стойка STRIPEL высокая

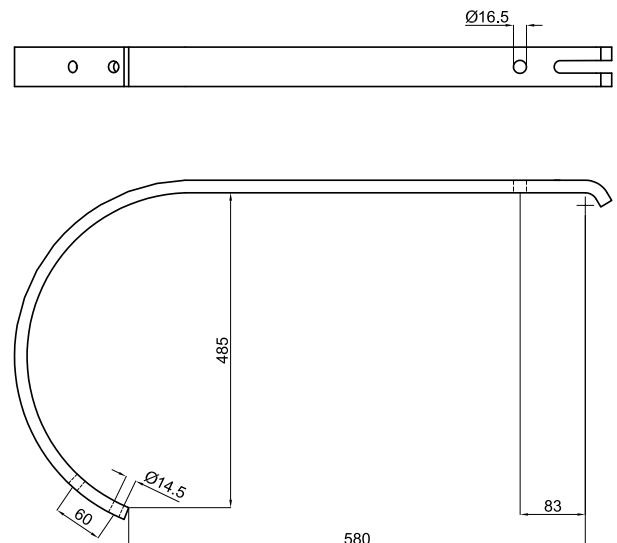

S16ASVV

50x16

—

6,1

196

Tutti i modelli sono di nostra produzione e non originali.
 All models are of our manufacture and are not original.
 Alle unsere Landwirtschaftliche erzeugnisse sind unsere produktion und sind nicht original.
 Tous les modèles sont notre production et ne sont pas des produits d'origine.
 Все модели нашего производства и не являются оригинальными.

N.B. Pesi e misure sopra descritti sono puramente indicativi.
 N.B. The above weights and dimensions are given for reference only.
 N.B. Die obengenannten Gewichte und Abmessungen sind richtungsweisend.
 N.B. Les poids et les dimensions indiqués ci-dessus sont donnés à titre indicatif.
 N.B. Указанные вес и размеры, являются ориентировочными.

© La riproduzione anche parziale del presente catalogo è vietata.

MOLLA TIPO ITALIANO

Multiblade S-Tine
 Mehrblatt Federzinke
 Ressort plurilame
 S-образная рессорная стойка

I25SVV

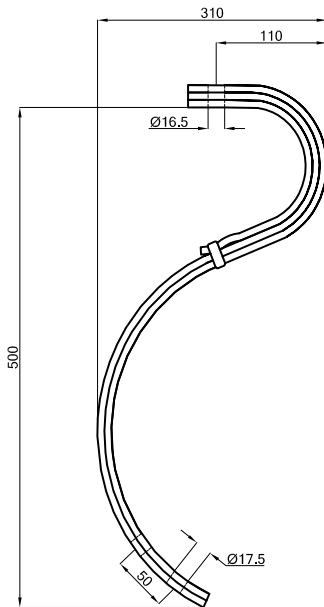

I35SVV

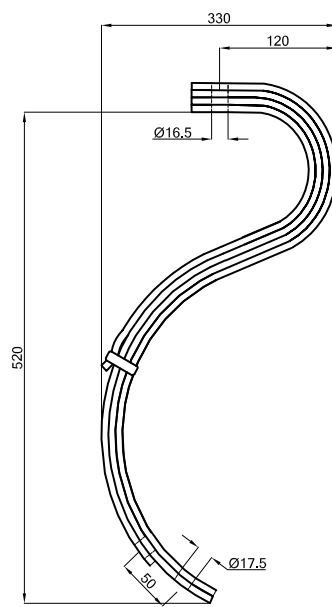

I45SVV

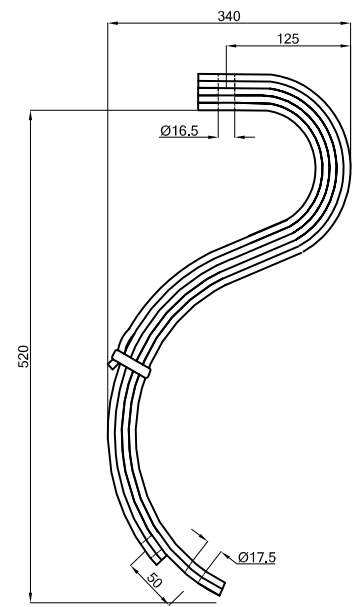

Codice Nr. Ref. Nr. Re. Nr. Ref. Nr. Код №	Sezione Section Abschnitt Section Размеры mm	Composizione (foglie) Composition (sheets) Zusammensetzung (Blätter) Composition (lames) Композиция (листов)	Vomere Point Schar Soc Лана mm	Peso Weight Gewicht Poids Вес kg
I25SVV	45x7	2½	—	5,0
I25CVV	45x7	2½	550016	5,5
I35SVV	45x7	3½	—	7,5
I35CVV	45x7	3½	550016	8,0
I45SVV	45x7	4½	—	9,5
I45CVV	45x7	4½	550016	10,00

Tutti i modelli sono di nostra produzione e non originali.
 All models are of our manufacture and are not original.
 Alle unsere Landwirtschaftliche erzeugnisse sind unsere produktion und sind nicht original.
 Tous les modèles sont notre production et ne sont pas des produits d'origine.
 Все модели нашего производства и не являются оригинальными.

N.B. Pesi e misure sopra descritti sono puramente indicativi.
 N.B. The above weights and dimensions are given for reference only.
 N.B. Die obengenannten Gewichte und Abmessungen sind richtungsweisend.
 N.B. Les poids et les dimensions indiqués ci-dessus sont donnés à titre indicatif.
 N.B. Указанные вес и размеры, являются ориентировочными.

© La riproduzione
 anche parziale
 del presente catalogo
 è vietata.



MOLLA TIPO ITALIANO

Multiblade type italiano
 Federzinke Italien Typ
 Dent typ italiano
 Стойка итальянского типа

I25M
 TIPO M

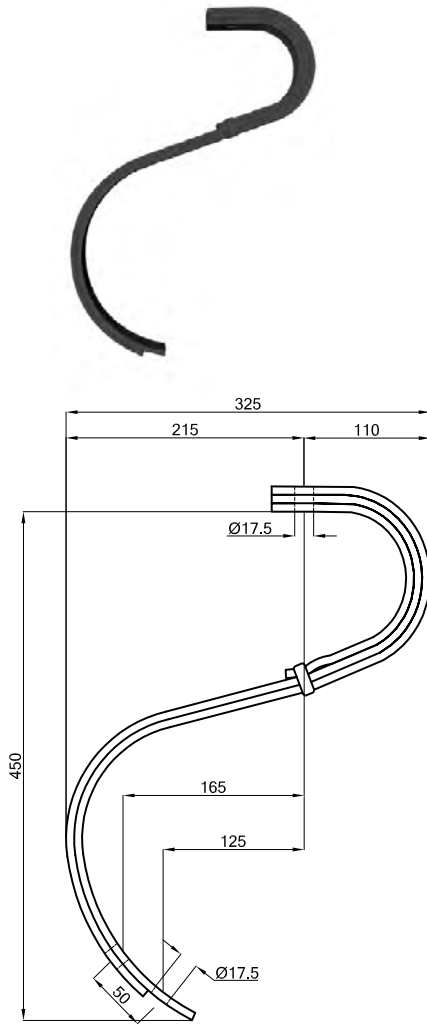

I25F
 TIPO F

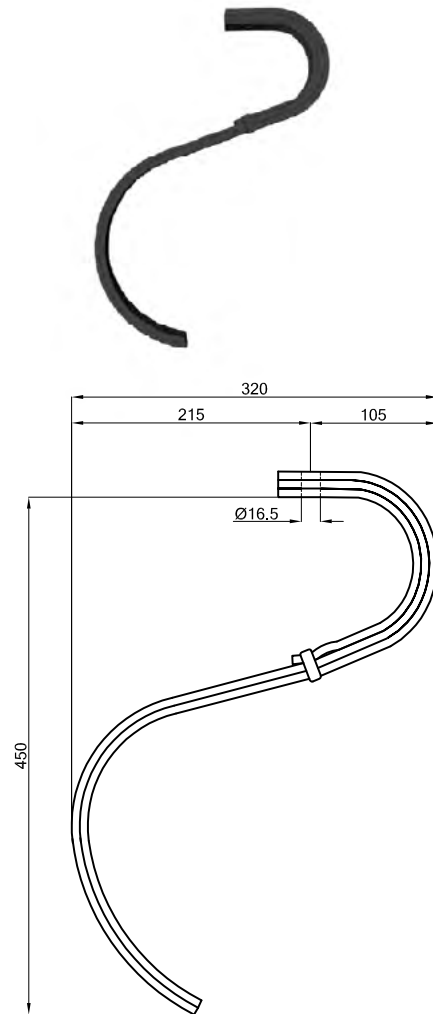

Codice Nr. Ref. Nr. Re. Nr. Ref. Nr. Код №	Sezione Section Abschnitt Section Размеры mm	Composizione (foglie) Composition (sheets) Zusammensetzung (Blätter) Composition (lames) Композиция (листов)	Vomere Point Schar Soc Лана mm	Peso Weight Gewicht Poids Вес kg
I25M	45x7	2½	—	4,70
I25F	45x7	2½	—	4,88

MOLLA VENTZKY

VENTZKY-Tine
 VENTZKY-Zinke
 Dent-VENTZKY
 Стойка VENTZKY

V15SVV

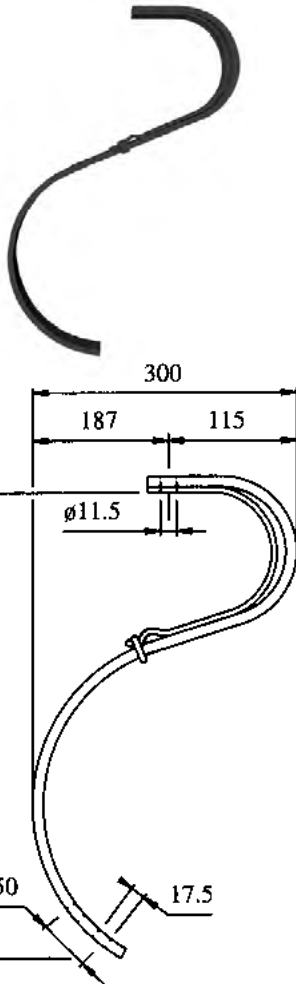

V4072SVV

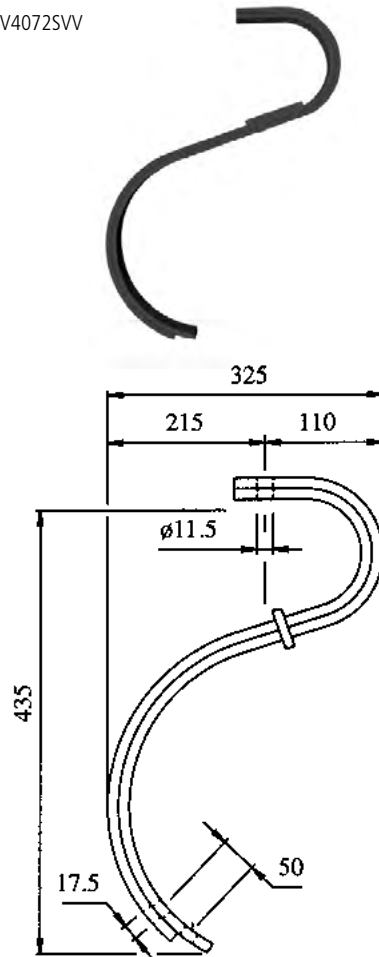

V407SVV

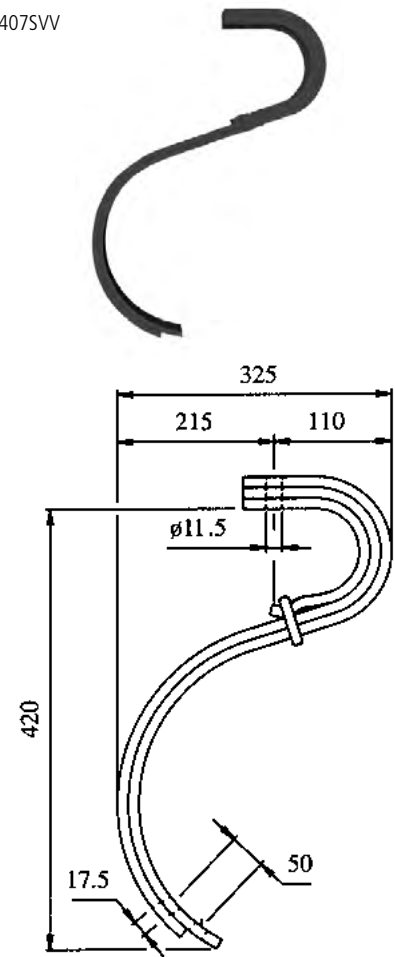

Codice Nr. Ref. Nr. Re. Nr. Ref. Nr. Код №	Sezione Section Abschnitt Section Размеры mm	Composizione (foglie) Composition (sheets) Zusammensetzung (Blätter) Composition (lames) Композиция (листов)	Vomere Point Schar Soc Лана mm	Peso Weight Gewicht Poids Вес kg
V15SVV	40x7	1	—	2,3
	40x5	½	—	
V15CVV		1½	550016	2,8
V4072SVV	40x7	—	—	3,2
V4072CVV		2	550016	3,7
V407SVV	40x7	2	—	3,7
	40x5	½	—	
V407CVV		2½	550016	4,2

Tutti i modelli sono di nostra produzione e non originali.
 All models are of our manufacture and are not original.
 Alle unsere Landwirtschaftliche erzeugnisse sind unsere produktion und sind nicht original.
 Tous les modèles sont notre production et ne sont pas des produits d'origine.
 Все модели нашего производства и не являются оригинальными.

N.B. Pesi e misure sopra descritti sono puramente indicativi.
 N.B. The above weights and dimensions are given for reference only.
 N.B. Die obengenannten Gewichte und Abmessungen sind richtungsweisend.
 N.B. Les poids et les dimensions indiqués ci-dessus sont donnés à titre indicatif.
 N.B. Указанные вес и размеры, являются ориентировочными.

© La riproduzione
 anche parziale
 del presente catalogo
 è vietata.

MOLLE
Cultivator tines
Feingrubberzinken
Dents pour vibroculteurs
Культиваторные стойки



**ATTACCO COMPLETO
 PER MOLLA TIPO ITALIANO**

Complete support for multiblades-tines
 Stütze für Mehrblatt Federzinken
 Bride complet pour ressort plurilame
 Стремя в комплекте для S-образной рессорной стойки

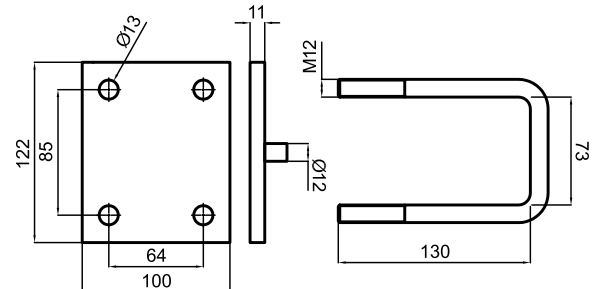

ESEMPIO: AI35

Codice Nr. Ref. Nr. Re. Nr. Ref. Nr. Код №	Sezione Section Abschnitt Section Размеры мм	Piastre Plate Platte Plaque Профиль мм	Bullone Bolt Schrauben Boulon Болт мм	Peso Weight Gewicht Poids Вес kg
AI35	70 (tub.)	—	—	1,57
AI45	80 (tub.)	—	—	1,65

**VOMERE PER MOLLA TIPO
 ITALIANO E VENTZKY**

Reversible point for multiblade S-Tine and VENTZKY S-Tine
 Schare für Mehrblatt Federzinke und Ventzky-Zinke
 Soc réversible pour ressort plurilame et Dent-VENTZKY
 Двусторонняя лапа для стоек S-образной рессорной и VENTZKY

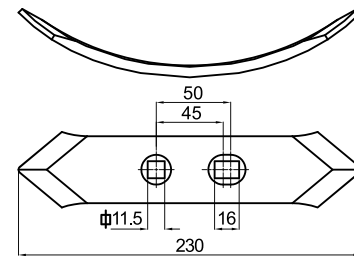

550016	45x7	—	—	0,460
--------	------	---	---	-------

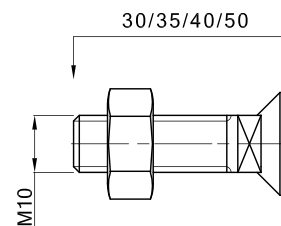

B1030	10x30	—	—	—
B1035	10x35	—	—	—
B1040	10x40	—	—	—
B1050	10x50	—	—	—

200

Tutti i modelli sono di nostra produzione e non originali.
 All models are of our manufacture and are not original.
 Alle unsere Landwirtschaftliche erzeugnisse sind unsere produktion und sind nicht original.
 Tous les modèles sont notre production et ne sont pas des produits d'origine.
 Все модели нашего производства и не являются оригинальными.

N.B. Pesi e misure sopra descritti sono puramente indicativi.
 N.B. The above weights and dimensions are given for reference only.
 N.B. Die obengenannten Gewichte und Abmessungen sind richtungsweisend.
 N.B. Les poids et les dimensions indiqués ci-dessus sont donnés à titre indicatif.
 N.B. Указанные вес и размеры, являются ориентировочными.

© La riproduzione
 anche parziale
 del presente catalogo
 è vietata.



MOLLA CHISEL MONOLAMA

Single blade Chased spring
 Einblattsfeder
 Chisel monolame
 Стойка чизельная

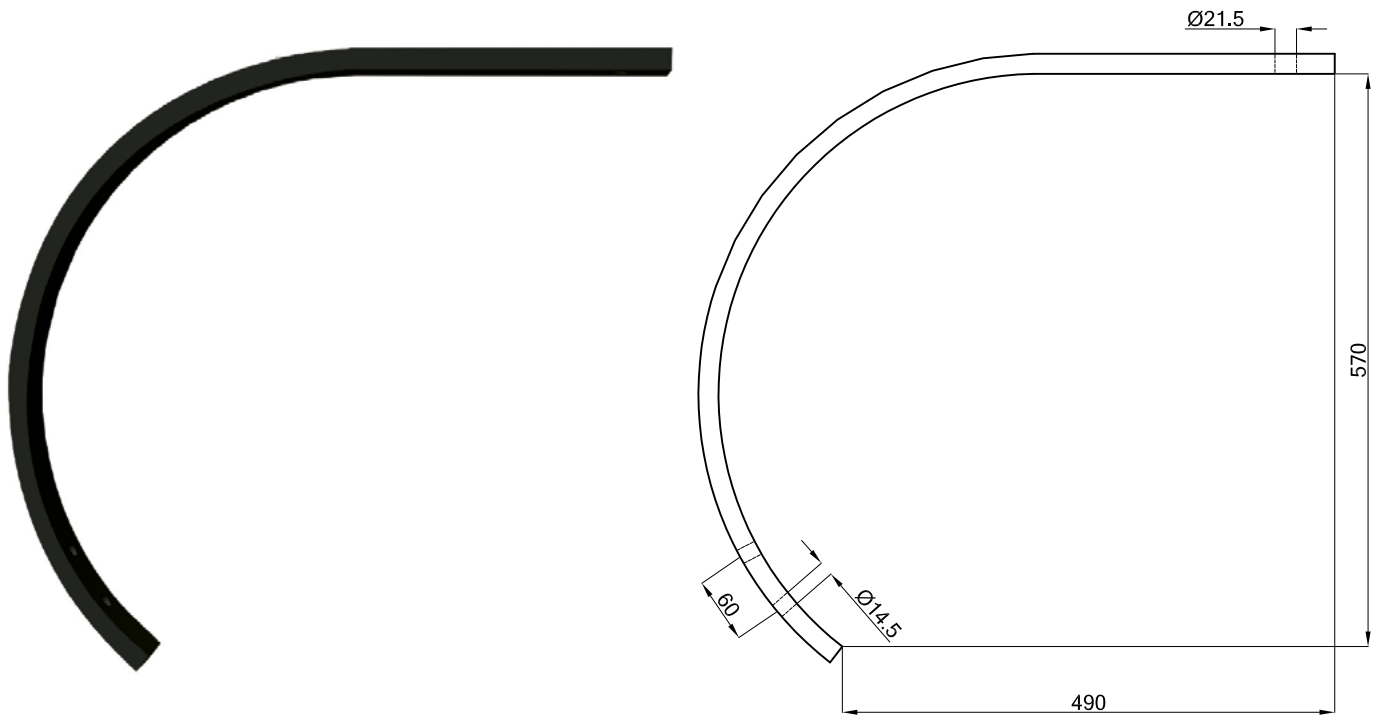

Codice Nr. Ref. Nr. Re. Nr. Ref. Nr. Код №	Sezione Section Abschnitt Section Размеры mm	Vomere Point Schar Soc Лана mm	Peso Weight Gewicht Poids Вес kg
M20SVV	55x20	—	8,8
M20CVV	55x20	800019	11,00
M25SVV	55x25	—	10,8
M25CVV	55x25	800019	13,00

Tutti i modelli sono di nostra produzione e non originali.
 All models are of our manufacture and are not original.
 Alle unsere Landwirtschaftliche erzeugnisse sind unsere produktion und sind nicht original.
 Tous les modèles sont notre production et ne sont pas des produits d'origine.
 Все модели нашего производства и не являются оригинальными.

N.B. Pesi e misure sopra descritti sono puramente indicativi.
 N.B. The above weights and dimensions are given for reference only.
 N.B. Die obengenannten Gewichte und Abmessungen sind richtungsweisend.
 N.B. Les poids et les dimensions indiqués ci-dessus sont donnés à titre indicatif.
 N.B. Указанные вес и размеры, являются ориентировочными.

© La riproduzione anche parziale del presente catalogo è vietata.



MOLLA CHISEL BILAMA

Double blade Chisel spring
 2 Doppelblattsfeder
 Chisel bilame
 Стойка чизельная двухпрофильная

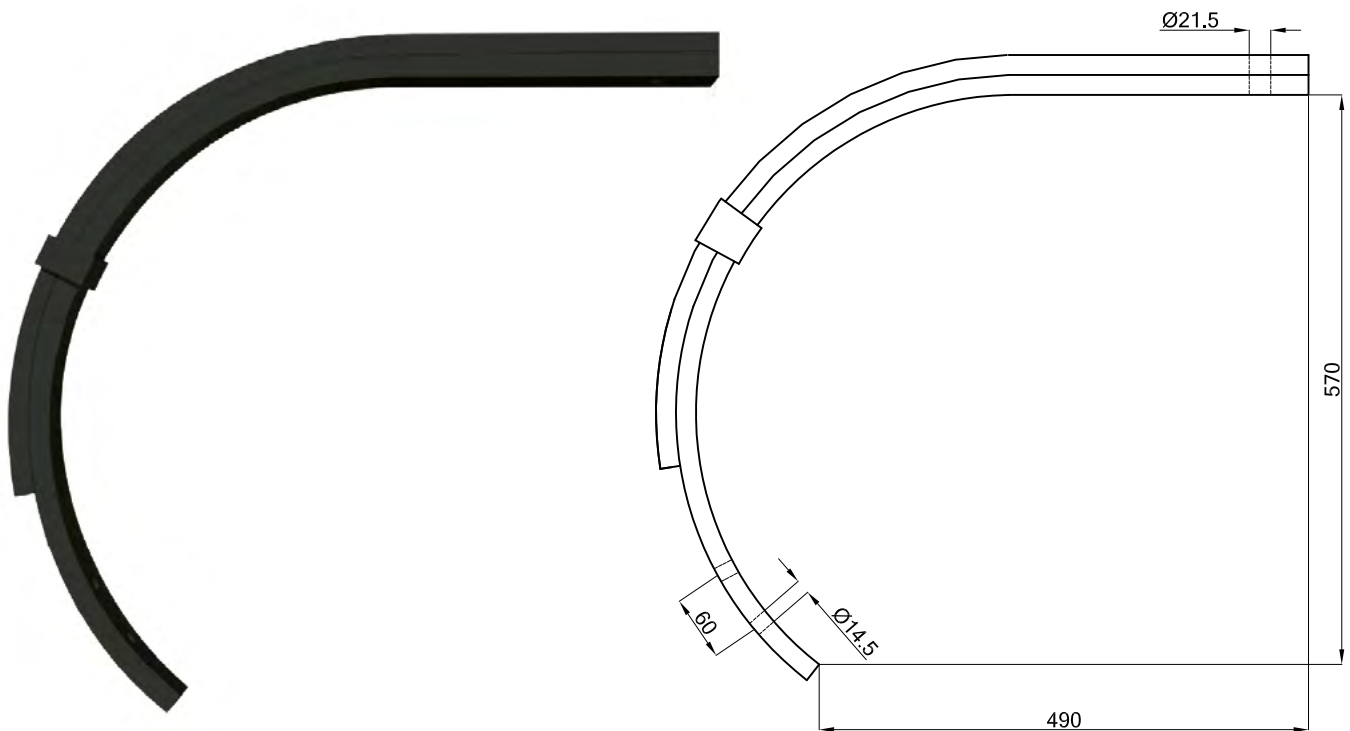

Codice Nr. Ref. Nr. Re. Nr. Ref. Nr. Код №	Sezione Section Abschnitt Section Размеры mm	Vomere Point Schar Soc Лана mm	Peso Weight Gewicht Poids Bec kg
B20SVV	55x20 + 55x20	—	15,65
B20CVV	55x20 + 55x20	800019	17,9
B20CVV60	55x20 + 55x20	800058	18,9
B25SVV	55x25 + 55x25	—	20,25
B25CVV	55x25 + 55x25	800019	22,5
B25CVV60	55x25 + 55x25	800058	23,5
B2520SVV	55x25 + 55x20	—	17,7
B2520CVV	55x25 + 55x20	800019	19,9
B2520CVV60	55x25 + 55x20	800058	21,0

MOLLA CHISEL

Chisel-Spring
 Einblatt Chisel-Feder
 Chisel monolame
 Стойка чизельная

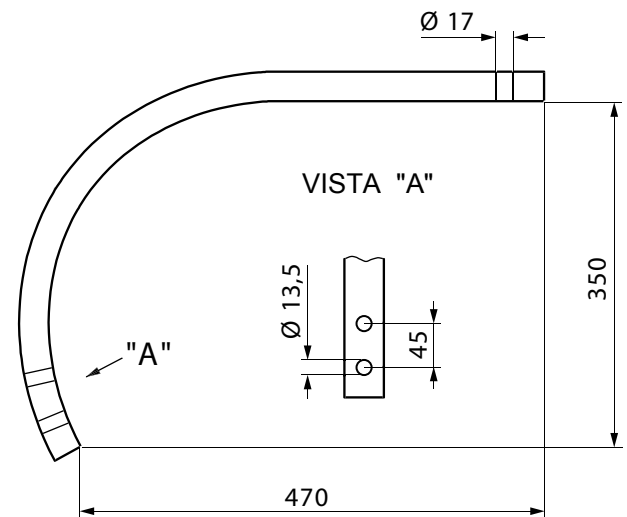
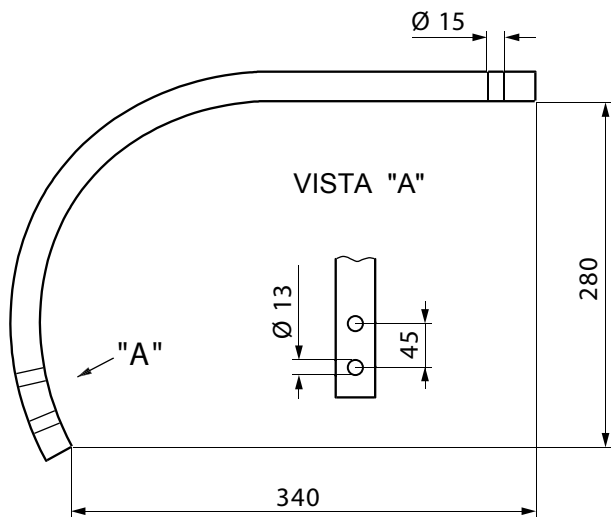

CH25SVV

25x25

3,250

CH30SVV

30x30

5,540

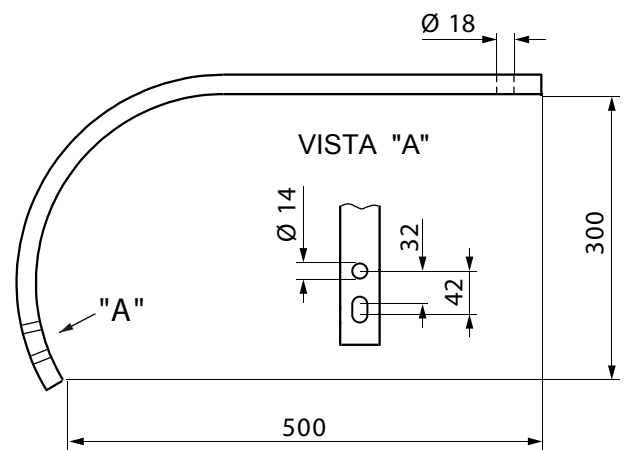
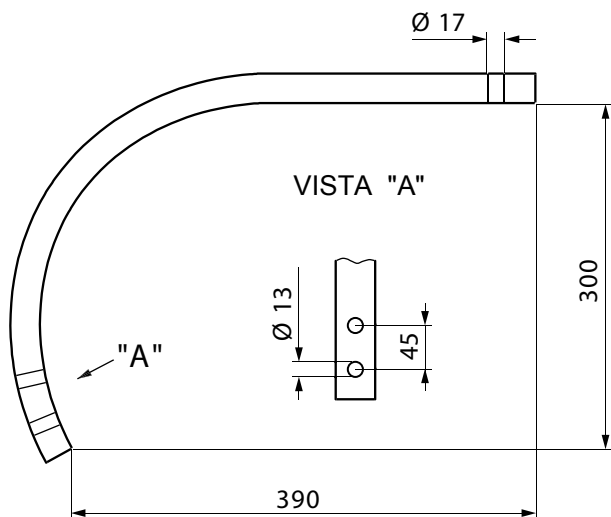

CH32SVV

32x32

4,950

CH4520SVV

45x20

5,100

Codice Nr.
 Ref. Nr.
 Re. Nr.
 Ref. Nr.
 Tutti i modelli sono di nostra produzione e non originali.
 All models are of our manufacture and are not original.
 Alle unsere Landwirtschaftliche erzeugnisse sind unsere produktion und sind nicht original.
 Tous les modèles sont notre production et ne sont pas des produits d'origine.
 Все модели нашего производства и не являются оригинальными.

Peso
 Weight
 Gewicht
 Poids
 Codice Nr.
 Ref. Nr.
 Re. Nr.
 Ref. Nr.
 N.B. Pesi e misure sopra descritti sono puramente indicativi.
 N.B. The above weights and dimensions are given for reference only.
 N.B. Die obengenannten Gewichte und Abmessungen sind richtungsweisend.
 N.B. Les poids et les dimensions indiqués ci-dessus sont donnés à titre indicatif.
 N.B. Указанные вес и размеры, являются ориентировочными.

Sezione
 Section
 Abschnitt
 Section
 © La riproduzione anche parziale del presente catalogo è vietata.

MOLLE
Cultivator tines
Feingrubberzinken
Dents pour vibroculteurs
Культиваторные стойки



Codice Nr. Ref. Nr. Re. Nr. Ref. Nr. Код №	Sezione Section Abschnitt Section Размеры mm	Peso Weight Gewicht Poids Bec kg	Codice Nr. Ref. Nr. Re. Nr. Ref. Nr. Код №	Sezione Section Abschnitt Section Размеры mm	Peso Weight Gewicht Poids Bec kg
CH3040SVV	40x30	8,500	CH40SVV	40x40	11

ATTACCO COMPLETO PER MOLLA
CHISEL

Complete support for chisel spring
 Kompl. Stütze für chisel-feder
 Bride complete pour chisel
 Стремя для чизельной стойки

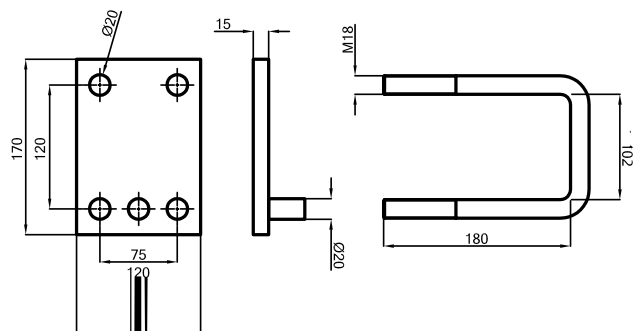

Codice Nr. Ref. Nr. Re. Nr. Ref. Nr. Код №	Sezione Section Abschnitt Section Размеры mm	Piastre Plate Platte Plaque Профиль mm	Bullone Bolt Schrauben Boulon Болт mm	Peso Weight Gewicht Poids Bec kg
ACC	tub. 100	—	—	4,40

204

Tutti i modelli sono di nostra produzione e non originali.
 All models are of our manufacture and are not original.
 Alle unsere Landwirtschaftliche erzeugnisse sind unsere produktion und sind nicht original.
 Tous les modèles sont notre production et ne sont pas des produits d'origine.
 Все модели нашего производства и не являются оригинальными.

N.B. Pesi e misure sopra descritti sono puramente indicativi.
 N.B. The above weights and dimensions are given for reference only.
 N.B. Die obengenannten Gewichte und Abmessungen sind richtungweisend.
 N.B. Les poids et les dimensions indiqués ci-dessus sont donnés à titre indicatif.
 N.B. Указанные вес и размеры, являются ориентировочными.

© La riproduzione anche parziale del presente catalogo è vietata.

MOLLE
Cultivator tines
Feingrubberzinken
Dents pour vibroculteurs
Культиваторные стойки



Codice Eurozappa
Eurozappa Ref. Nr.
Eurozappa Re. Nr.
Eurozappa Ref. Nr.
Код Еврозаппа №

Sezione
Section
Abschnitt
Section
Размеры
A x B mm

Molla
Tine
Kulturreggenzinken
Dents pour vibroculteur
Культиваторная стойка
mm

Bullone
Bolt
Schrauben
Boulon
Болт

Peso
Weight
Gewicht
Poids
Вес
kg

**VOMERE REVERSIBILE
PER MOLLA CHISEL**

Reversible point for chisel spring
Deutsches Schartyp für Chisel Feder
Reversible soc pour chisel
Двусторонняя лапа для чизельной стойки

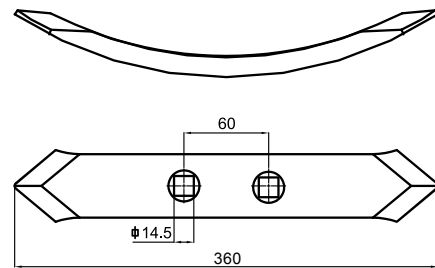

800019

55x15x360

—

2,470

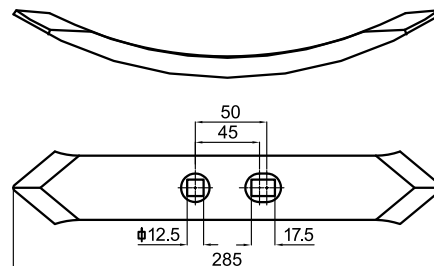

800042

60x12x285

—

1,400

VOMERE DOPPIO CUORE

Double duck-foot chisel point
Deutsches Schartyp für Chisel Feder
Soc doublet coeur pour chisel
Двусторонняя лапа для чизельной стойки

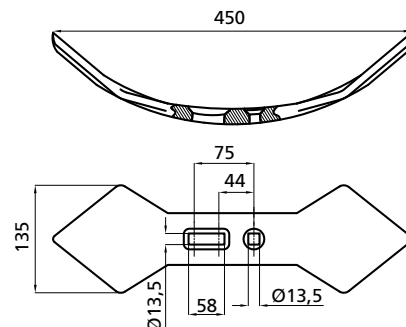

800058

65x15x440

—

3,400

Tutti i modelli sono di nostra produzione e non originali.
All models are of our manufacture and are not original.
Alle unsere Landwirtschaftliche erzeugnisse sind unsere produktion und sind nicht original.
Tous les modèles sont notre production et ne sont pas des produits d'origine.
Все модели нашего производства и не являются оригинальными.

N.B. Pesi e misure sopra descritti sono puramente indicativi.
N.B. The above weights and dimensions are given for reference only.
N.B. Die obengenannten Gewichte und Abmessungen sind richtungsweisend.
N.B. Les poids et les dimensions indiqués ci-dessus sont donnés à titre indicatif.
N.B. Указанные вес и размеры, являются ориентировочными.

© La riproduzione
anche parziale
del presente catalogo
è vietata.



MOLLA COLTIVATORE

Cultivator spring
 Grubberzinke
 Dent cultivateur
 Культиваторная стойка

C12SVV

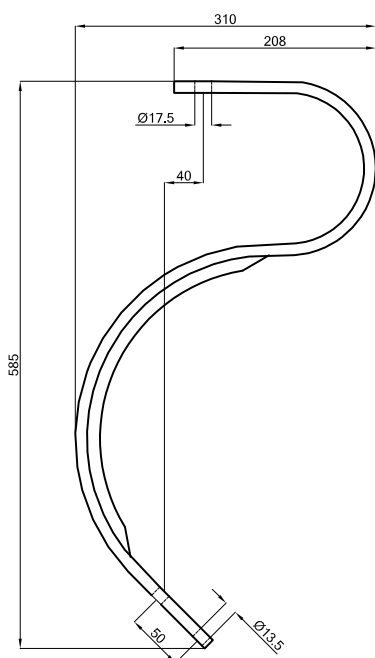

C20SVV

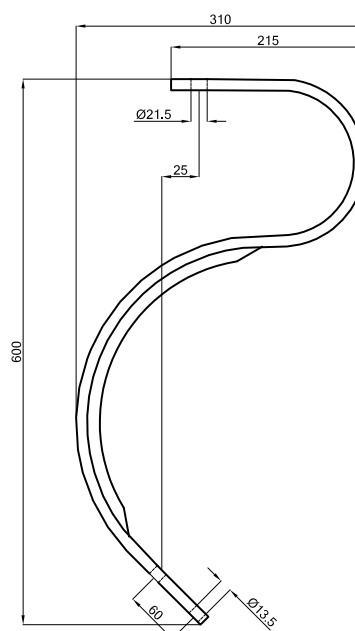

Codice Nr. Ref. Nr. Re. Nr. Ref. Nr. Код №	Sezione Section Abschnitt Section Размеры mm	Vomere Point Schar Soc Лана mm	Peso Weight Gewicht Poids Bec kg
C12SVV	50×12	—	4,15
C12CVV	55×12	800042	9,70
C12CVVR (C12CVV + RC12V)	50×12	800042	5,6
C16SVV	50×16	—	5,40
C16CVV	50×16	800042	6,9
C20SVV	55×20	—	7,55
C20CVV	55×20	800042	9,70

MOLLE
Cultivator tines
Feingrubberzinken
Dents pour vibroculteurs
Культиваторные стойки



Codice Eurozappa
Eurozappa Ref. Nr.
Eurozappa Re. Nr.
Eurozappa Ref. Nr.
Код Еврозатпа №

Sezione
Section
Abschnitt
Section
Размеры
A x B mm

Molla
Tine
Kulturreggenzinken
Dents pour vibroculteur
Культиваторная стойка
mm

Bullone
Bolt
Schrauben
Boulon
Болт

Peso
Weight
Gewicht
Poids
Вес
kg

RINFORZO PER COLTIVATORE

Support for cultivator
Verstärkung für Grubber
Renfort pour coltivateur
Подпружинник для стойки

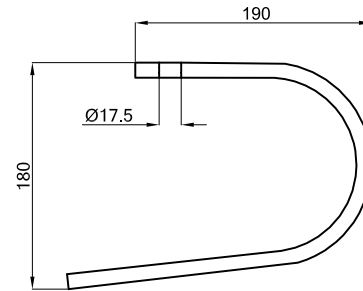

RC12V

50x12

—

2,60 ca.

VOMERE REVERSIBILE PER COLTIVATORE

Reversible point for cultivator
Schare für Grubberzinke
Réversible soc pour coltivateur
Двусторонняя лапа для культиваторной стойки

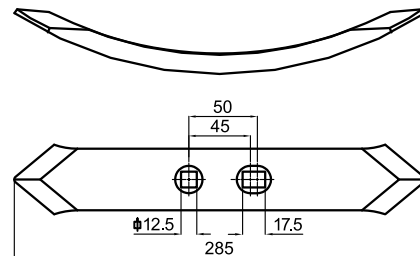

800042

60x12x285

—

1,400

ATTACCO PER COLTIVATORE

Support for cultivator
Grubberzinke
Bride pour coltivateur
Стремя для культиваторной стойки

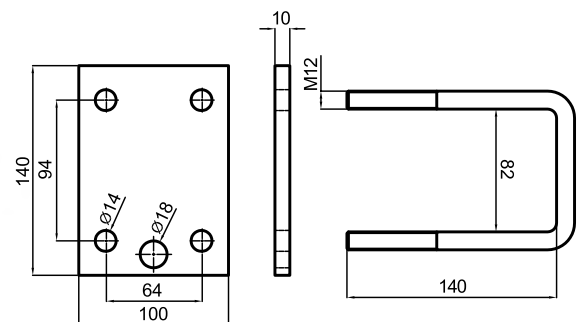

AC12

tub. 80

—

1,73

AC16

tub. 80

—

1,73

Tutti i modelli sono di nostra produzione e non originali.
All models are of our manufacture and are not original.
Alle unsere Landwirtschaftliche erzeugnisse sind unsere produktion und sind nicht original.
Tous les modèles sont notre production et ne sont pas des produits d'origine.
Все модели нашего производства и не являются оригинальными.

N.B. Pesi e misure sopra descritti sono puramente indicativi.
N.B. The above weights and dimensions are given for reference only.
N.B. Die obengenannten Gewichte und Abmessungen sind richtungsweisend.
N.B. Les poids et les dimensions indiqués ci-dessus sont donnés à titre indicatif.
N.B. Указанные вес и размеры, являются ориентировочными.

© La riproduzione
anche parziale
del presente catalogo
è vietata.

MOLLE
Cultivator tines
Feingrubberzinken
Dents pour vibroculteurs
Культиваторные стойки



Codice Nr. Ref. Nr. Re. Nr. Ref. Nr. Код №	Sezione Section Abschnitt Section Размеры mm	Vomere Point Schar Soc Лана mm	Peso Weight Gewicht Poids Вес kg
--	---	---	---

BULLONE TSQ CON DADO

Screw TSQ with bolt
 Schraube TSQ mit mutter
 Boulon TSQ complet
 Болт TSQ с гайкой

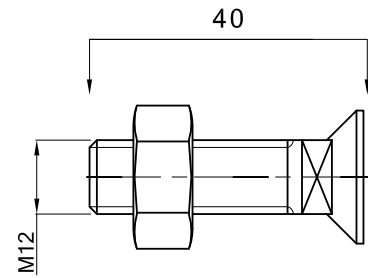

B1240

12×40

—

0,055

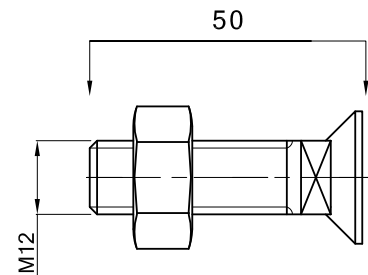

B1250

12×50

—

0,065

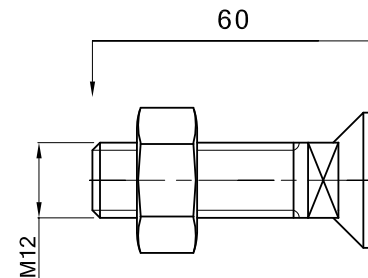

B1260

12×60

—

0,075

MOLLE
Cultivator tines
Feingrubberzinken
Dents pour vibroculteurs
Культиваторные стойки



Codice Nr. Ref. Nr. Re. Nr. Ref. Nr. Код №	Sezione Section Abschnitt Section Размеры mm	Vomere Point Schar Soc Лана mm	Peso Weight Gewicht Poids Вес kg
--	---	---	---

MOLLA DOPPIA SPIRA 20x20

Square spring double turn
 Vierkantige Zinke mit Doppelwicklung (lange Ausführung)
 Ressort carré doublet spire
 Пружинная стойка с двойным витком



ESEMPIO SINISTRA

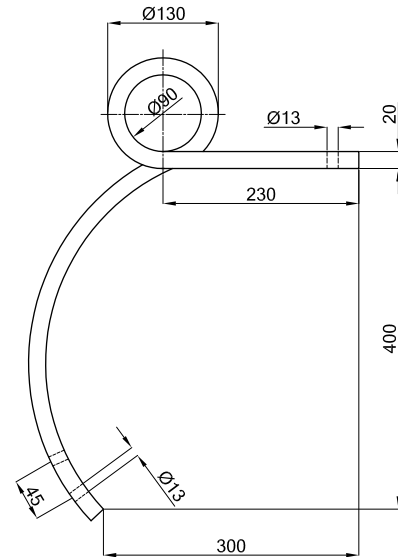

Q20SVV	Molla senza vomere	20x20	—	4,46
--------	--------------------	-------	---	------

MOLLA DOPPIA SPIRA 20x20
DRITTA

Straight square-spring double turn
 Gerade vierkantige Zinke mit Doppelwicklung
 Dent carré droite doublet spire
 Пружинная стойка прямая с двойным витком

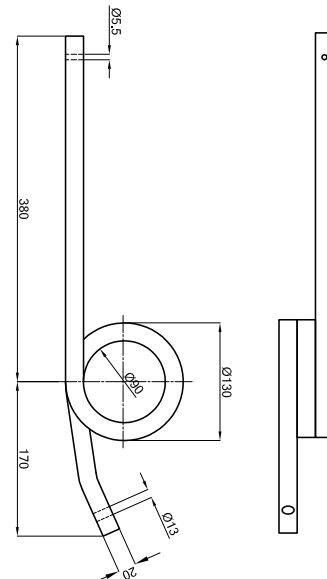

Q20D	Molla senza vomere	20x20	—	3,68
------	--------------------	-------	---	------

Tutti i modelli sono di nostra produzione e non originali.
 All models are of our manufacture and are not original.
 Alle unsere Landwirtschaftliche erzeugnisse sind unsere produktion und sind nicht original.
 Tous les modèles sont notre production et ne sont pas des produits d'origine.
 Все модели нашего производства и не являются оригинальными.

N.B. Pesi e misure sopra descritti sono puramente indicativi.
 N.B. The above weights and dimensions are given for reference only.
 N.B. Die obengenannten Gewichte und Abmessungen sind richtungsweisend.
 N.B. Les poids et les dimensions indiqués ci-dessus sont donnés à titre indicatif.
 N.B. Указанные вес и размеры, являются ориентировочными.

© La riproduzione
 anche parziale
 del presente catalogo
 è vietata.

MOLLE
Cultivator tines
Feingrubberzinken
Dents pour vibroculteurs
Культиваторные стойки



Codice Nr. Ref. Nr. Re. Nr. Ref. Nr. Код №	Sezione Section Abschnitt Section Размеры mm	Vomere Point Schar Soc Лана mm	Peso Weight Gewicht Poids Вес kg
--	---	---	---

**MOLLA DOPPIA SPIRA 20×20
 DRITTA**

Straight square-spring double turn
 Gerade vierkantige Zinke mit Doppelwicklung
 Dent carré droite doublet spire
 Пружинная стойка прямая с двойным витком

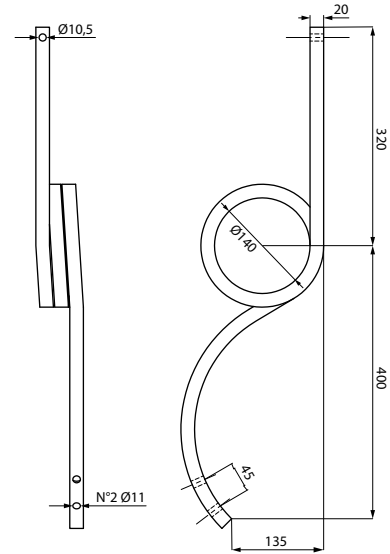

Q20SVVDRITTA	Molla senza vomere	20×20	—	5,48
--------------	--------------------	-------	---	------

MOLLA DOPPIA SPIRA 25×25

Square spring double turn
 Vierantige Zinke mit Doppelwicklung
 Ressort carré doublet spire
 Пружинная стойка с двойным витком



ESEMPIO SINISTRA

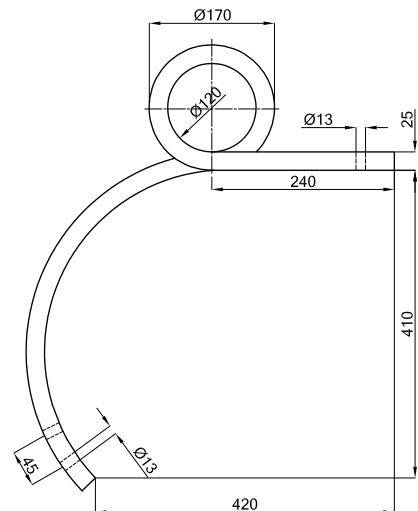

Q25SVV	Molla senza vomere	25×25	—	8
Q25CVV	Molla con vomere	25×25	800006	9,1

MOLLE
Cultivator tines
Feingrubberzinken
Dents pour vibroculteurs
Культиваторные стойки



Codice Nr. Ref. Nr. Re. Nr. Ref. Nr. Код №	Sezione Section Abschnitt Section Размеры mm	Vomere Point Schar Soc Лана mm	Peso Weight Gewicht Poids Bec kg
--	---	---	---

MOLLA DOPPIA SPIRA 25x25
TIPO ALTO

High square spring
 Vierantige Zinke mit doppelter Wicklung (lange Ausführung)
 Ressort carré doublet spire longue
 Пружинная стойка высокая



ESEMPIO SINISTRA

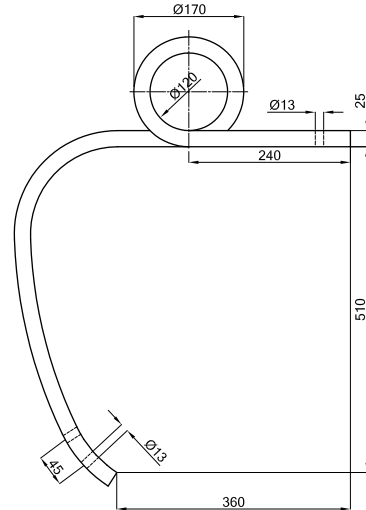

Q25ASVV	Molla senza vomere	25x25	—	9,5
Q25ACVV	Molla con vomere	25x25	800006	10,6

MOLLA DOPPIA SPIRA 26x26

Square spring double turn
 Vierkantige Zinke mit Doppelwicklung
 Ressort carré doublet spire
 Пружинная стойка с двойным витком

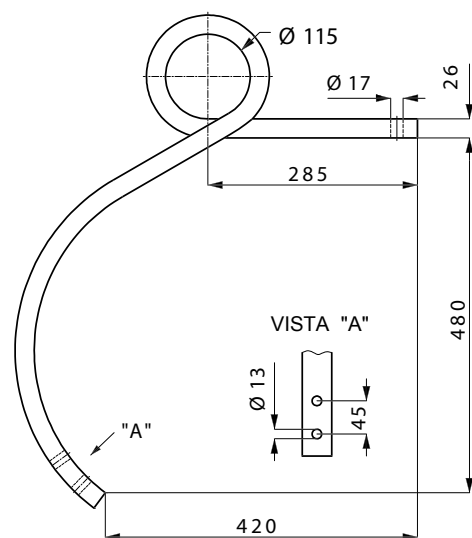

Q26SVV	Molla senza vomere	26x26	—	9,50
--------	--------------------	-------	---	------

Tutti i modelli sono di nostra produzione e non originali.
 All models are of our manufacture and are not original.
 Alle unsere Landwirtschaftliche erzeugnisse sind unsere produktion und sind nicht original.
 Tous les modèles sont notre production et ne sont pas des produits d'origine.
 Все модели нашего производства и не являются оригинальными.

N.B. Pesi e misure sopra descritti sono puramente indicativi.
 N.B. The above weights and dimensions are given for reference only.
 N.B. Die obengenannten Gewichte und Abmessungen sind richtungsweisend.
 N.B. Les poids et les dimensions indiqués ci-dessus sont donnés à titre indicatif.
 N.B. Указанные вес и размеры, являются ориентировочными.

© La riproduzione
 anche parziale
 del presente catalogo
 è vietata.

MOLLE
Cultivator tines
Feingrubberzinken
Dents pour vibroculteurs
Культиваторные стойки



Codice Nr. Ref. Nr. Re. Nr. Ref. Nr. Код №	Sezione Section Abschnitt Section Размеры mm	Vomere Point Schar Soc Лана mm	Peso Weight Gewicht Poids Bec kg
--	---	---	---

MOLLA DOPPIA SPIRA 27x27

Square spring double turn
 Vierkantige Zinke mit Doppelwicklung
 Ressort carré doublet spire
 Пружинная стойка с двойным витком

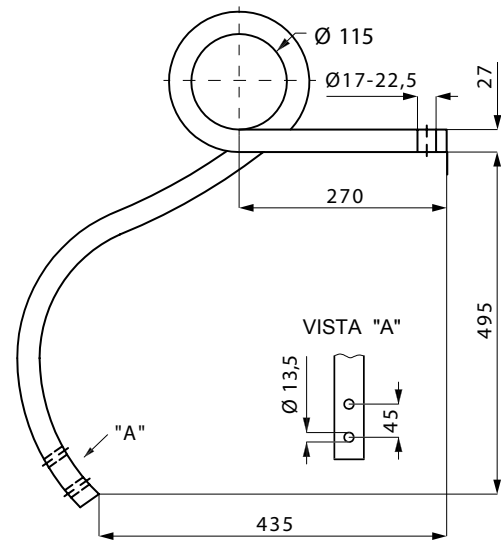

Q27SVV	Molla senza vomere	27x27	—	10,5
--------	--------------------	-------	---	------

MOLLA DENTE QUADRO 30x30

Square S-tine 30x30
 Quadrat zinke 30x30
 Dent carré 30x30
 Стойка пружинная 30x30

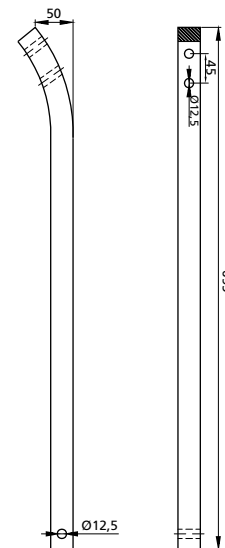

DQ30SVV	Molla senza vomere	30x30	—	4,8
DQ30CVV	Molla con vomere	30x30	800006	4,8

212

Tutti i modelli sono di nostra produzione e non originali.
 All models are of our manufacture and are not original.
 Alle unsere Landwirtschaftliche erzeugnisse sind unsere produktion und sind nicht original.
 Tous les modèles sont notre production et ne sont pas des produits d'origine.
 Все модели нашего производства и не являются оригинальными.

N.B. Pesi e misure sopra descritti sono puramente indicativi.
 N.B. The above weights and dimensions are given for reference only.
 N.B. Die obengenannten Gewichte und Abmessungen sind richtungsweisend.
 N.B. Les poids et les dimensions indiqués ci-dessus sont donnés à titre indicatif.
 N.B. Указанные вес и размеры, являются ориентировочными.

© La riproduzione anche parziale del presente catalogo è vietata.

MOLLE
Cultivator tines
Feingrubberzinken
Dents pour vibroculteurs
Культиваторные стойки



Codice Nr. Ref. Nr. Re. Nr. Ref. Nr. Код №	Sezione Section Abschnitt Section Размеры mm	Vomere Point Schar Soc Лана mm	Peso Weight Gewicht Poids Вес kg
--	---	---	---

MOLLA DOPPIA SPIRA 30x30

Square spring double turn
 Vierkantige Zinke mit Doppelwicklung
 Ressort carré doublet spire
 Пружинная стойка с двойным витком



ESEMPIO SINISTRA

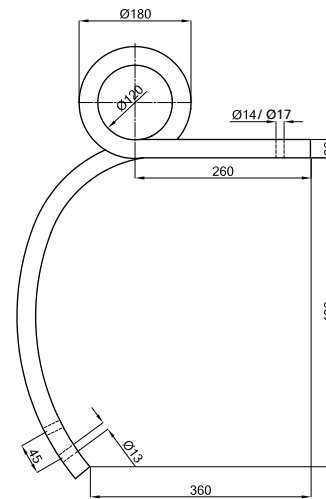

Q30SVV	Molla senza vomere	30x30	—	12,5
Q30CVV	Molla con vomere	30x30	800006	13,6

MOLLA DOPPIA SPIRA 30x30
TIPO ALTO

High square spring
 Vierkantige Zinke mit Doppelwicklung (lange Ausführung)
 Ressort carré doublet spire longue
 Пружинная стойка высокая



ESEMPIO SINISTRA

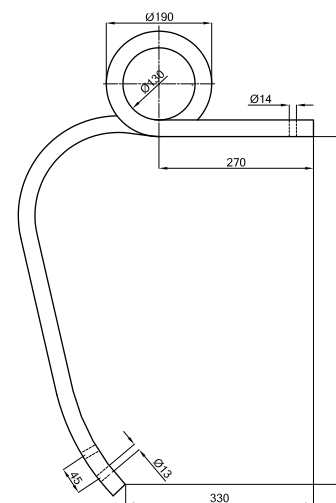

Q30ASVV	Molla senza vomere	30x30	—	14
Q30ACVV	Molla con vomere	30x30	800006	15,1

Tutti i modelli sono di nostra produzione e non originali.
 All models are of our manufacture and are not original.
 Alle unsere Landwirtschaftliche erzeuignisse sind unsere produktion und sind nicht original.
 Tous les modèles sont notre production et ne sont pas des produits d'origine.
 Все модели нашего производства и не являются оригинальными.

N.B. Pesi e misure sopra descritti sono puramente indicativi.
 N.B. The above weights and dimensions are given for reference only.
 N.B. Die obengenannten Gewichte und Abmessungen sind richtungsweisend.
 N.B. Les poids et les dimensions indiqués ci-dessus sont donnés à titre indicatif.
 N.B. Указанные вес и размеры, являются ориентировочными.

© La riproduzione
 anche parziale
 del presente catalogo
 è vietata.

MOLLE
Cultivator tines
Feingrubberzinken
Dents pour vibroculteurs
Культиваторные стойки



Codice Nr. Ref. Nr. Re. Nr. Ref. Nr. Код №	Sezione Section Abschnitt Section Размеры mm	Vomere Point Schar Soc Лана mm	Peso Weight Gewicht Poids Вес kg
--	---	---	---

MOLLA DOPPIA SPIRA 32x32

Square spring double turn
 Vierkantige Zinke mit Doppelwicklung
 Ressort carré doublet spire
 Пружинная стойка с двойным витком

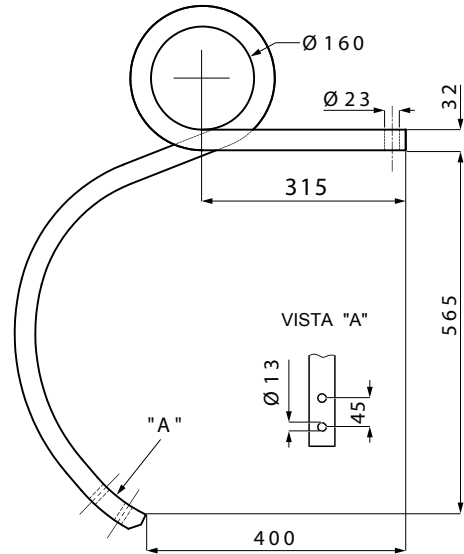

Q32SVV	Molla senza vomere	32x32	—	16,950
--------	--------------------	-------	---	--------

MOLLA DOPPIA SPIRA 35x35

Square spring double turn
 Vierkantige Zinke mit Doppelwicklung (lange Ausführung)
 Ressort carré doublet spire
 Пружинная стойка с двойным витком



ESEMPIO SINISTRA

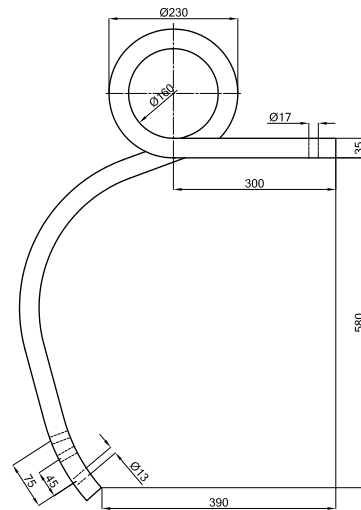

Q35SVV	Molla senza vomere	35x35	—	20,85
Q35CVV T60	Molla con vomere	35x35	800058	24,10
Q35CVV Q400	Molla con vomere	35x35	800072	23,40

MOLLE
Cultivator tines
Feingrubberzinken
Dents pour vibroculteurs
Культиваторные стойки



Codice Nr. Ref. Nr. Re. Nr. Ref. Nr. Код №	Sezione Section Abschnitt Section Размеры mm	Vomere Point Schar Soc Лана mm	Peso Weight Gewicht Poids Bec kg
--	---	---	---

MOLLA DOPPIA SPIRA 35x35
TIPO ALTO

Square spring double turn
 Vierkantige Zinke mit Doppelwicklung (lange Ausführung)
 Ressort carré doublet spire
 Пружинная стойка с двойным витком

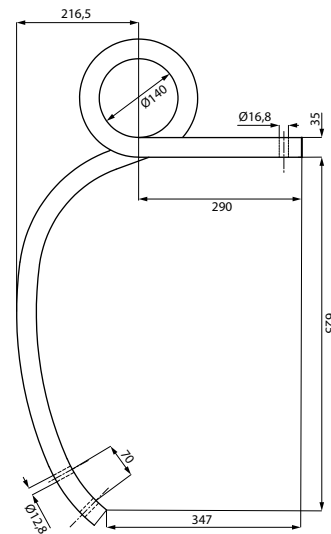

Q35ASVV

Molla senza vomere

35x35

—

21,30

MOLLA DOPPIA SPIRA 35x35
TIPO GRAND

Square spring double turn
 Vierkantige Zinke mit Doppelwicklung
 Ressort carré doublet spire
 Пружинная стойка с двойным витком

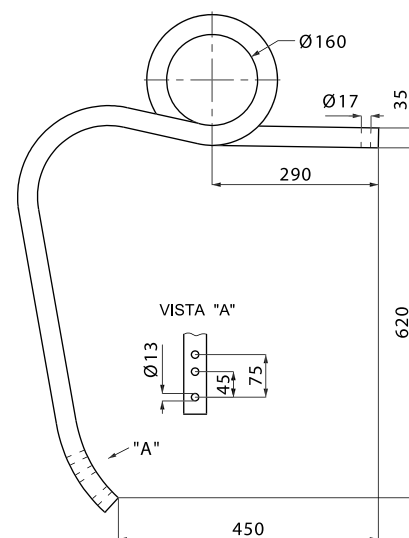

Q35GRANDSVV

Molla senza vomere

35x35

—

22,6

Tutti i modelli sono di nostra produzione e non originali.
 All models are of our manufacture and are not original.
 Alle unsere Landwirtschaftliche erzeugnisse sind unsere produktion und sind nicht original.
 Tous les modèles sont notre production et ne sont pas des produits d'origine.
 Все модели нашего производства и не являются оригинальными.

N.B. Pesi e misure sopra descritti sono puramente indicativi.
 N.B. The above weights and dimensions are given for reference only.
 N.B. Die obengenannten Gewichte und Abmessungen sind richtungsweisend.
 N.B. Les poids et les dimensions indiqués ci-dessus sont donnés à titre indicatif.
 N.B. Указанные вес и размеры, являются ориентировочными.

© La riproduzione
 anche parziale
 del presente catalogo
 è vietata.

MOLLE
Cultivator tines
Feingrubberzinken
Dents pour vibroculteurs
Культиваторные стойки



Codice Nr. Ref. Nr. Re. Nr. Ref. Nr. Код №	Sezione Section Abschnitt Section Размеры mm	Fori Holes Löcher Trous Отверстия mm	Peso Weight Gewicht Poids Вес kg
--	---	---	---

MOLLA DOPPIA SPIRA 40x40

Square spring double turn
 Vierkantige Zinke mit Doppelwicklung
 Ressort carré doublet spire
 Пружинная стойка с двойным витком

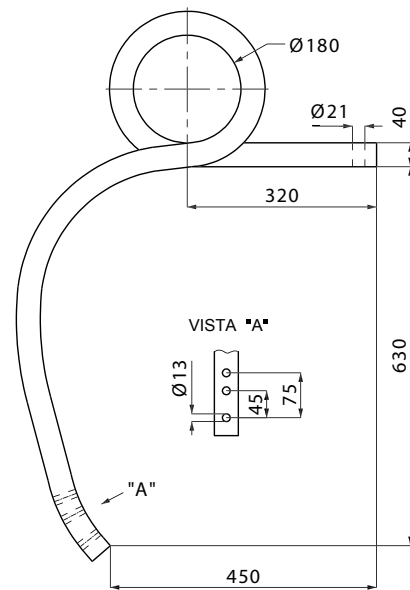

Q40GRANDSVV	Molla senza vomere	40x40	—	30,2
-------------	--------------------	-------	---	------

**VOMERE DOPPIO CUORE
 PER MOLLA QUADRA**

Double duck-foot for square-spring
 Schar für Vierkantigezinke
 Soc doublet coeur pour dent carré
 Двусторонняя лапа для пружинной стойки

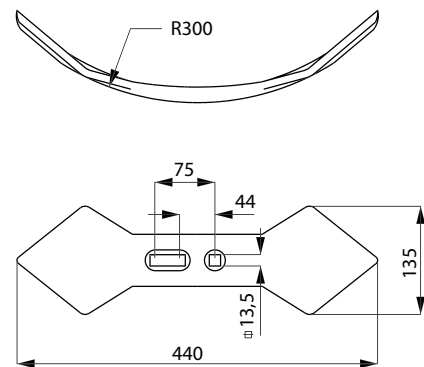

800058	135x440	13,5	3,400
800065	135x440	15	3,400

216





Tutti i modelli sono di nostra produzione e non originali.
 All models are of our manufacture and are not original.
 Alle unsere Landwirtschaftliche erzeugnisse sind unsere produktion und sind nicht original.
 Tous les modèles sont notre production et ne sont pas des produits d'origine.
 Все модели нашего производства и не являются оригинальными.

N.B. Pesi e misure sopra descritti sono puramente indicativi.
 N.B. The above weights and dimensions are given for reference only.
 N.B. Die obengenannten Gewichte und Abmessungen sind richtungsweisend.
 N.B. Les poids et les dimensions indiqués ci-dessus sont donnés à titre indicatif.
 N.B. Указанные вес и размеры, являются ориентировочными.

© La riproduzione anche parziale del presente catalogo è vietata.

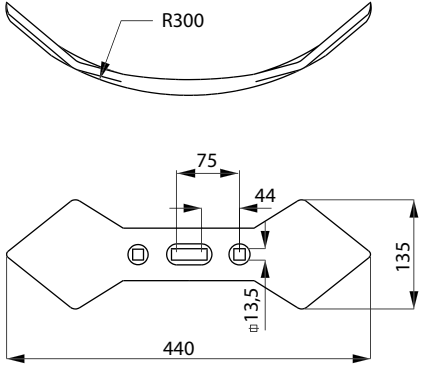
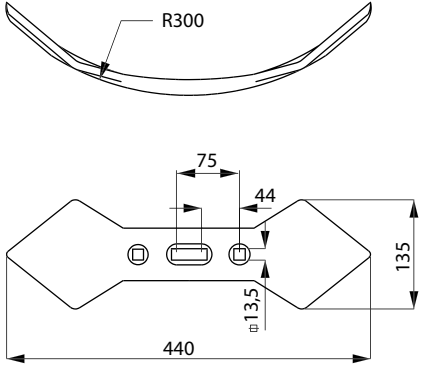
MOLLE
Cultivator tines
Feingrubberzinken
Dents pour vibroculteurs
Культиваторные стойки

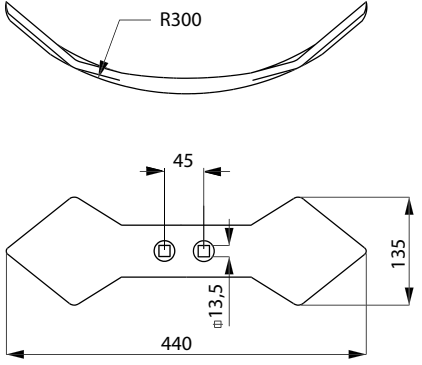
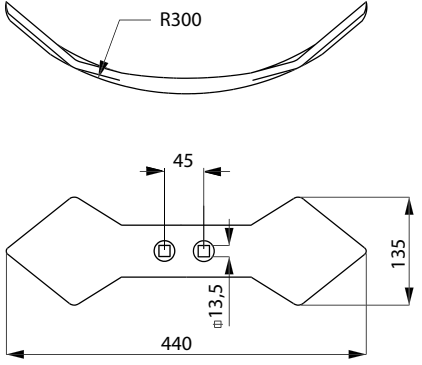

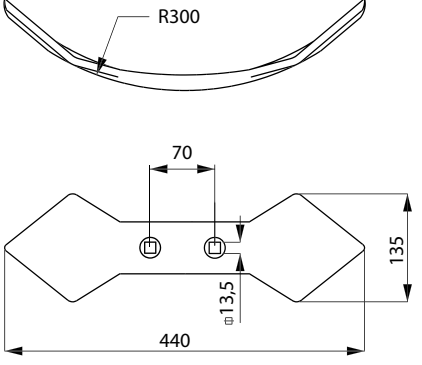
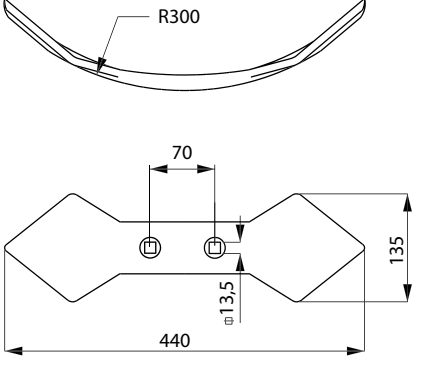
Codice Nr. Ref. Nr. Re. Nr. Ref. Nr. Код №	Sezione Section Abschnitt Section Размеры mm	Fori Holes Löcher Trous Отверстия mm	Peso Weight Gewicht Poids Вес gr
			<p>800059 135x440 13,5 3,400</p>
			<p>800060 135x440 13,5 3,400</p>
			<p>800061 135x440 13,5 3,400</p>
<p>800064</p>	<p>135x440</p>	<p>15</p>	<p>3,400</p>

Tutti i modelli sono di nostra produzione e non originali.
 All models are of our manufacture and are not original.
 Alle unsere Landwirtschaftliche erzeugnisse sind unsere produktion und sind nicht original.
 Tous les modèles sont notre production et ne sont pas des produits d'origine.
 Все модели нашего производства и не являются оригинальными.

N.B. Pesi e misure sopra descritti sono puramente indicativi.
 N.B. The above weights and dimensions are given for reference only.
 N.B. Die obengenannten Gewichte und Abmessungen sind richtungsweisend.
 N.B. Les poids et les dimensions indiqués ci-dessus sont donnés à titre indicatif.
 N.B. Указанные вес и размеры, являются ориентировочными.

© La riproduzione anche parziale del presente catalogo è vietata.

MOLLE
Cultivator tines
Feingrubberzinken
Dents pour vibroculteurs
Культиваторные стойки



Codice Nr. Ref. Nr. Re. Nr. Ref. Nr. Код №	Sezione Section Abschnitt Section Размеры mm	Peso Weight Gewicht Poids Bec kg	Codice Nr. Ref. Nr. Re. Nr. Ref. Nr. Код №	Sezione Section Abschnitt Section Размеры mm	Peso Weight Gewicht Poids Bec kg
--	---	---	--	---	---

VOMERE A LANCIA
PER MOLLA QUADRA

Duck foot point for square-spring
Breitschar für Vierkantigezinke
Soc à coeur pour dent carré
Стрельчатая лапа для пружинной стойки

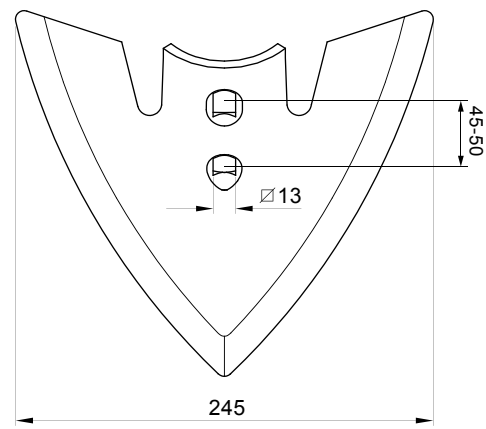
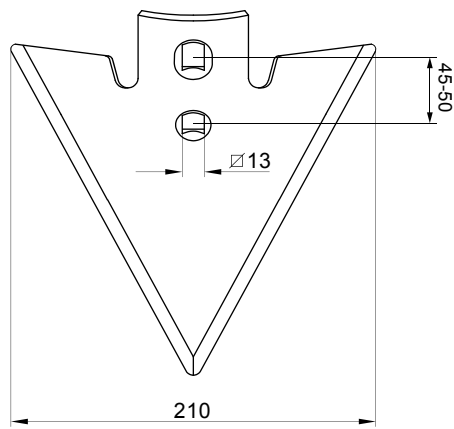

550192	210×6	1,080	550193	245×6	1,200
---------------	--------------	--------------	---------------	--------------	--------------

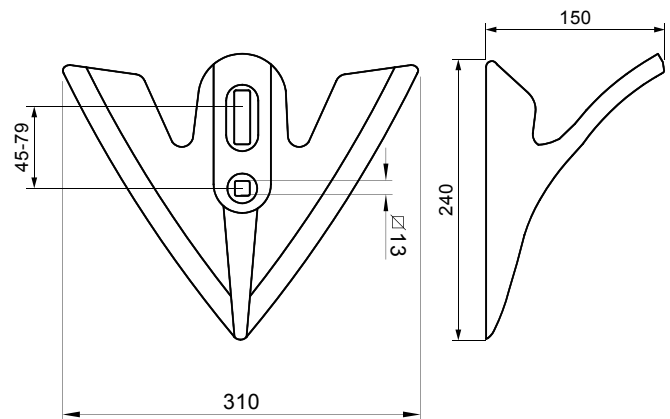
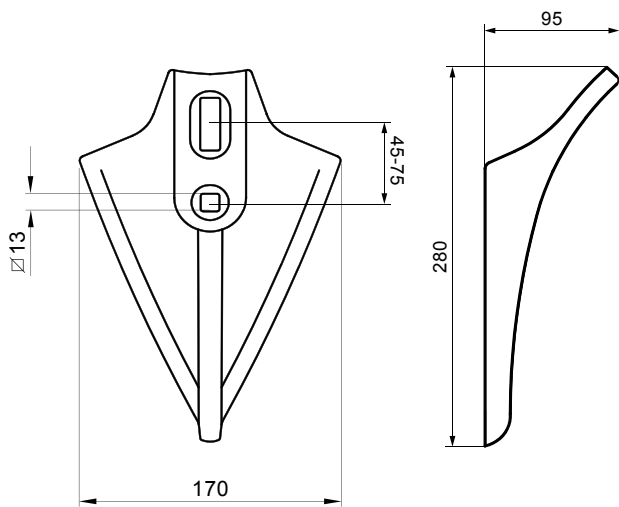

550275	—	2,700	550276	—	3,800
---------------	----------	--------------	---------------	----------	--------------

MOLLE
Cultivator tines
Feingrubberzinken
Dents pour vibroculteurs
Культиваторные стойки



Codice Nr. Ref. Nr. Re. Nr. Ref. Nr. Код №	Sezione Section Abschnitt Section Размеры mm	Vomere Point Schar Soc Лана mm	Peso Weight Gewicht Poids Bec kg
--	---	---	---

**VOMERE REVERSIBILE
 PER MOLLA QUADRA**

Reversible point for square-spring
 Umgekehrte Schar für vierkantige Zinke
 Réversible soc pour dent carré
 Двусторонняя лапа для пружинной стойки

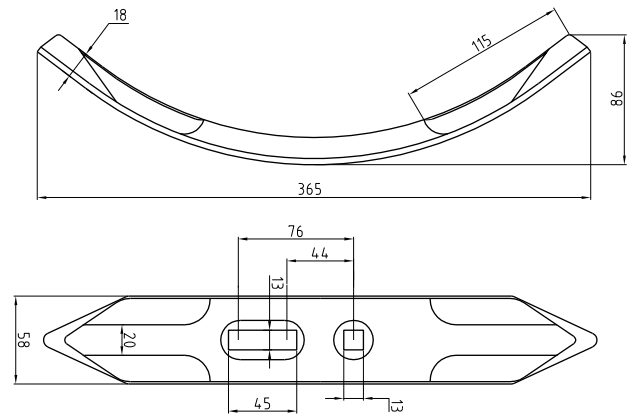

550226

55x15

—

2,150

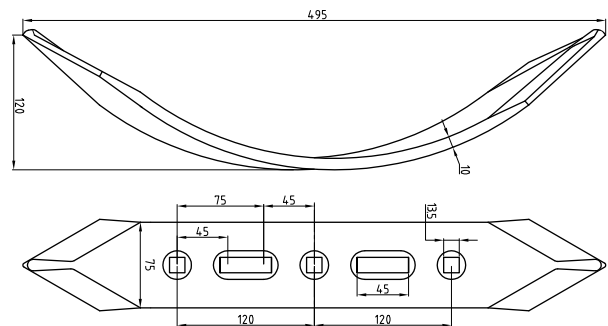

800013

75x10

—

2,660

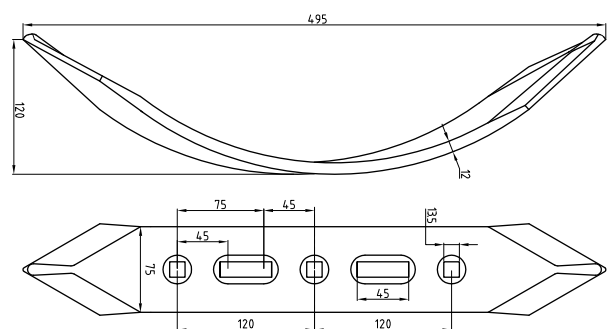

800097

75x12

—

3,300

Tutti i modelli sono di nostra produzione e non originali.
 All models are of our manufacture and are not original.
 Alle unsere Landwirtschaftliche erzeugnisse sind unsere produktion und sind nicht original.
 Tous les modèles sont notre production et ne sont pas des produits d'origine.
 Все модели нашего производства и не являются оригинальными.

N.B. Pesi e misure sopra descritti sono puramente indicativi.
 N.B. The above weights and dimensions are given for reference only.
 N.B. Die obengenannten Gewichte und Abmessungen sind richtungsweisend.
 N.B. Les poids et les dimensions indiqués ci-dessus sont donnés à titre indicatif.
 N.B. Указанные вес и размеры, являются ориентировочными.

© La riproduzione
 anche parziale
 del presente catalogo
 è vietata.

MOLLE
Cultivator tines
Feingrubberzinken
Dents pour vibroculteurs
Культиваторные стойки



Codice Eurozappa
Eurozappa Ref. Nr.
Eurozappa Re. Nr.
Eurozappa Ref. Nr.
Код Еврозаппа №

Sezione
Section
Abschnitt
Section
Размеры
mm

Vomere
Point
Schar
Soc
Лана
mm

Peso
Weight
Gewicht
Poids
Bec
gr

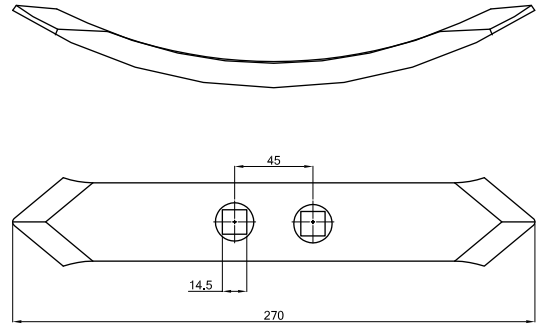

800006

VQ

40x16

—

1,130

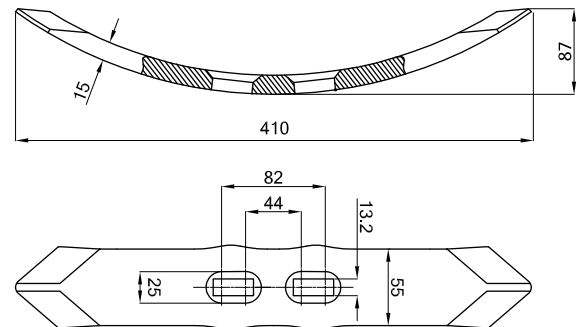

800072

VQ400

55x15x410

—

2,500

BULLONE CON DADO PER
VOMERE MOLLA QUADRA TSQ

Screw with bolt for square-spring point
Scharschraube für vierkantige Zinke
Boulon complet pour soc de dent carré
Болт с гайкой для лапы пружинной стойки

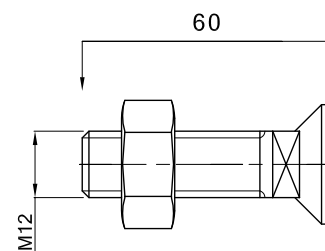

B1260

12x60

—

0,075

220

Tutti i modelli sono di nostra produzione e non originali.
All models are of our manufacture and are not original.
Alle unsere Landwirtschaftliche erzeugnisse sind unsere produktion und sind nicht original.
Tous les modèles sont notre production et ne sont pas des produits d'origine.
Все модели нашего производства и не являются оригинальными.

N.B. Pesi e misure sopra descritti sono puramente indicativi.
N.B. The above weights and dimensions are given for reference only.
N.B. Die obengenannten Gewichte und Abmessungen sind richtungweisend.
N.B. Les poids et les dimensions indiqués ci-dessus sont donnés à titre indicatif.
N.B. Указанные вес и размеры, являются ориентировочными.

© La riproduzione anche parziale del presente catalogo è vietata.

MOLLE
Cultivator tines
Feingrubberzinken
Dents pour vibroculteurs
Культиваторные стойки



Codice Nr. Ref. Nr. Re. Nr. Ref. Nr. Код №	Sezione Section Abschnitt Section Размеры mm	Vomere Point Schar Soc Лана mm	Peso Weight Gewicht Poids Вес kg
--	---	---	---

**ATTACCO MOLLA QUADRA
 DA 25/30 mm COMPLETO**

Complete support for square-spring 25×25 / 30×30 mm
 Komplette Stütze für vierkantige Zinke 25×25 / 30×30 mm
 Bride complete pour ressort carré 25×25 / 30×30 mm
 Стремя в комплекте для пружинной стойки 25×25 / 30×30 мм

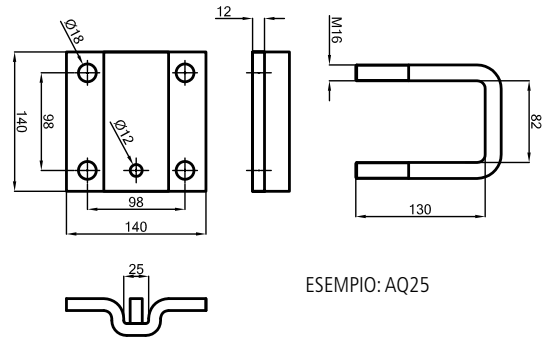

ESEMPIO: AQ25

AQ25 PQ25 + CQ16CD Piastra + cavallotti + dadi	tub. 80	—	3
AQ30 PQ30 + CQ16CD Piastra + cavallotti + dadi	tub. 80	—	3

**ATTACCO MOLLA QUADRA
 DA 30/35 mm COMPLETO**

Complete support for square-spring 30×30 / 35×35 mm
 Komplette Stütze für vierkantige Zinke 30×30 / 35×35 mm
 Bride complete pour ressort carré 30×30 / 35×35 mm
 Стремя в комплекте для пружинной стойки 30×30 / 35×35 мм

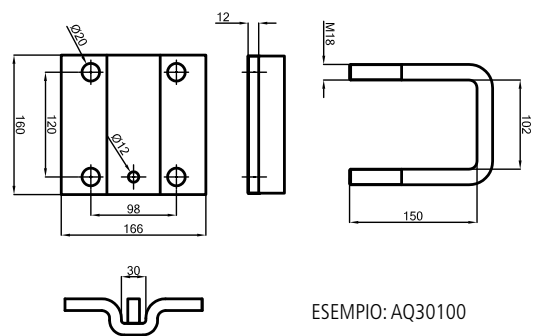

ESEMPIO: AQ30100

AQ30100 PQ30 + CQ18CD Piastra + cavallotti + dadi	tub. 100	—	3,1
AQ35 PQ35 + CQ18CD Piastra + cavallotti + dadi	tub.100	—	3,3

MOLLE
Cultivator tines
Feingrubberzinken
Dents pour vibroculteurs
Культиваторные стойки



Codice Nr. Ref. Nr. Re. Nr. Ref. Nr. Код №	Sezione Section Abschnitt Section Размеры mm	Piastre Plate Platte Plaque Профиль mm	Bullone Bolt Schrauben Boulon Болт mm	Peso Weight Gewicht Poids Вес kg
--	---	---	--	---

**STAFFA D'ATTACCO COMPLETA
 PER QUADRA 25x25**

Complete support for square-spring 25x25
 Stütze für vierkantige Zinke 25x25
 Bride complet pour ressort carré 25x25
 Стремя в комплекте для пружинной стойки 25x25

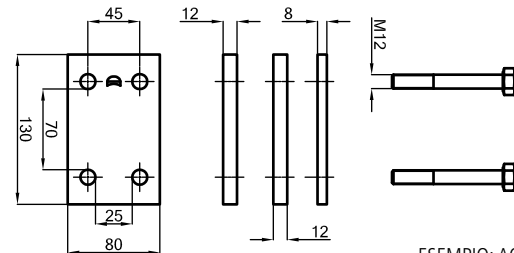

ESEMPIO: AQ25T

AQ25T	tub. 70x70	n. 1 80x8 n. 2 80x12	n. 4 12x140	2,80
AQ25T1	tub. 80x80	n. 1 80x8 n. 2 80x12	n. 4 12x150	2,80
AQ25T2	tub. 100x100	n. 1 80x8 n. 2 80x12	n. 4 14x180	3,10

**STAFFA D'ATTACCO COMPLETA
 PER QUADRA 30x30**

Complete support for square-spring 30x30
 Stütze für vierkantige Zinke 30x30
 Bride complet pour ressort carré 30x30
 Стремя в комплекте для пружинной стойки 30x30

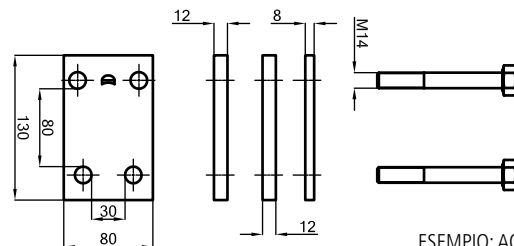

ESEMPIO: AQ30T1

AQ30T1	tub. 80x80	n. 1 80x8 n. 2 80x12	n. 4 14x160	3,24
AQ30T2	tub. 100x100	n. 1 80x8 n. 2 80x12	n. 4 14x180	3,68
AQ35T1	tub. 100x100	n. 1 100x8 n. 2 100x15	n. 4 16x200	6,00

A stylized globe with a grid of latitude and longitude lines. A banner is draped across the middle of the globe, containing the word "eurozappa" in a bold, lowercase, sans-serif font.

eurozappa

SOCS REVERSIBILI E VOMERI A LANCIA

Reversible socs

Umgekehrte Socs und Breitschare

Socs reversibles

Культиваторные лапы





SOCS REVERSIBILI E VOMERI A LANCIA

Reversible socs

Umgekehrte Socs und Breiteschare

Socs reversibles

Культиваторные лапы

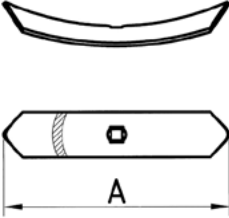
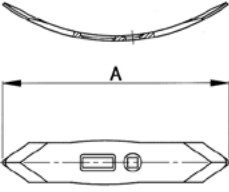
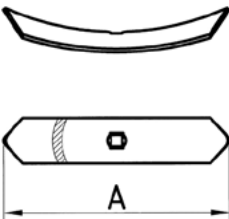
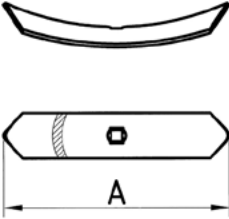
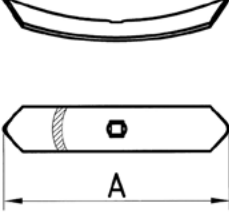
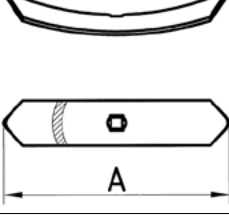
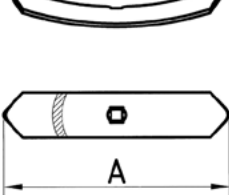

Descrizione Description Beschreibung Description Описание	Codice Nr. Ref. Nr. Re. Nr. Ref. Nr. Код №		Quote Dimensions Abmessungen Dimensions Размеры mm	Piatto Plate Platte Plaque Профиль mm	Fori Holes Löcher Trous Отверстия Ø mm	Interasse Center distance Achsenabstand Entraxe Расстояние Ø - Ø	Peso Weight Gewicht Poids Вес gr
Soc reversibile	550001		A = 190	40x5	10,5	—	270
Soc piatto punte forgiate	550016		A = 230	45x7	11,5	45-50	480
Soc reversibile Tipo Rau	550030		A = 177	40x5	10,5	—	260
Soc reversibile	550031		A = 190	40x6	10,5	—	310
Soc reversibile Konskild	550032		A = 150	25x5	8,5	—	130
Soc reversibile	550034		A = 210	40x6	10,5	—	350
Soc reversibile America	550060		A = 255	50x6	10,5	—	560

Tutti i modelli sono di nostra produzione e non originali.
All models are of our manufacture and are not original.
Alle unsere Landwirtschaftliche erzeugnisse sind unsere produktion und sind nicht original.
Tous les modèles sont notre production et ne sont pas des produits d'origine.
Все модели нашего производства и не являются оригинальными.

N.B. Pesi e misure sopra descritti sono puramente indicativi.
N.B. The above weights and dimensions are given for reference only.
N.B. Die obengenannten Gewichte und Abmessungen sind richtungsweisend.
N.B. Les poids et les dimensions indiqués ci-dessus sont donnés à titre indicatif.
N.B. Указанные вес и размеры, являются ориентировочными.

© La riproduzione
anche parziale
del presente catalogo
è vietata.

SOCS REVERSIBILI E VOMERI A LANCIA

Reversible socs

Umgekehrte Socs und Breiteschare

Socs reversibles

Культиваторные лапы

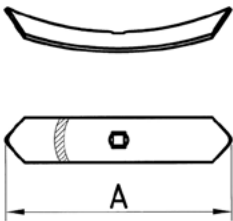
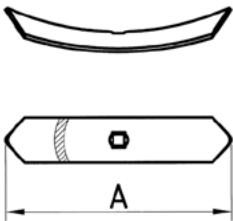
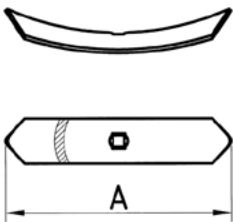
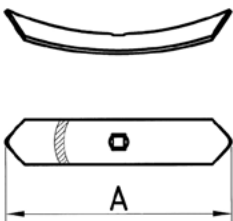
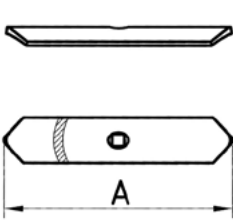
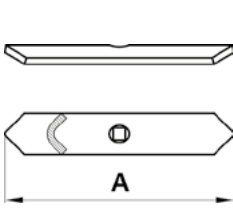
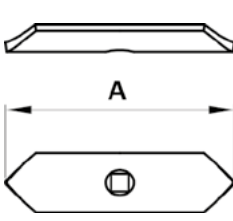
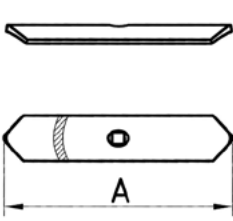

Descrizione Description Beschreibung Description Описание	Codice Nr. Ref. Nr. Re. Nr. Ref. Nr. Код №		Quote Dimensions Abmessungen Dimensions Размеры mm	Piatto Plate Platte Plaque Профиль mm	Fori Holes Löcher Trous Отверстия Ø mm	Interasse Center distance Achsenabstand Entraxe Расстояние Ø - Ø	Peso Weight Gewicht Poids Вес gr
Soc reversibile per molla 45x12	550067		A = 255	60x6	10,5	—	660
Soc reversibile America	550067A		A = 255	60x6	12,5	—	660
Soc reversibile	550102		A = 210	40x8	10,5	—	540
Vomere reversibile dritto per molla 32x12	550122		A = 195	40x5	10,5	—	280
Soc dritto	550134		A = 195	40x6	10,5	—	330
Soc dritto	550135		A = 135	40x5	10,5	—	200
Soc dritto	550136		A = 135	40x6	10,5	—	210

SOCS REVERSIBILI E VOMERI A LANCIA

Reversible socs

Umgekehrte Socs und Breiteschare

Socs reversibles

Культиваторные лапы

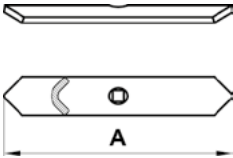
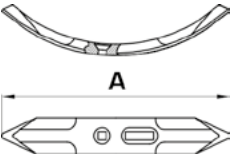
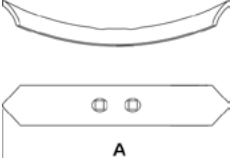
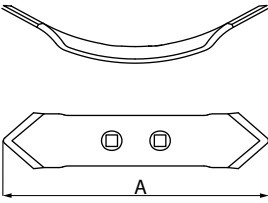
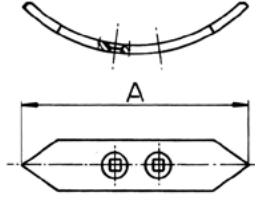
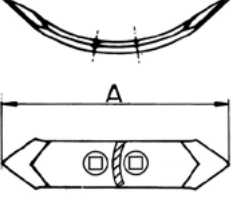
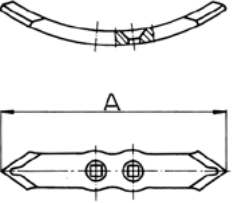

Descrizione Description Beschreibung Description Описание	Codice Nr. Ref. Nr. Re. Nr. Ref. Nr. Код №		Quote Dimensions Abmessungen Dimensions Размеры mm	Piatto Plate Platte Plaque Профиль mm	Fori Holes Löcher Trous Отверстия Ø mm	Interasse Center distance Achsenabstand Entraxe Расстояние Ø - Ø	Peso Weight Gewicht Poids Вес gr
Soc diritto	550185		A = 210	40x6	10,5	—	360
Soc stampato HC119	550226		A = 365	55x15	13-13x45	44-76	2150
Soc per molla Kockerling	550299		A = 305	53x8	11,5	45	900
Soc reversibile 2 fori	550338		A = 248	50x8	10,7	45	500
Punzenat	800002		A = 230	50x8	12,5	45	790
Soc ½ tondo punte forgiate M.F.	800003		A = 265	65x8	12	45	1050
Soc piatto punte stampate	800005		A = 270	40x16	14	35	1130

Tutti i modelli sono di nostra produzione e non originali.
All models are of our manufacture and are not original.
Alle unsere Landwirtschaftliche erzeugnisse sind unsere produktion und sind nicht original.
Tous les modèles sont notre production et ne sont pas des produits d'origine.
Все модели нашего производства и не являются оригинальными.

N.B. Pesi e misure sopra descritti sono puramente indicativi.
N.B. The above weights and dimensions are given for reference only.
N.B. Die obengenannten Gewichte und Abmessungen sind richtungsweisend.
N.B. Les poids et les dimensions indiqués ci-dessus sont donnés à titre indicatif.
N.B. Указанные вес и размеры, являются ориентировочными.

© La riproduzione anche parziale del presente catalogo è vietata.

SOCS REVERSIBILI E VOMERI A LANCIA

Reversible socs

Umgekehrte Socs und Breiteschare

Socs reversibles

Культиваторные лапы

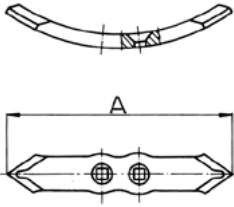
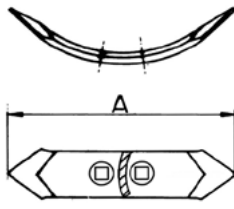
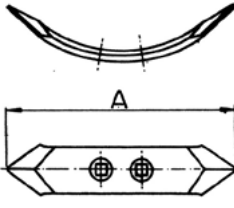
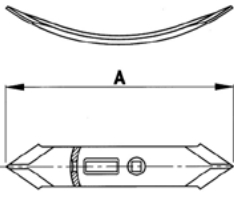
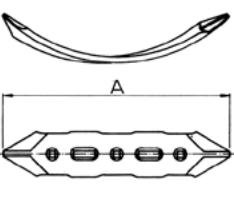
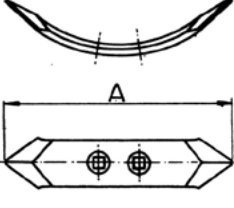
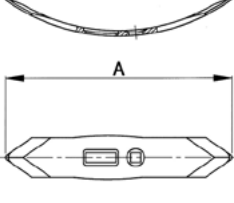

Descrizione Description Beschreibung Description Описание	Codice Nr. Ref. Nr. Re. Nr. Ref. Nr. Код №		Quote Dimensions Abmessungen Dimensions Размеры mm	Piatto Plate Platte Plaque Профиль mm	Fori Holes Löcher Trous Отверстия Ø mm	Interasse Center distance Achsenabstand Entraxe Расстояние Ø - Ø	Peso Weight Gewicht Poids Вес gr
Soc piatto punte stampate	800006		A = 270	40x16	14	45	1130
Soc ½ tondo punte forgiate M.F.	800007		A = 250	50x8	12	45	750
Soc piatto punte stampate L.S. 5515	800009		A = 400	55x15	14	60	2470
Soc foro + asola	800010		A = 400	55x15	14	44-65	2470
Vomere Twist 3 fori + 2 asole	800013		A = 485	75x10	45x13	45-75	2660
Soc Chisel punte forgiate	800019		A = 360	55x15	14,5	60	2100
Soc foro ad asola piatto	800020		A = 265	45x6	10,5	25-50	500

SOCS REVERSIBILI E VOMERI A LANCIA

Reversible socs

Umgekehrte Socs und Breiteschare

Socs reversibles

Культиваторные лапы

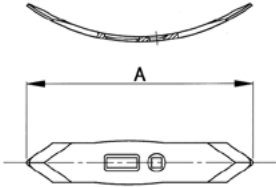
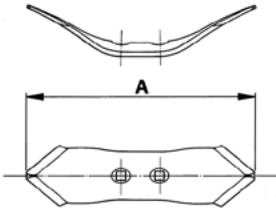
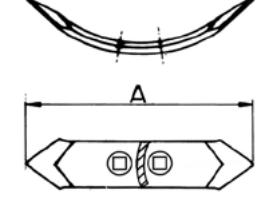
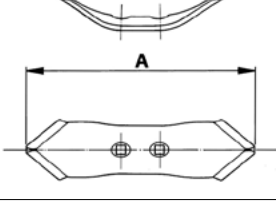
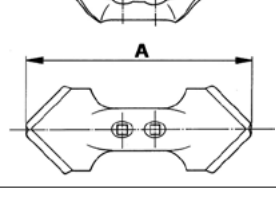
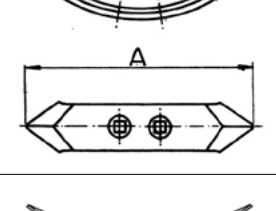
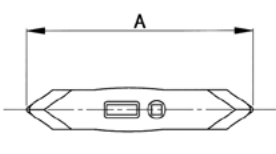

Descrizione Description Beschreibung Description Описание	Codice Nr. Ref. Nr. Re. Nr. Ref. Nr. Код №		Quote Dimensions Abmessungen Dimensions Размеры mm	Piatto Plate Platte Plaque Профиль mm	Fori Holes Löcher Trous Отверстия Ø mm	Interasse Center distance Achsenabstand Entraxe Расстояние Ø - Ø	Peso Weight Gewicht Poids Вес gr
Soc foro e asola 6021-796 ½ tondo	800024		A = 245	50x6	11,5	40-56	560
Soc America ½ tondo	800025		A = 260	65x6	12,5	44	730
Soc M.F. ½ tondo	800026		A = 250	65x8	13	45	900
Soc Vibroflex ½ tondo	800030		A = 295	65x8	12	45	1150
Soc Vibroflex ½ tondo	800031		A = 295	110x6	12,5	43	1160
Soc 14006 piatto	800033		A = 350	40x12	12,5	56-60	1500
Soc 14008 piatto	800035		A = 330	65x10	12,5	56-60	1710

Tutti i modelli sono di nostra produzione e non originali.
All models are of our manufacture and are not original.
Alle unsere Landwirtschaftliche erzeugnisse sind unsere produktion und sind nicht original.
Tous les modèles sont notre production et ne sont pas des produits d'origine.
Все модели нашего производства и не являются оригинальными.

N.B. Pesi e misure sopra descritti sono puramente indicativi.
N.B. The above weights and dimensions are given for reference only.
N.B. Die obengenannten Gewichte und Abmessungen sind richtungsweisend.
N.B. Les poids et les dimensions indiqués ci-dessus sont donnés à titre indicatif.
N.B. Указанные вес и размеры, являются ориентировочными.

© La riproduzione
anche parziale
del presente catalogo
è vietata.

SOCS REVERSIBILI E VOMERI A LANCIA

Reversible socs

Umgekehrte Socs und Breiteschare

Socs reversibles

Культиваторные лапы



Descrizione Description Beschreibung Description Описание	Codice Nr. Ref. Nr. Re. Nr. Ref. Nr. Код №		Quote Dimensions Abmessungen Dimensions Размеры mm	Piatto Plate Platte Plaque Профиль mm	Fori Holes Löcher Trous Отверстия Ø mm	Interasse Center distance Achsenabstand Entraxe Расстояние Ø - Ø	Peso Weight Gewicht Poids Вес gr
Soc 14009 piatto	800036		A = 330	75×12	12,5	56-60	2390
Soc 14011 ½ tondo Bonford Super Flow	800037		A = 392	75×10	11,5	85	2270
Soc 14034A piatto Bonford Low Flow	800038		A = 380	80×12	11,5	54-60	2850
Soc 14017 Vibroflex ½ tondo	800041		A = 300	110×8	12,5	45	2070
Soc piatto punte stampate	800042		A = 285	60×12	12,5×17,5	45-50	1400
Soc piatto Chisel	800043		A = 300	55×15	12,5	45	1780
Soc piatto punte stampate	800046		A = 235	40×16	12	54.62	1050

230

Tutti i modelli sono di nostra produzione e non originali.
All models are of our manufacture and are not original.
Alle unsere Landwirtschaftliche erzeugnisse sind unsere produktion und sind nicht original.
Tous les modèles sont notre production et ne sont pas des produits d'origine.
Все модели нашего производства и не являются оригинальными.

N.B. Pesi e misure sopra descritti sono puramente indicativi.
N.B. The above weights and dimensions are given for reference only.
N.B. Die obengenannten Gewichte und Abmessungen sind richtungsweisend.
N.B. Les poids et les dimensions indiqués ci-dessus sont donnés à titre indicatif.
N.B. Указанные вес и размеры, являются ориентировочными.

© La riproduzione
anche parziale
del presente catalogo
è vietata.

SOCS REVERSIBILI E VOMERI A LANCIA

Reversible socs

Umgekehrte Socs und Breiteschare

Socs reversibles

Культиваторные лапы



Descrizione Description Beschreibung Description Описание	Codice Nr. Ref. Nr. Re. Nr. Ref. Nr. Код №		Quote Dimensions Abmessungen Dimensions Размеры mm	Piatto Plate Platte Plaque Профиль mm	Fori Holes Löcher Trous Отверстия Ø mm	Interasse Center distance Achsenabstand Entraxe Расстояние Ø - Ø	Peso Weight Gewicht Poids Вес gr
Soc 2 punte foro + asola	800048		A = 292	60x10	13	45-52	1220
Soc 2 punte 2 fori	800049		A = 300	40x16	14,5	45	1130
Soc 2 punte 2 fori + 1 asola	800050		A = 400	55x15	13	45-75	2440
Soc 2 punte ½ tondo	800051		A = 250	65x8	13	35-60	890
Soc 2 punte 2 fori	800052		A = 330	65x8	13	45	1220
Soc 2 punte 2 asole	800053		A = 365	60x12	13x33	43-82	1850
Soc doppio cuore Tipo tedesco stampato - forged type foro + asola Universale	800058		A = 440	—	13,5	44-75	3400

Tutti i modelli sono di nostra produzione e non originali.
All models are of our manufacture and are not original.
Alle unsere Landwirtschaftliche erzeugnisse sind unsere produktion und sind nicht original.
Tous les modèles sont notre production et ne sont pas des produits d'origine.
Все модели нашего производства и не являются оригинальными.

N.B. Pesi e misure sopra descritti sono puramente indicativi.
N.B. The above weights and dimensions are given for reference only.
N.B. Die obengenannten Gewichte und Abmessungen sind richtungsweisend.
N.B. Les poids et les dimensions indiqués ci-dessus sont donnés à titre indicatif.
N.B. Указанные вес и размеры, являются ориентировочными.

© La riproduzione
anche parziale
del presente catalogo
è vietata.

SOCS REVERSIBILI E VOMERI A LANCIA

Reversible socs

Umgekehrte Socs und Breiteschare

Socs reversibles

Культиваторные лапы

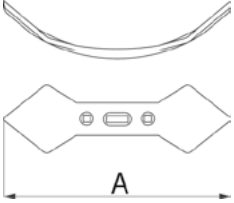
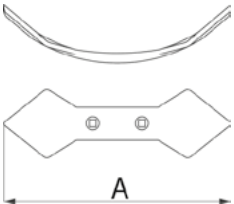
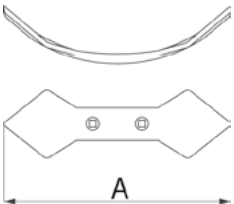
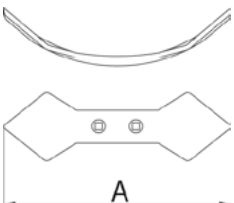
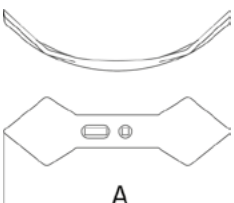
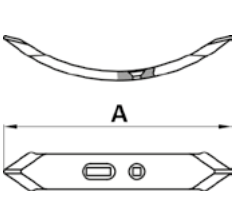
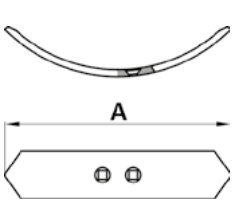

Descrizione Description Beschreibung Description Описание	Codice Nr. Ref. Nr. Re. Nr. Ref. Nr. Код №		Quote Dimensions Abmessungen Dimensions Размеры mm	Piatto Plate Platte Plaque Профиль mm	Fori Holes Löcher Trous Отверстия Ø mm	Interasse Center distance Achsenabstand Entraxe Расстояние Ø - Ø	Peso Weight Gewicht Poids Вес gr
Soc doppio cuore Tipo tedesco stampato - forged type 2 fori + 1 asola Universale	800059		A = 440	—	13,5	44-75	3400
Soc doppio cuore Tipo tedesco stampato - forged type 2 fori Rabewerk	800060		A = 440	—	13,5	45	3400
Soc doppio cuore Tipo tedesco stampato - forged type 2 fori Rau	800061		A = 440	—	13,5	70	3400
Soc doppio cuore stampato 2 fori	800064		A = 450	—	15	70	3400
Soc doppio cuore stampato foro e asola	800065		A = 450	—	45x15	44-75	3400
Soc chisel foro e asola	800068		A = 360	55x15	14,5	45-60	2225
Soc reversibile 2 fori	800070		A = 330	70x10	13,5	45	1950

SOCS REVERSIBILI E VOMERI A LANCIA

Reversible socs

Umgekehrte Socs und Breiteschare

Socs reversibles

Культиваторные лапы



Descrizione Description Beschreibung Description Описание	Codice Nr. Ref. Nr. Re. Nr. Ref. Nr. Код №		Quote Dimensions Abmessungen Dimensions Размеры mm	Piatto Plate Platte Plaque Профиль mm	Fori Holes Löcher Trous Отверстия Ø mm	Interasse Center distance Achsenabstand Entraxe Расстояние Ø - Ø	Peso Weight Gewicht Poids Вес gr
Soc reversibile foro + asola	800071		A = 285	55x15	17x12,5	45-50	1650
Soc chisel 2 asole	800072		A = 400	55x15	34x13	44-82	2500
Soc a 2 punte 2 fori quadri	800077		A = 260	50x8	12,5	45	730
Soc a 2 punte 1 foro + 1 asola	800081		A = 260	50x6	37,5x13,5	35-59	540
Soc a 2 punte 1 foro + 1 asola	800082		A = 260	65x8	37,5x13,5	35-59	880
Vomere Twist 3 fori + 2 asole	800085		A = 510	75x10	45x13	45-75- 120	2840
Soc Lemken 3375420	800086		A = 453	60x15	13,5	45	3300

Tutti i modelli sono di nostra produzione e non originali.
All models are of our manufacture and are not original.
Alle unsere Landwirtschaftliche erzeugnisse sind unsere produktion und sind nicht original.
Tous les modèles sont notre production et ne sont pas des produits d'origine.
Все модели нашего производства и не являются оригинальными.

N.B. Pesi e misure sopra descritti sono puramente indicativi.
N.B. The above weights and dimensions are given for reference only.
N.B. Die obengenannten Gewichte und Abmessungen sind richtungsweisend.
N.B. Les poids et les dimensions indiqués ci-dessus sont donnés à titre indicatif.
N.B. Указанные вес и размеры, являются ориентировочными.

© La riproduzione
anche parziale
del presente catalogo
è vietata.

SOCS REVERSIBILI E VOMERI A LANCIA

Reversible socs

Umgekehrte Socs und Breiteschare

Socs reversibles

Культиваторные лапы



Descrizione Description Beschreibung Description Описание	Codice Nr. Ref. Nr. Re. Nr. Ref. Nr. Код №		Quote Dimensions Abmessungen Dimensions Размеры mm	Piatto Plate Platte Plaque Профиль mm	Fori Holes Löcher Trous Отверстия Ø mm	Interasse Center distance Achsenabstand Entraxe Расстояние Ø - Ø	Peso Weight Gewicht Poids Вес gr
Soc Kockerling 506008	800087		A = 470	65x15	45x13	45-75	3310
Soc Konskilde point	800088		A = 310	80x8	12,5	40	1400
Soc doppio cuore stampato 2 fori + asola	800090		A = 450	—	14x28	56-70	3400
Soc twist 3 fori + 2 asole HC121 / HC122	800097		A = 485	75x12,5	13,5x45	45-75	3300
Vomere dritto 2 fori + 1 asola	800101		A = 410	60x20	17,2	55-65	3700
Vomere a tre fori quadri	800103		A = 413	80x15	13,5	66-66	3300
Soc a 2 punte 1 foro + 1 asola	800133		A = 300	55x15	13	45-75	1950

SOCS REVERSIBILI E VOMERI A LANCIA

Reversible socs

Umgekehrte Socs und Breiteschare

Socs reversibles

Культиваторные лапы



Descrizione Description Beschreibung Description Описание	Codice Nr. Ref. Nr. Re. Nr. Ref. Nr. Код №		Quote Dimensions Abmessungen Dimensions Размеры mm	Piatto Plate Platte Plaque Профиль mm	Fori Holes Löcher Trous Отверстия Ø mm	Interasse Center distance Achsenabstand Entraxe Расстояние Ø - Ø	Peso Weight Gewicht Poids Вес gr
Soc a 2 punte 2 asole	800134		A = 365	60x20	13	43-82	3080
Soc a 1 punta per seminatrice	800152		A = 170	45x7	11	45	440
Vomere a lancia	550017		A = 175	175x4	10,5	—	450
Vomere a zampa d'oca	550018		A = 70 B = 140	70x4	10,5	—	230
Vomere a lancia	550027		A = 105	105x4	10,5	—	230
Vomere a lancia	550028		A = 150	150x4	10,5	—	400
Vomere a lancia Danish	550055		A = 105	105x6	10,2	—	330

Tutti i modelli sono di nostra produzione e non originali.
All models are of our manufacture and are not original.
Alle unsere Landwirtschaftliche erzeuignisse sind unsere produktion und sind nicht original.
Tous les modèles sont notre production et ne sont pas des produits d'origine.
Все модели нашего производства и не являются оригинальными.

N.B. Pesi e misure sopra descritti sono puramente indicativi.
N.B. The above weights and dimensions are given for reference only.
N.B. Die obengenannten Gewichte und Abmessungen sind richtungsweisend.
N.B. Les poids et les dimensions indiqués ci-dessus sont donnés à titre indicatif.
N.B. Указанные вес и размеры, являются ориентировочными.

© La riproduzione
anche parziale
del presente catalogo
è vietata.

SOCS REVERSIBILI E VOMERI A LANCIA

Reversible socs

Umgekehrte Socs und Breiteschare

Socs reversibles

Культиваторные лапы



Descrizione Description Beschreibung Description Описание	Codice Nr. Ref. Nr. Re. Nr. Ref. Nr. Код №		Quote Dimensions Abmessungen Dimensions Размеры mm	Piatto Plate Platte Plaque Профиль mm	Fori Holes Löcher Trous Отверстия Ø mm	Interasse Center distance Achsenabstand Entraxe Расстояние Ø - Ø	Peso Weight Gewicht Poids Вес gr
Vomere a lancia	550055A		A = 105	105x6	12,5	—	330
Vomere a lancia	550055F		A = 105	105x6	10,5	—	330
Vomere a lancia	550055T		A = 105	105x6	12,5	—	330
Vomere zampa d'oca Danish	550057		A = 70 B = 152	70x6	10,5	—	250
Vomere a lancia Gaspardo	550139		A = 150	150x4	10,5	—	470
Vomere a lancia	550151		A = 200	200x4	10,5	—	430
Vomere a lancia	550152		A = 250	250x4	10,5	—	640

SOCS REVERSIBILI E VOMERI A LANCIA

Reversible socs

Umgekehrte Socs und Breiteschare

Socs reversibles

Культиваторные лапы



Descrizione Description Beschreibung Description Описание	Codice Nr. Ref. Nr. Re. Nr. Ref. Nr. Код №		Quote Dimensions Abmessungen Dimensions Размеры mm	Piatto Plate Platte Plaque Профиль mm	Fori Holes Löcher Trous Отверстия Ø mm	Interasse Center distance Achsenabstand Entraxe Расстояние Ø - Ø	Peso Weight Gewicht Poids Вес gr
Vomere a lancia per molla quadra	550192		A = 210	210x6	13	45-50	1080
Vomere a lancia per molla quadra	550193		A = 240	240x6	13	45-50	1200
Vomere a lancia	550195		A = 180	180x5	10,5	—	530
Vomere a lancia Canada	550240		A = 255	255x6	13,5	56	2100
Vomere a lancia Canada	550241		A = 240	240x6	12,5	45	1200
Vomere a lancia stampato HC120	550275		A = 180	—	13,5	45-75	2700
Vomere a lancia stampato BH701 78801569	550276		A = 310	—	13,5	45-75	3800

Tutti i modelli sono di nostra produzione e non originali.
All models are of our manufacture and are not original.
Alle unsere Landwirtschaftliche erzeugnisse sind unsere produktion und sind nicht original.
Tous les modèles sont notre production et ne sont pas des produits d'origine.
Все модели нашего производства и не являются оригинальными.

N.B. Pesi e misure sopra descritti sono puramente indicativi.
N.B. The above weights and dimensions are given for reference only.
N.B. Die obengenannten Gewichte und Abmessungen sind richtungsweisend.
N.B. Les poids et les dimensions indiqués ci-dessus sont donnés à titre indicatif.
N.B. Указанные вес и размеры, являются ориентировочными.

© La riproduzione
anche parziale
del presente catalogo
è vietata.

SOCS REVERSIBILI E VOMERI A LANCIA

Reversible socs

Umgekehrte Socs und Breiteschare

Socs reversibles

Культиваторные лапы



Descrizione Description Beschreibung Description Описание	Codice Nr. Ref. Nr. Re. Nr. Ref. Nr. Код №		Quote Dimensions Abmessungen Dimensions Размеры mm	Piatto Plate Platte Plaque Профиль mm	Fori Holes Löcher Trous Отверстия Ø mm	Interasse Center distance Achsenabstand Entraxe Расстояние Ø - Ø	Peso Weight Gewicht Poids Вес gr
Vomere a lancia Kockerling 504027	550278		A = 180	180x5	11,5	45	840
Vomere a lancia per molla Kockerling	550300		A = 200	200x5	11,5	45	880
Vomere a lancia per molla Kockerling	550301		A = 180	180x5	11,5	45	880
Vomere a lancia	550311		A = 190	190x6	10,5	45	880
Vomere a lancia	550340		A = 330	330x6	12,5	45	1470
Vomere a lancia	550342		A = 230	230x6	12,5	45	1300
Vomere a lancia	550346		A = 260	260x6	12,5	45	1380





eurozappa

COMPONENTI E SISTEMI PER COLTIVATORI
Components and systems for cultivators
Komponenten und Systeme für Grubber
Composants et systèmes pour cultivateurs
Системы и компоненты для культиваторов



eurozappa



E

COMPONENTI E SISTEMI PER COLTIVATORI
Components and systems for cultivators
Komponenten und Systeme für Grubber
Composants et systèmes pour cultivateurs
Системы и компоненты для культиваторов



Descrizione Description Beschreibung Description Описание		Quote Dimensions Abmessungen Dimensions Размеры mm	Codice Eurozappa Eurozappa Ref. Nr. Eurozappa Ref. Nr. Eurozappa Ref. Nr. Код Еврозаппа №	Piatto Plate Platte Plaque Профиль mm	Fori Holes Löcher Trous Отверстия mm	Interasse Center distance Achsenabstand Entraxe Расстояние Ø - Ø	Peso Weight Gewicht Poids Вес gr
---	--	---	---	--	---	---	---

VOMERI E COMPONENTI PER COLTIVATORI	CULTIVATOR SHARES AND PARTS FOR CULTIVATORS PFLUGSCHAREN UND KOMPONENTEN FÜR KULTIVATORS SOCS ET COMPOSANTS POUR CULTIVATEURS						
ADATTATORE INT. 45		A = 160	ADATTATORE/ 45		12,5	45	850
ADATTATORE INT. 70		A = 140	ADATTATORE/ 70		12,5	70	850
KIT PER ANCORA ATTACCO RAPIDO			KIT-R01				50
KIT PER MOLLE QUADRE E CHISEL ATTACCO RAPIDO			KIT-R02				50
KIT PER ADATTATORE INT.45			KIT-A01				52
KIT PER ADATTATORE INT.70			KIT-A02				52

Tutti i modelli sono di nostra produzione e non originali.
 All models are of our manufacture and are not original.
 Alle unsere Landwirtschaftliche erzeugnisse sind unsere produktion und sind nicht original.
 Tous les modèles sont notre production et ne sont pas des produits d'origine.
 Все модели нашего производства и не являются оригинальными.

N.B. Pesi e misure sopra descritti sono puramente indicativi.
 N.B. The above weights and dimensions are given for reference only.
 N.B. Die obengenannten Gewichte und Abmessungen sind richtungsweisend.
 N.B. Les poids et les dimensions indiqués ci-dessus sont donnés à titre indicatif.
 N.B. Указанные вес и размеры, являются ориентировочными.

© La riproduzione anche parziale del presente catalogo è vietata.

COMPONENTI E SISTEMI PER COLTIVATORI
Components and systems for cultivators
Komponenten und Systeme für Grubber
Composants et systèmes pour cultivateurs
Системы и компоненты для культиваторов

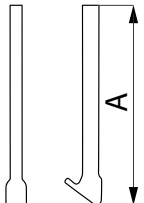
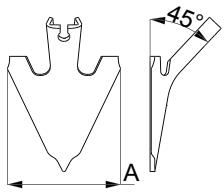
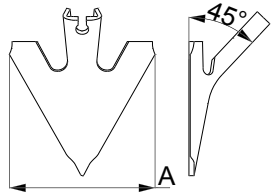
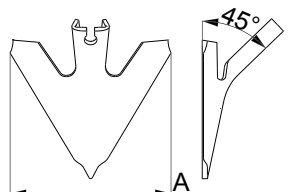
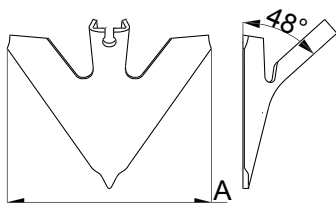
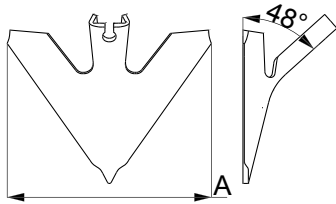

Descrizione Description Beschreibung Description Описание		Quote Dimensions Abmessungen Dimensions Размеры mm	Codice Eurozappa Eurozappa Ref. Nr. Eurozappa Ref. Nr. Eurozappa Ref. Nr. Код Еврозатпа №	Piatto Plate Platte Plaque Профиль mm	Fori Holes Löcher Trous Отверстия mm	Interasse Center distance Achsenabstand Entraxe Расстояние Ø - Ø	Peso Weight Gewicht Poids Вес gr
LEVA PER SGANCIO RAPIDO		A = 270	LEVA-KIT				310
VOMERE CON ATTACCO RAPIDO		A = 180	AR.VO180X8				1575
VOMERE CON ATTACCO RAPIDO		A = 220	AR.VO220X8				1790
VOMERE CON ATTACCO RAPIDO		A = 250	AR.VO250X8				2000
VOMERE CON ATTACCO RAPIDO		A = 300	AR.VO300X8				2320
VOMERE CON ATTACCO RAPIDO		A = 330	AR.VO330X8				2600



eurozappa



COMPONENTI E SISTEMI PER COLTIVATORI
Components and systems for cultivators
Komponenten und Systeme für Grubber
Composants et systèmes pour cultivateurs
Системы и компоненты для культиваторов

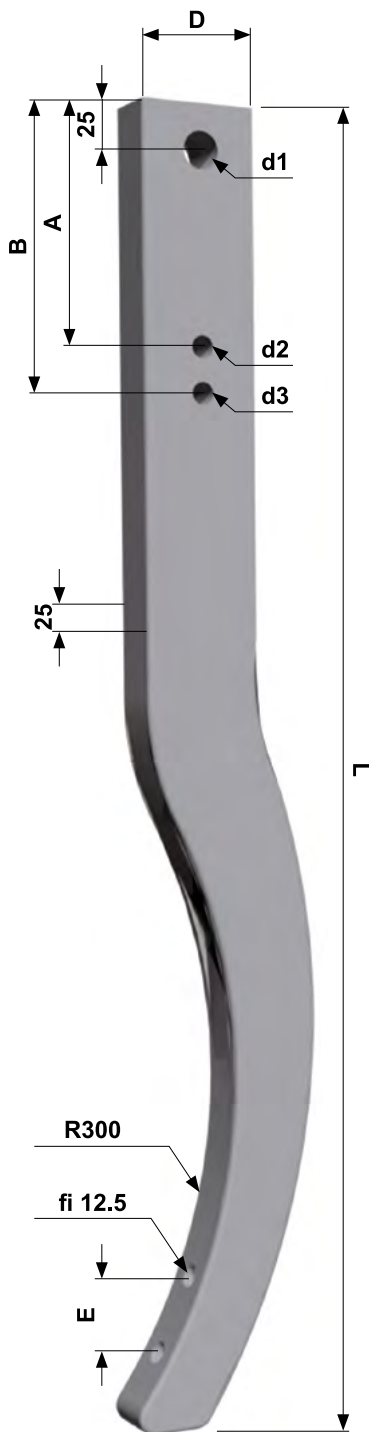

Codice Nr. Ref. Nr. Re. Nr. Ref. Nr. Код №	L	d1	d2	d3	A	B	D	E	Peso Weight Gewicht Poids Вес gr
AN101.6067LL	680	12,5	21	—	140	—	60	70	7700
AN101.6072LL	720	17	—	—	—	—	60	70	8300
AN101.6072LL-1	720	17	—	—	—	—	60	45	8300
AN101.6072LL-2	720	21	—	—	—	—	60	45	8300
AN101.6072LL-3	720	17	13	—	130	—	60	45	8300
AN101.6072LL-5	720	21	14,5	—	175	—	60	45	8300
AN101.6072LL-7	720	21	14	—	80	—	60	45	8300
AN101.6072LL-8	720	21	—	—	—	—	60	70	8300
AN101.6072LL-9	720	21	13	—	92,5	—	60	45	8300
AN101.6072LL-12	720	21	12,5	—	150	—	60	70	8300
AN101.6072LL-13	720	17	12,5	—	110	—	60	70	8300
AN101.6073LL	740	20,5	12,5	—	150	—	60	45	8500
AN101.6075LL	750	20,5	12,5	12,5	125	155	60	45	8700
AN101.6075LL-1	750	17	13	—	131	—	60	45	8700
AN101.6075LL-4	750	20,5	12,5	—	150	—	60	70	8700
AN101.6082LL	820	17	—	—	—	—	60	70	9360
AN101.6082LL-1	820	20,5	16,5	16,5	135	170	60	70	9360
AN101.6082LL-3	820	21	14,5	—	175	—	60	70	9360
AN101.6083LL	835	21	12,5	—	150	—	60	45	9500

Tutti i modelli sono di nostra produzione e non originali.
 All models are of our manufacture and are not original.
 Alle unsere Landwirtschaftliche erzeugnisse sind unsere produktion und sind nicht original.
 Tous les modèles sont notre production et ne sont pas des produits d'origine.
 Все модели нашего производства и не являются оригинальными.







N.B. Pesi e misure sopra descritti sono puramente indicativi.
 N.B. The above weights and dimensions are given for reference only.
 N.B. Die obengenannten Gewichte und Abmessungen sind richtungsweisend.
 N.B. Les poids et les dimensions indiqués ci-dessus sont donnés à titre indicatif.
 N.B. Указанные вес и размеры, являются ориентировочными.

© La riproduzione
 anche parziale
 del presente catalogo
 è vietata.

COMPONENTI E SISTEMI PER COLTIVATORI
Components and systems for cultivators
Komponenten und Systeme für Grubber
Composants et systèmes pour cultivateurs
Системы и компоненты для культиваторов



Descrizione Description Beschreibung Description Описание	Codice Eurozappa Eurozappa Ref. Nr. Eurozappa Re. Nr. Eurozappa Ref. Nr. Код Еврозаппа №	Codice originale Original code Original kode Code d'origine Оригинальный код	DX / SX R / L R / L D / G П / Л	Spessore Thickness Stärke Épaisseur mm	Peso Weight Gewicht Poids Вес gr
---	--	--	---	--	---

VOMERI E COMPONENTI PER COLTIVATORI	Cultivator shares and parts for cultivators Pflügschare und Komponenten für Kultivators Socs et composants pour cultivateurs Культиваторные лапы и компоненты для культиваторов				
LEMKEN VOMERE		800054	3374388		10 1700
LEMKEN VOMERE		800113	3374392		12 2100
LEMKEN VOMERE HARD FACED		800113RIP	3374392		12 2230
LEMKEN VOMERE		800114	3374386		15 1900
LEMKEN VERSOIO		800079	3374395		8 1900
LEMKEN VERSOIO		800118DX	3374398	DX	8 2400
		800118SX	3374399	SX	

COMPONENTI E SISTEMI PER COLTIVATORI
Components and systems for cultivators
Komponenten und Systeme für Grubber
Composants et systèmes pour cultivateurs
Системы и компоненты для культиваторов



Descrizione Description Beschreibung Description Описание		Codice Eurozappa Eurozappa Ref. Nr. Eurozappa Re. Nr. Eurozappa Ref. Nr. Код Еврозаппа №	Codice originale Original code Original kode Code d'origine Оригинальный код	DX / SX R / L R / L D / G П / Л	Spessore Thickness Stärke Épaisseur mm	Peso Weight Gewicht Poids Вес gr
UNIVERSAL FOOT		800115	4679105		8	1800
UNIVERSAL FOOT		800116	4679105		10	2300
LEMKEN ALETTA		800056DX	3374418	DX	10	1850
		800056SX	3374419	SX		
LEMKEN ALETTA		800117DX	3374420	DX	10	2200
		800117SX	3374421	SX		
LEMKEN ALETTA HARD FACED		800117DXRIP	3374424	DX	10	2300
		800117SXRIP	3374425	SX		
LEMKEN ALETTA		800055DX	3374416	DX	10	2090
		800055SX	3374417	SX		
VITE E DADO PER ALETTA IN 10.9		656040	3011805			53

Tutti i modelli sono di nostra produzione e non originali.
 All models are of our manufacture and are not original.
 Alle unsere Landwirtschaftliche erzeugnisse sind unsere produktion und sind nicht original.
 Tous les modèles sont notre production et ne sont pas des produits d'origine.
 Все модели нашего производства и не являются оригинальными.

N.B. Pesi e misure sopra descritti sono puramente indicativi.
 N.B. The above weights and dimensions are given for reference only.
 N.B. Die obengenannten Gewichte und Abmessungen sind richtungsweisend.
 N.B. Les poids et les dimensions indiqués ci-dessus sont donnés à titre indicatif.
 N.B. Указанные вес и размеры, являются ориентировочными.

© La riproduzione
 anche parziale
 del presente catalogo
 è vietata.

COMPONENTI E SISTEMI PER COLTIVATORI
Components and systems for cultivators
Komponenten und Systeme für Grubber
Composants et systèmes pour cultivateurs
Системы и компоненты для культиваторов



Descrizione Description Beschreibung Description Описание		Codice Eurozappa Eurozappa Ref. Nr. Eurozappa Re. Nr. Eurozappa Ref. Nr. Код Еврозappa №	Codice originale Original code Original kode Code d'origine Оригинальный код	DX / SX R / L R / L D / G П / Л	Spessore Thickness Stärke Epaisseur mm	Peso Weight Gewicht Poids Вес gr
VITE E DADO PER VERSOIO IN 12.9		656039	3015787			72
VITE E DADO PER FOOT IN 10.9		656037	3015786			64
VITE E DADO PER VOMERE IN 10.9		656038	3015785			52
BEKER, GALUCKO, KONSKILDE, VOMERE		800028			10	1900
QUIVOGNE VOMERE		800044			10	1900
QUIVOGNE VERSOIO		800045			10	2100
KOCKERLING VOMERE		800104	506065		14	2100

COMPONENTI E SISTEMI PER COLTIVATORI
Components and systems for cultivators
Komponenten und Systeme für Grubber
Composants et systèmes pour cultivateurs
Системы и компоненты для культиваторов



Descrizione Description Beschreibung Description Описание		Codice Eurozappa Eurozappa Ref. Nr. Eurozappa Re. Nr. Eurozappa Ref. Nr. Код Еврозаппа №	Codice originale Original code Original kode Code d'origine Оригинальный код	Spessore Thickness Stärke Épaisseur mm	Fori Holes Löcher Trous Отверстия mm	Interasse Center distance Achsenabstand Entraxe Расстояние Ø - Ø	Peso Weight Gewicht Poids Вес gr
HORSCH VOMERE		800120	34060850	12	13		2000
VOMERE DUE ALETTE		750001		12	14,5	65/80	8500
VOMERE DUE ALETTE		750008A		8	12,5	45/75	5600
VOMERE DUE ALETTE		750008		8	12,5	65/80	5600
VOMERE DUE ALETTE		750009		12	12,5	65/80	8500
VOMERE DUE ALETTE		750002		8	14,5	65/80	5600

Tutti i modelli sono di nostra produzione e non originali.
 All models are of our manufacture and are not original.
 Alle unsere Landwirtschaftliche erzeugnisse sind unsere produktion und sind nicht original.
 Tous les modèles sont notre production et ne sont pas des produits d'origine.
 Все модели нашего производства и не являются оригинальными.

N.B. Pesi e misure sopra descritti sono puramente indicativi.
 N.B. The above weights and dimensions are given for reference only.
 N.B. Die obengenannten Gewichte und Abmessungen sind richtungsweisend.
 N.B. Les poids et les dimensions indiqués ci-dessus sont donnés à titre indicatif.
 N.B. Указанные вес и размеры, являются ориентировочными.

© La riproduzione
 anche parziale
 del presente catalogo
 è vietata.

COMPONENTI E SISTEMI PER COLTIVATORI
Components and systems for cultivators
Komponenten und Systeme für Grubber
Composants et systèmes pour cultivateurs
Системы и компоненты для культиваторов

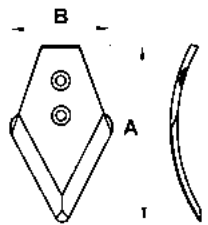
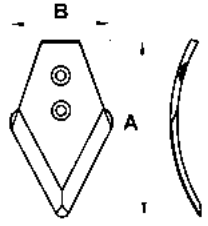
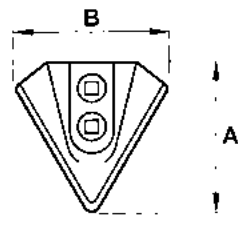
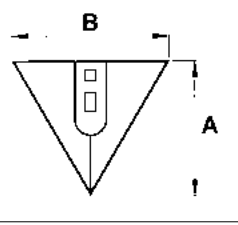
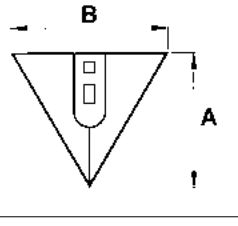
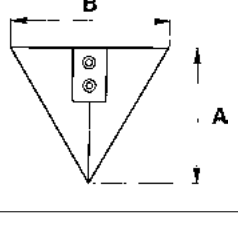
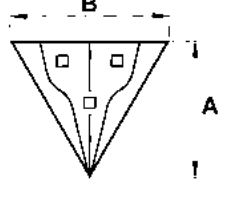

Descrizione Description Beschreibung Description Описание	Quote Dimensions Abmessungen Dimensions Размеры mm	Codice Eurozappa Eurozappa Ref. Nr. Eurozappa Re. Nr. Eurozappa Ref. Nr. Код Еврозатпа №	Spessore Thickness Stärke Epaisseur mm	Fori Holes Löcher Trous Отверстия mm	Interasse Center distance Achsenabstand Entraхе Расстояние Ø - Ø	Peso Weight Gewicht Poids Вес gr	
Toselli		A = 235 B = 112	351001	Spessore 8	12,5	46	1000
Toselli		A = 235 B = 112	351002	Spessore 10	12,5	46	1250
Nardi Tiller 2 C 430		A = 195 B = 195	850002	Spessore 7	13,3	50	1460
Siciltiller		A = 265 B = 250	850004	Spessore 7	13,5x24	44	2750
Siciltiller		A = 245 B = 212	850005	Spessore 7	13,5x24	44	2050
Calà		A = 260 B = 200	850007	Spessore 8	15	67	1970
Siciltiller 3 fori		A = 265 B = 217	850009	Spessore 8	15	56	2260

COMPONENTI E SISTEMI PER COLTIVATORI
Components and systems for cultivators
Komponenten und Systeme für Grubber
Composants et systèmes pour cultivateurs
Системы и компоненты для культиваторов

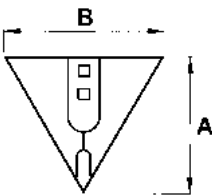
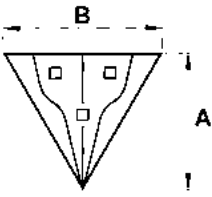
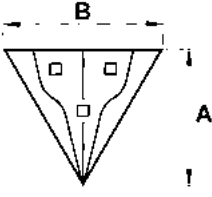

Descrizione Description Beschreibung Description Описание	Quote Dimensions Abmessungen Dimensions Размеры mm	Codice Eurozappa Eurozappa Ref. Nr. Eurozappa Re. Nr. Eurozappa Ref. Nr. Код Еврозатпа №	Spessore Thickness Stärke Epaisseur mm	Fori Holes Löcher Trous Отверстия mm	Interasse Center distance Achsenabstand Entraхе Расстояние Ø - Ø	Peso Weight Gewicht Poids Вес gr	
Cantarella 2 fori		A = 220 B = 200	850014	Spessore 7	13	42	1450
Cantarella 3 fori		A = 220 B = 200	850015	Spessore 7	13	96	1440
Осапа 3 fori		A = 265 B = 234	850017	Spessore 7	13,5	45	2130

Tutti i modelli sono di nostra produzione e non originali.
 All models are of our manufacture and are not original.
 Alle unsere Landwirtschaftliche erzeugnisse sind unsere produktion und sind nicht original.
 Tous les modèles sont notre production et ne sont pas des produits d'origine.
 Все модели нашего производства и не являются оригинальными.

N.B. Pesi e misure sopra descritti sono puramente indicativi.
 N.B. The above weights and dimensions are given for reference only.
 N.B. Die obengenannten Gewichte und Abmessungen sind richtungsweisend.
 N.B. Les poids et les dimensions indiqués ci-dessus sont donnés à titre indicatif.
 N.B. Указанные вес и размеры, являются ориентировочными.

© La riproduzione anche parziale del presente catalogo è vietata.



eurozappa





DISSODATORE 600

SUBSOILER 600



SUBSOILER 600/4



SUBSOILER 600/3

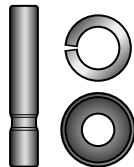

800147KIT



600147B



800147P



800147PC



800112



SUBSOILER 600/2



SUBSOILER 600/1

Descrizione Description Beschreibung Description Описание	Codice Nr. Ref. Nr. Re. Nr. Ref. Nr. Код №	DX / SX R / L R / L D / G П / Л	Quote Dimensions Abmessungen Dimensions Размеры mm	Spessore Thickness Stärke Épaisseur ≠ mm	Interasse Center distance Achsenabstand Entraxe Расстояние ∅ - ∅	Peso Weight Gewicht Poids Вес gr
SUPPORTO	SUBSOILER 600/1 DX	DX	505x158	12		7900
	SUBSOILER 600/1 SX	SX				
CONTROLAMA	SUBSOILER 600/2 DX	DX	195x200	8		2300
	SUBSOILER 600/2 SX	SX				
PUNTA REVERSIBILE	800112		515x50	40	85	4500
BASE ATTACCO RAPIDO	600147B		264x58	40	85	3230
PUNTA ATTACCO RAPIDO	800147P		149x67	58		1850
PUNTA ATTACCO RAPIDO CEMENTATA	800147PC					
VITE E DADO AUTOBLOCCANTE IN 10.9	SUBSOILER 600/4		M14x40			50
SPINA ELASTICA	SUBSOILER 600/3		∅14x50			30
KIT MONTAGGIO ATTACCO RAPIDO	800147KIT		∅11x56			47

Tutti i modelli sono di nostra produzione e non originali.
 All models are of our manufacture and are not original.
 Alle unsere Landwirtschaftliche erzeugnisse sind unsere produktion und sind nicht original.
 Tous les modèles sont notre production et ne sont pas des produits d'origine.
 Все модели нашего производства и не являются оригинальными.

N.B. Pesi e misure sopra descritti sono puramente indicativi.
 N.B. The above weights and dimensions are given for reference only.
 N.B. Die obengenannten Gewichte und Abmessungen sind richtungsweisend.
 N.B. Les poids et les dimensions indiqués ci-dessus sont donnés à titre indicatif.
 N.B. Указанные вес и размеры, являются ориентировочными.

© La riproduzione
 anche parziale
 del presente catalogo
 è vietata.



DISSODATORE 800

SUBSOILER 800



SUBSOILER 800/4



SUBSOILER 800/3

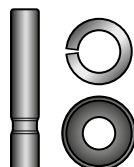

800147KIT



800147B



800147P



800147PC



800109



SUBSOILER 800/2



SUBSOILER 800/6



SUBSOILER 800/1

Descrizione Description Beschreibung Description Описание	Codice Nr. Ref. Nr. Re. Nr. Ref. Nr. Код №	DX / SX R / L R / L D / G П / Л	Quote Dimensions Abmessungen Dimensions Размеры mm	Spessore Thickness Stärke Épaisseur mm	Interasse Center distance Achsenabstand Entraxe Расстояние Ø - Ø	Peso Weight Gewicht Poids Вес gr
SUPPORTO	SUBSOILER 800/1 DX	DX	830x300	15		23300
	SUBSOILER 800/1 SX	SX				
CONTROLAMA	SUBSOILER 800/2 DX	DX	300x240	8		4500
	SUBSOILER 800/2 SX	SX				
CONTROLAMA TIPO LUNGO	SUBSOILER 800/6 DX	DX	455x235	8		7000
	SUBSOILER 800/6 SX	SX				
PUNTA REVERSIBILE	800109		590x61	40	80	7100
BASE ATTACCO RAPIDO	800147B		317x63	40	80	3800
PUNTA ATTACCO RAPIDO	800147P		149x67	58		1850
PUNTA ATTACCO RAPIDO CEMENTATA	800147PC					
VITE E DADO AUTOBLOCCANTE IN 10.9	SUBSOILER 800/4		M14x40			50
SPINA ELASTICA	SUBSOILER 800/3		Ø16x60			45
KIT MONTAGGIO ATTACCO RAPIDO	800147KIT		Ø11x56			47



eurozappa

DISCHI PER ERPICE, PER FRANGIZOLLE E PER SEMINATRICE

Discs for harrows ploughs and seeders

Disques pour herse, brise-mottes et semoirs

Scheiben für Erdschollenbrecher, Sämaschine und Egge

Диски для дисковых борон и сеялок

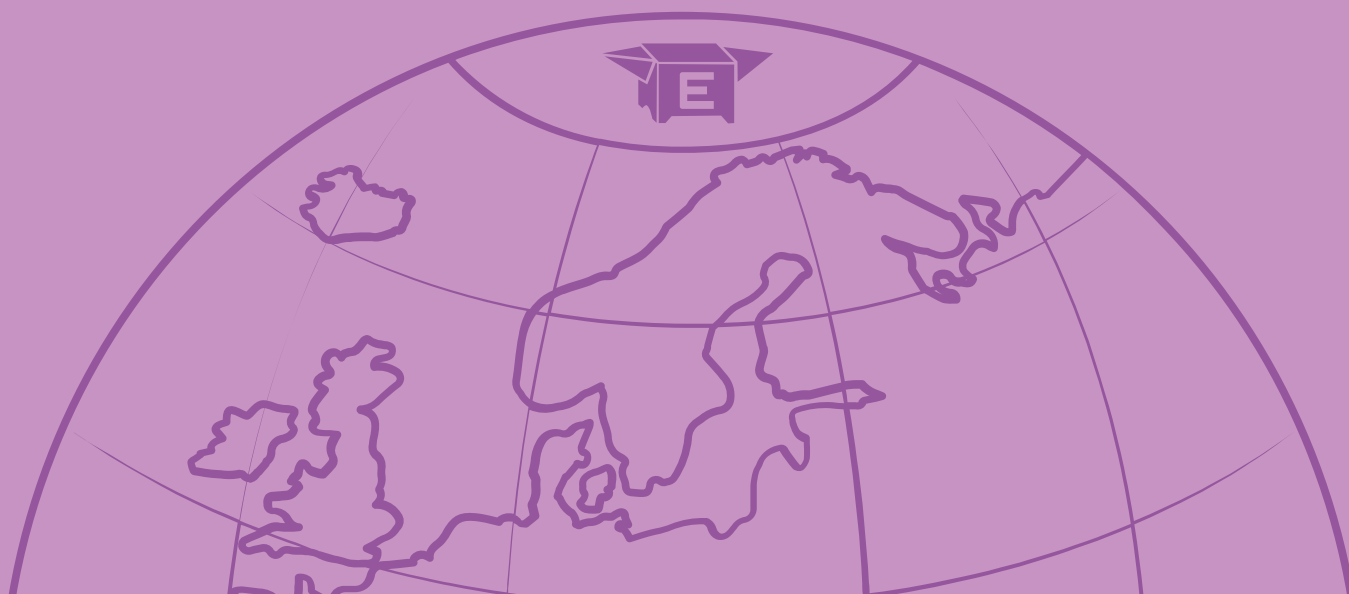

eurozappa



DISCHI PER ERPICE, PER FRANGIZOLLE E PER SEMINATRICE
Discs for harrows ploughs and seeders
Disques pour herses, brise-mottes et semoirs
Scheiben für Eggen, Erdschollenbrecher und Sämaschine
Диски для дисковых борон и сеялок



Marca della macchina Machine brand name Marke der Maschine Marque de la machine Марка машины	Codice Nr. Ref. Nr. Re. Nr. Ref. Nr. Код №	Quote Dimensions Abmessungen Dimensions Размеры mm	Spessore Thickness Stärke Epaisseur Толщина mm	Fori Holes Löcher Trous Отверстие Ø mm	Peso Weight Gewicht Poids Вес gr
--	--	---	---	---	---

**DISCHI PER ERPICE
BOMBATI E DENTATI**

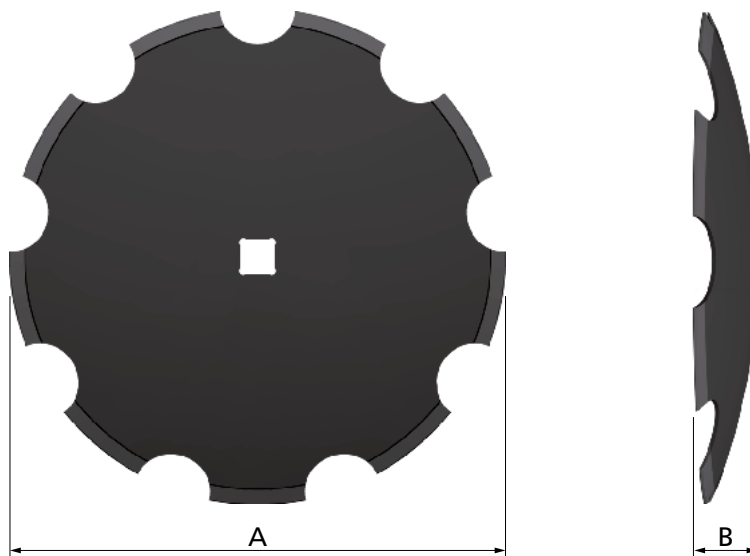

Disco dentato 460 (18")	DISCO 25/D	A = 460 B = 51	3,25	∅ 26	4200
Disco dentato 510 (20")	DISCO 03/D	A = 510 B = 59	4	∅ 26	5900
Disco dentato 510 (20")	DISCO 04/D	A = 510 B = 59	4	∅ 31	5900
Disco dentato 510 (20")	DISCO 21/D	A = 510 B = 56	4	∅ 36	5900
Disco dentato 510 (20")	DISCO 29/D	A = 510 B = 59	4	∅ 67	5900
Disco dentato 510 (20")	DISCO 38/D	A = 510 B = 59	3,25	∅ 31	4700
Disco dentato 560 (22")	DISCO 07/D	A = 560 B = 71	4,5	∅ 26	7600
Disco dentato 560 (22")	DISCO 08/D	A = 560 B = 71	4,5	∅ 31	7600

Tutti i modelli sono di nostra produzione e non originali.
 All models are of our manufacture and are not original.
 Alle unsere Landwirtschaftliche erzeugnisse sind unsere produktion und sind nicht original.
 Tous les modèles sont notre production et ne sont pas des produits d'origine.
 Все модели нашего производства и не являются оригинальными.

N.B. Pesi e misure sopra descritti sono puramente indicativi.
 N.B. The above weights and dimensions are given for reference only.
 N.B. Die obengenannten Gewichte und Abmessungen sind richtungsweisend.
 N.B. Les poids et les dimensions indiqués ci-dessus sont donnés à titre indicatif.
 N.B. Указанные вес и размеры, являются ориентировочными.

© La riproduzione
 anche parziale
 del presente catalogo
 è vietata.

DISCHI PER ERPICE, PER FRANGIZOLLE E PER SEMINATRICE
Discs for harrows ploughs and seeders
Disques pour herses, brise-mottes et semoirs
Scheiben für Eggen, Erdschollenbrecher und Sämaschine
Диски для дисковых борон и сеялок



Marca della macchina Machine brand name Marke der Maschine Marque de la machine Марка машины	Codice Nr. Ref. Nr. Re. Nr. Ref. Nr. Код №	Quote Dimensions Abmessungen Dimensions Размеры mm	Spessore Thickness Stärke Épaisseur Толщина mm	Fori Holes Löcher Trous Отверстие ∅ mm	Peso Weight Gewicht Poids Вес gr
--	--	---	---	---	---

DISCHI PER ERPICE
BOMBATI LISCI

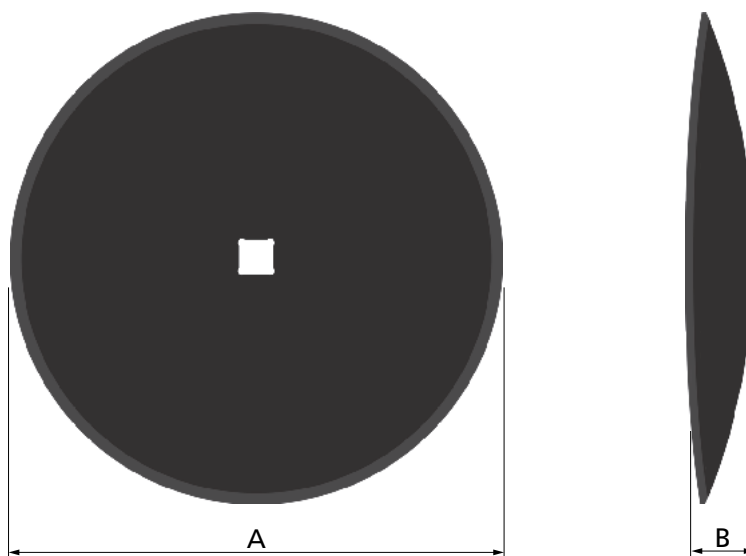

Disco liscio 460 (18")	DISCO 13/L	A = 460 B = 51	3,25	∅ 26	4200
Disco liscio 460 (18")	DISCO 14/L	A = 460 B = 51	3,25	∅ 31	4200
Disco liscio 510 (20")	DISCO 01/L	A = 510 B = 59	4	∅ 26	6500
Disco liscio 510 (20")	DISCO 02/L	A = 510 B = 59	4	∅ 31	6500
Disco liscio 510 (20")	DISCO 22/L	A = 510 B = 56	4	∅ 36	6500
Disco liscio 510 (20")	DISCO 28/L	A = 510 B = 59	4	∅ 67	6500
Disco liscio 510 (20")	DISCO 35/L	A = 510 B = 59	3,25	∅ 26	5100
Disco liscio 510 (20")	DISCO 36/L	A = 510 B = 59	3,25	∅ 31	5900

Tutti i modelli sono di nostra produzione e non originali.
 All models are of our manufacture and are not original.
 Alle unsere Landwirtschaftliche erzeugnisse sind unsere produktion und sind nicht original.
 Tous les modèles sont notre production et ne sont pas des produits d'origine.
 Все модели нашего производства и не являются оригинальными.

N.B. Pesi e misure sopra descritti sono puramente indicativi.
 N.B. The above weights and dimensions are given for reference only.
 N.B. Die obengenannten Gewichte und Abmessungen sind richtungsweisend.
 N.B. Les poids et les dimensions indiqués ci-dessus sont donnés à titre indicatif.
 N.B. Указанные вес и размеры, являются ориентировочными.

© La riproduzione
 anche parziale
 del presente catalogo
 è vietata.

DISCHI PER ERPICE, PER FRANGIZOLLE E PER SEMINATRICE

Discs for harrows ploughs and seeders

Disques pour herses, brise-mottes et semoirs

Scheiben für Eggen, Erdschollenbrecher und Sämaschine

Диски для дисковых борон и сеялок



Marca della macchina Machine brand name Marke der Maschine Marque de la machine Марка машины	Codice Nr. Ref. Nr. Re. Nr. Ref. Nr. Код №	Quote Dimensions Abmessungen Dimensions Размеры mm	Spessore Thickness Stärke Épaisseur Толщина mm	Fori Holes Löcher Trous Отверстие Ø mm	Peso Weight Gewicht Poids Вес gr
Disco liscio 560 (22")	DISCO 05/L	A = 560 B = 71	4,5	∅ 26	8600
Disco liscio 560 (22")	DISCO 06/L	A = 560 B = 71	4,5	∅ 31	8600
Disco liscio 560 (22")	DISCO 20/L	A = 560 B = 68	4,5	∅ 36	8600
Disco liscio 560 (22")	DISCO 24/L	A = 560 B = 71	4,5	∅ 67	7600
Disco liscio 610 (24")	DISCO 09/L	A = 610 B = 86	5	∅ 31	12000
Disco liscio 610 (24")	DISCO 10/L	A = 610 B = 86	5	∅ 41	12000
Disco liscio 610 (24")	DISCO 26/L	A = 610 B = 86	5	∅ 67	12000
Disco liscio 660 (26")	DISCO 33/L	A = 660 B = 97	6	∅ 5 fori	17500
Disco liscio 660 (26")	DISCO 51/L	A = 660 B = 97	6	∅ 41	17500
Disco liscio 710 (28")	DISCO 32/L	A = 710 B = 102	6	∅ 41	21000

DISCHI PER ERPICE, PER FRANGIZOLLE E PER SEMINATRICE
Discs for harrows ploughs and seeders
Disques pour herses, brise-mottes et semoirs
Scheiben für Eggen, Erdschollenbrecher und Sämaschine
Диски для дисковых борон и сеялок



Marca della macchina
 Machine brand name
 Marke der Maschine
 Marque de la machine
 Марка машины

Codice Nr.
 Ref. Nr.
 Re. Nr.
 Ref. Nr.
 Код №

Quote
 Dimensions
 Abmessungen
 Dimensions
 Размеры
 mm

Spessore
 Thickness
 Stärke
 Epaisseur
 Толщина
 mm

Fori
 Holes
 Löcher
 Trous
 Отверстие
 ø mm

Peso
 Weight
 Gewicht
 Poids
 Вес
 gr

**DISCHI PER ERPICE
 E SEMINATRICI**

Lemken/Rubin
Disco dentato 625x6
3490467

Disco 108/D

A = 625
 B = 60

Spessore 6

5 fori 12,5

12600

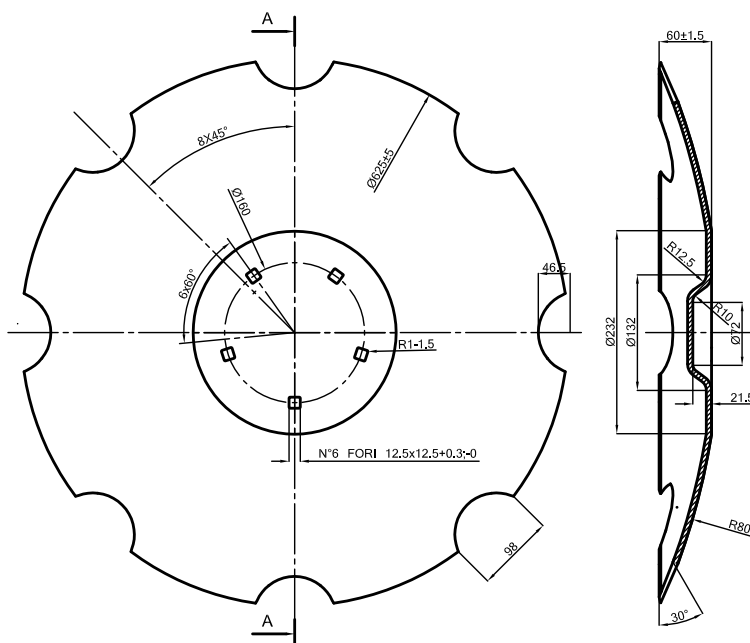
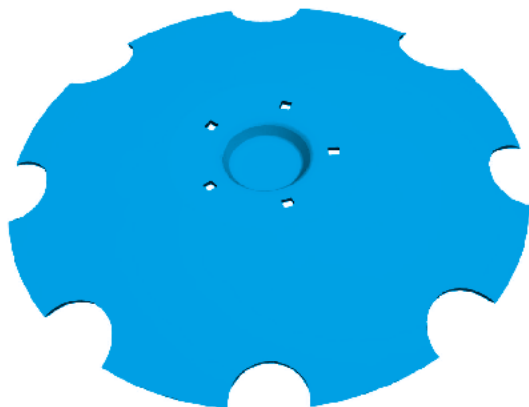

Lemken/Rubin
Disco dentato 625x6
3490466

Disco 109/D

A = 625
 B = 65

Spessore 6

6 fori 12,5

13200

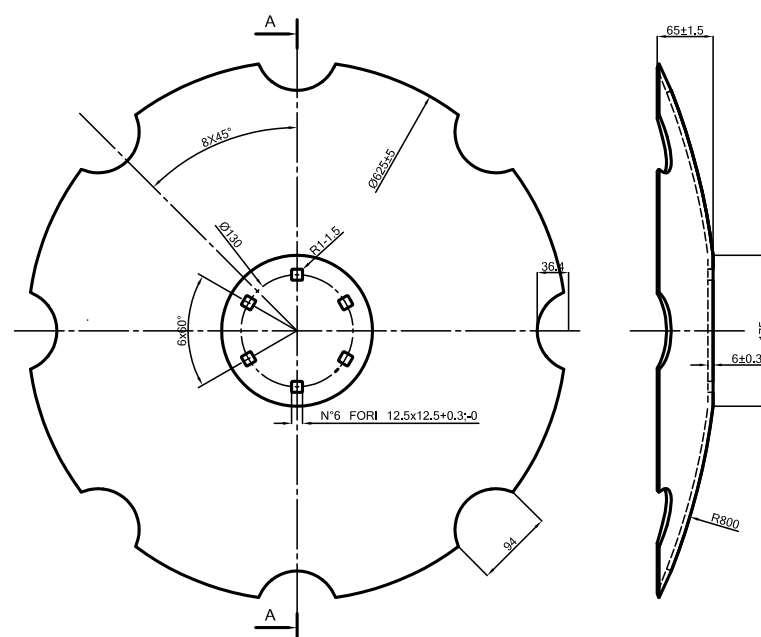
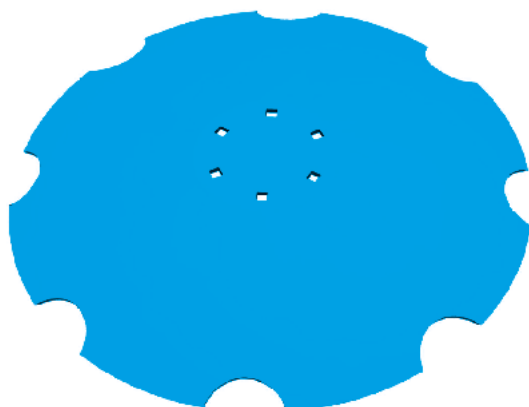

Tutti i modelli sono di nostra produzione e non originali.
 All models are of our manufacture and are not original.
 Alle unsere Landwirtschaftliche erzeugnisse sind unsere produktion und sind nicht original.
 Tous les modèles sont notre production et ne sont pas des produits d'origine.
 Все модели нашего производства и не являются оригинальными.

N.B. Pesi e misure sopra descritti sono puramente indicativi.
 N.B. The above weights and dimensions are given for reference only.
 N.B. Die obengenannten Gewichte und Abmessungen sind richtungsweisend.
 N.B. Les poids et les dimensions indiqués ci-dessus sont donnés à titre indicatif.
 N.B. Указанные вес и размеры, являются ориентировочными.

© La riproduzione
 anche parziale
 del presente catalogo
 è vietata.

DISCHI PER ERPICE, PER FRANGIZOLLE E PER SEMINATRICE
Discs for harrows ploughs and seeders
Disques pour herses, brise-mottes et semoirs
Scheiben für Eggen, Erdschollenbrecher und Sämaschine
Диски для дисковых борон и сеялок



Marca della macchina
Machine brand name
Marke der Maschine
Marque de la machine
Марка машины

Codice Nr.
Ref. Nr.
Re. Nr.
Ref. Nr.
Код №

Quote
Dimensions
Abmessungen
Dimensions
Размеры
mm

Spessore
Thickness
Stärke
Épaisseur
Толщина
mm

Fori
Holes
Löcher
Trous
Отверстие
Ø mm

Peso
Weight
Gewicht
Poids
Вес
gr

Horsch
Disco dentato 460×4
23246102

Disco 118/D

A = 460
B = 50

Spessore 4

3 fori 13

4470

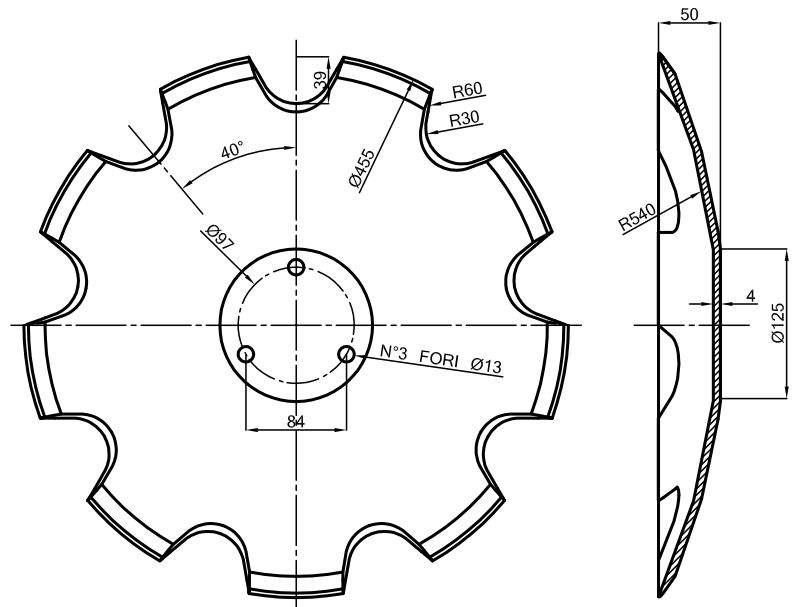

Horsch
Disco dentato 460×6
23246103

Disco 119/D

A = 460
B = 52

Spessore 6

3 fori 13

6670

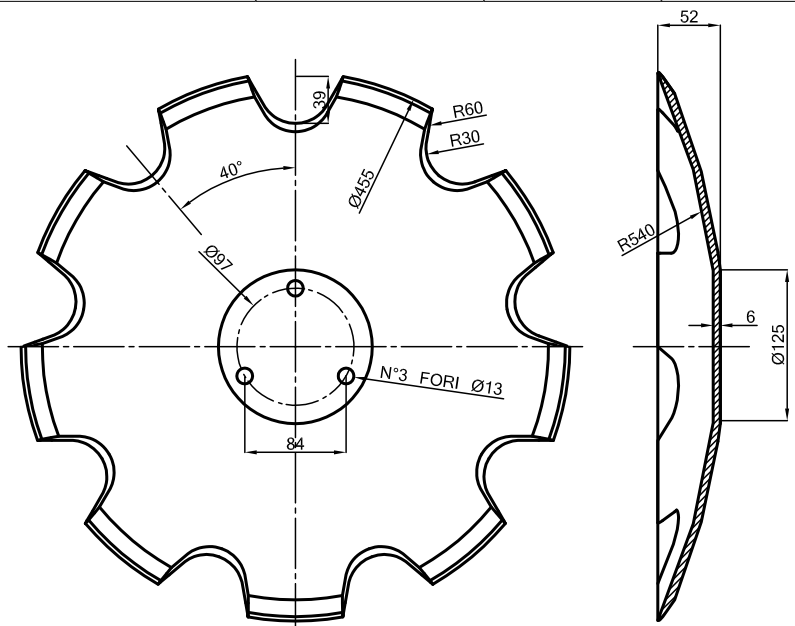

DISCHI PER ERPICE, PER FRANGIZOLLE E PER SEMINATRICE
Discs for harrows ploughs and seeders
Disques pour herses, brise-mottes et semoirs
Scheiben für Eggen, Erdschollenbrecher und Sämaschine
Диски для дисковых борон и сеялок



Marca della macchina Machine brand name Marke der Maschine Marque de la machine Марка машины	Codice Nr. Ref. Nr. Re. Nr. Ref. Nr. Код №	Quote Dimensions Abmessungen Dimensions Размеры mm	Spessore Thickness Stärke Épaisseur Толщина mm	Fori Holes Löcher Trous Отверстия Ø mm	Peso Weight Gewicht Poids Вес gr
--	--	---	---	---	---

Amazone Disco liscio 325x3 962292	Disco 120/L	A = 325 B = 22	Spessore 3	∅ 3 fori 10,5x19	1865
--	-------------	-------------------	------------	------------------------	------

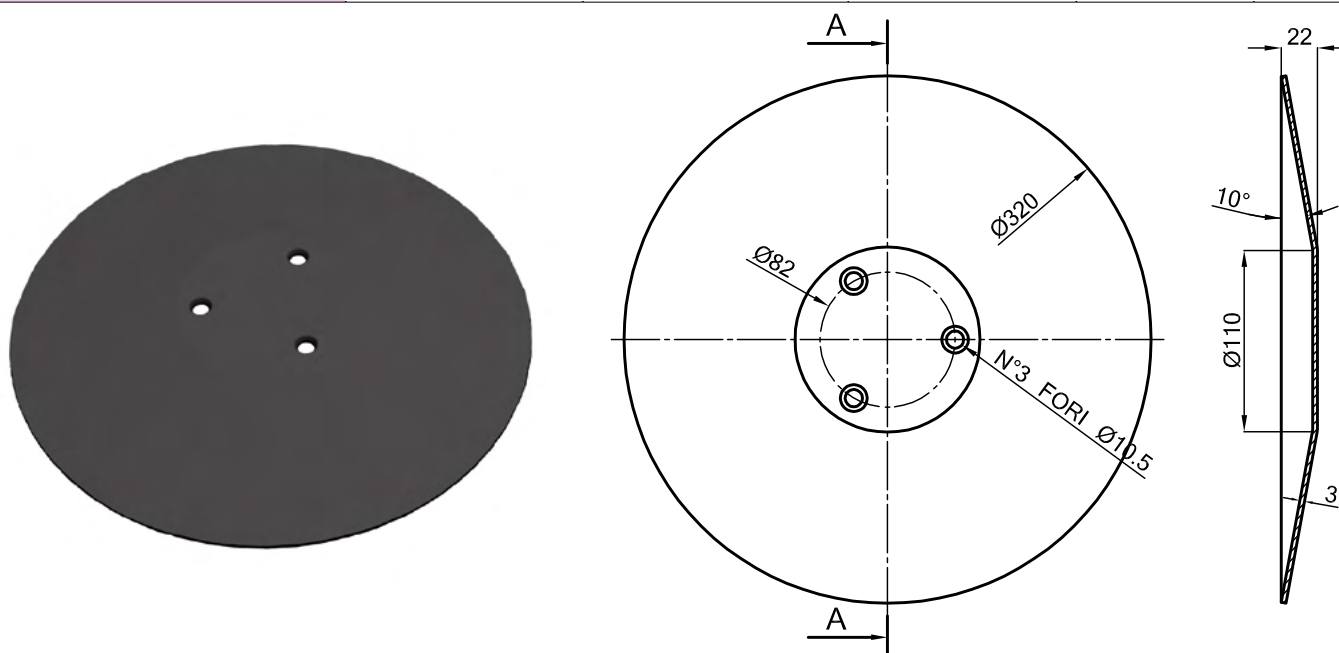

Amazone Disco liscio 460x4 XL011	Disco 121/L	A = 460 B = 44	Spessore 4	∅ 4 fori 12,5	5300
---	-------------	-------------------	------------	------------------	------

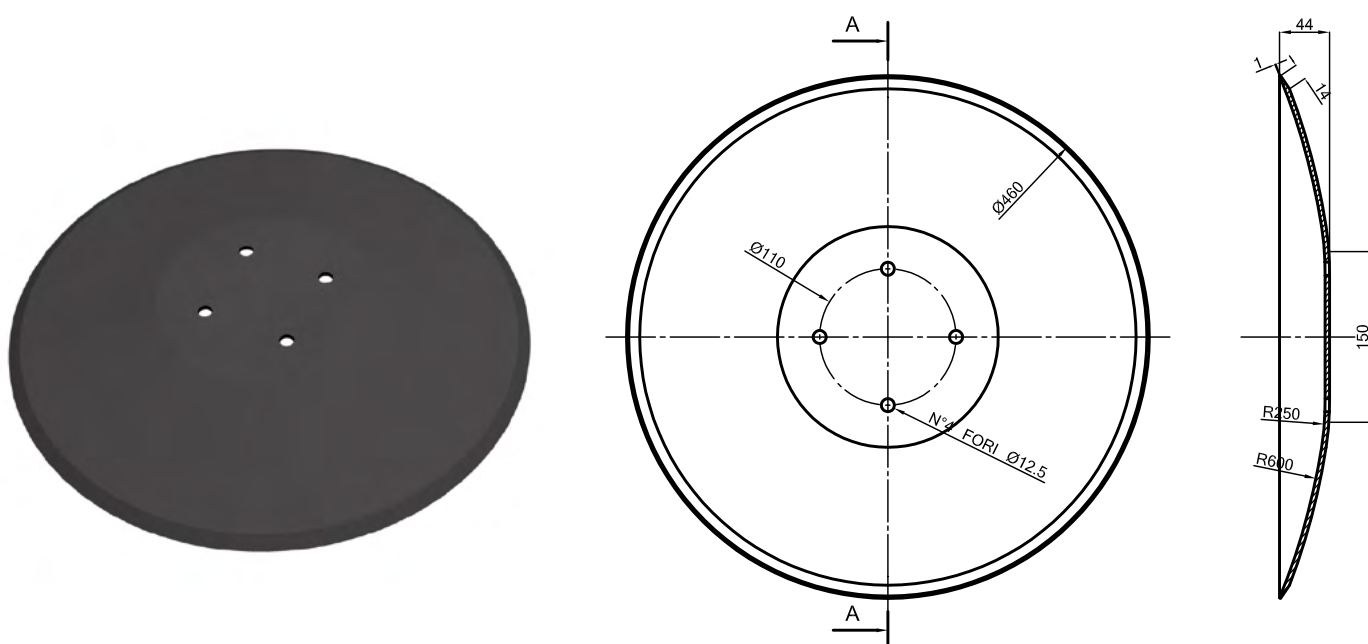

Tutti i modelli sono di nostra produzione e non originali.
 All models are of our manufacture and are not original.
 Alle unsere Landwirtschaftliche erzeugnisse sind unsere produktion und sind nicht original.
 Tous les modèles sont notre production et ne sont pas des produits d'origine.
 Все модели нашего производства и не являются оригинальными.

N.B. Pesi e misure sopra descritti sono puramente indicativi.
 N.B. The above weights and dimensions are given for reference only.
 N.B. Die obengenannten Gewichte und Abmessungen sind richtungsweisend.
 N.B. Les poids et les dimensions indiqués ci-dessus sont donnés à titre indicatif.
 N.B. Указанные вес и размеры, являются ориентировочными.

© La riproduzione
 anche parziale
 del presente catalogo
 è vietata.

DISCHI PER ERPICE, PER FRANGIZOLLE E PER SEMINATRICE
Discs for harrows ploughs and seeders
Disques pour herses, brise-mottes et semoirs
Scheiben für Eggen, Erdschollenbrecher und Sämaschine
Диски для дисковых борон и сеялок



Marca della macchina
Machine brand name
Marke der Maschine
Marque de la machine
Марка машины

Codice Nr.
Ref. Nr.
Re. Nr.
Ref. Nr.
Код №

Quote
Dimensions
Abmessungen
Dimensions
Размеры
mm

Spessore
Thickness
Stärke
Épaisseur
Толщина
mm

Fori
Holes
Löcher
Trous
Отверстия
Ø mm

Peso
Weight
Gewicht
Poids
Вес
gr

Amazone Disco liscio 460x4 XL041	Disco 122/L	A = 460 B = 42	Spessore 4	4 fori 11,5	5060
---	-------------	-------------------	------------	-------------	------

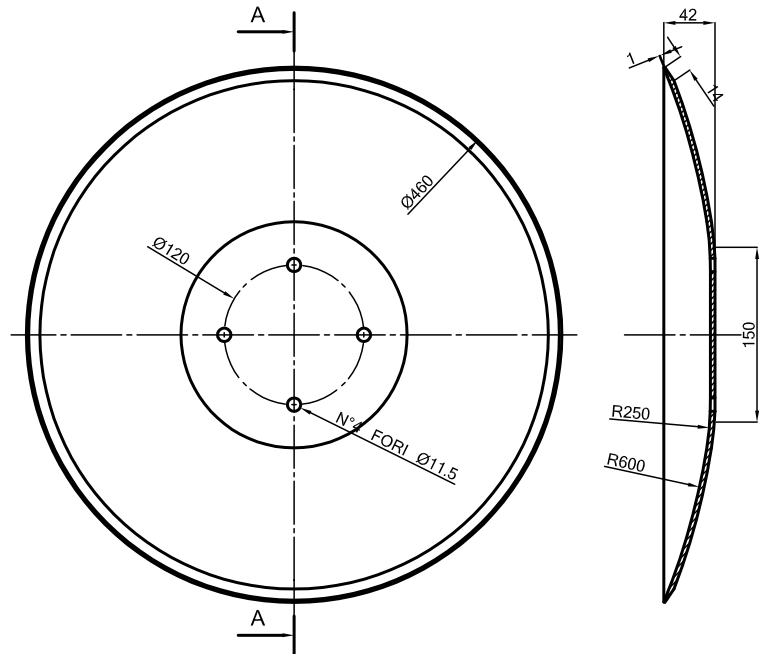

Vaderstad Disco dentato 410x5 451372	Disco 123/D	A = 410 B = 13	Spessore 5	5 fori 12,5	4360
---	-------------	-------------------	------------	-------------	------

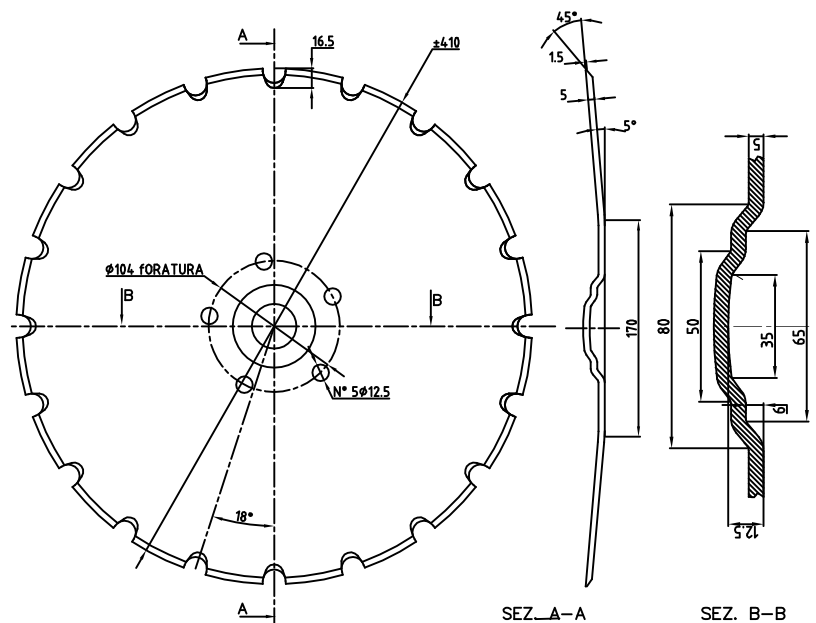

DISCHI PER ERPICE, PER FRANGIZOLLE E PER SEMINATRICI
Discs for harrows ploughs and seeders
Disques pour herses, brise-mottes et semoirs
Scheiben für Eggen, Erdschollenbrecher und Sämaschine
Диски для дисковых борон и сеялок



Marca della macchina Machine brand name Marke der Maschine Marque de la machine Марка машины	Codice Nr. Ref. Nr. Re. Nr. Ref. Nr. Код №	Quote Dimensions Abmessungen Dimensions Размеры mm	Spessore Thickness Stärke Epaisseur Толщина mm	Fori Holes Löcher Trous Отверстие ø mm	Peso Weight Gewicht Poids Вес gr
--	--	---	---	---	---

Vaderstad Disco dentato 430x5 459608	Disco 124D/430	A = 430 B = 36	Spessore 5	∅ 4 fori 12,5	5250
---	----------------	-------------------	------------	------------------	------

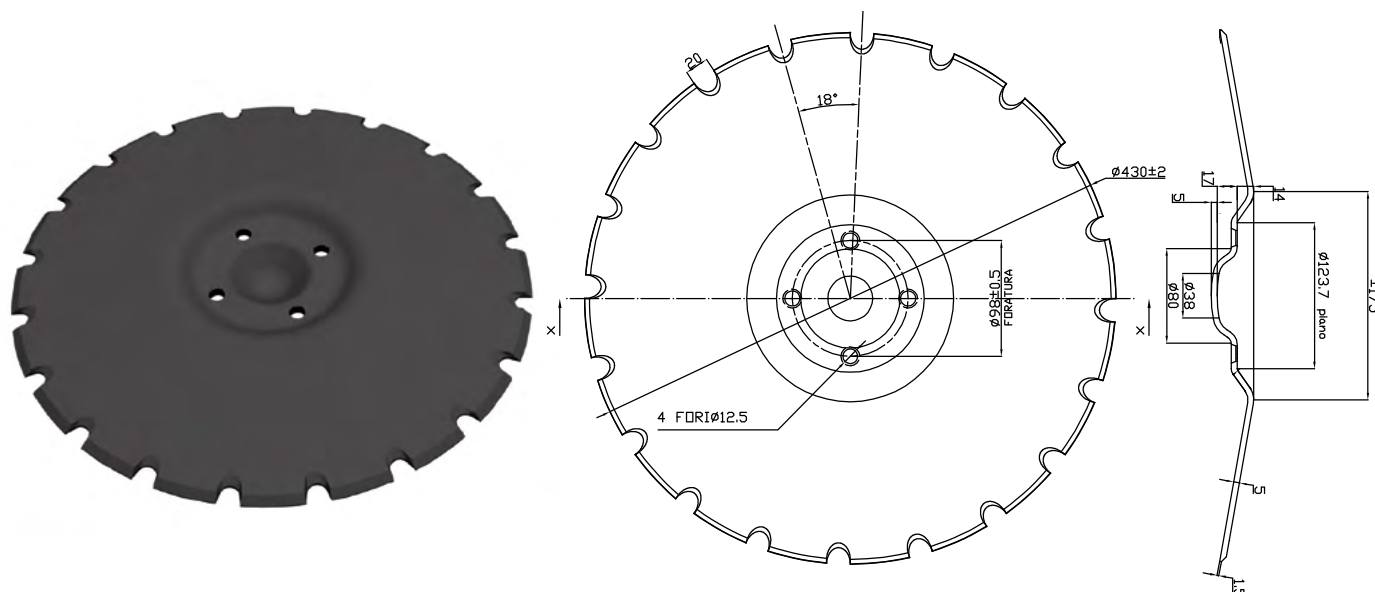

Vaderstad Disco dentato 450x5 466947	Disco 124D/450	A = 450 B = 36	Spessore 5	∅ 4 fori 12,5	6000
---	----------------	-------------------	------------	------------------	------

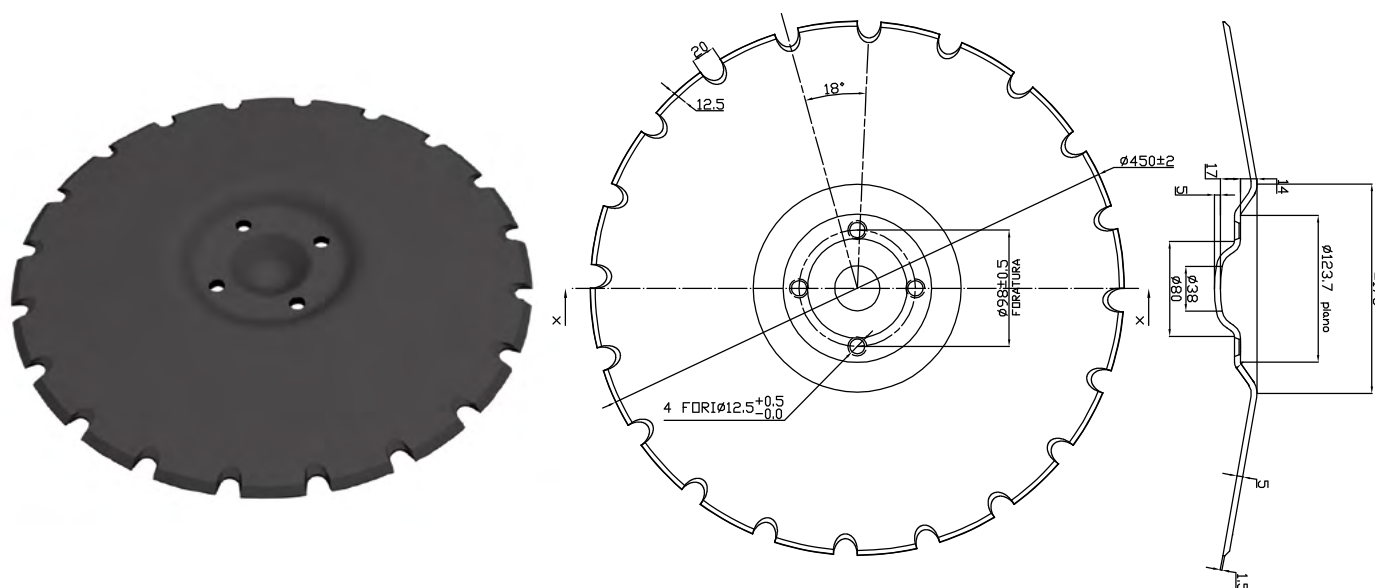

Tutti i modelli sono di nostra produzione e non originali.
 All models are of our manufacture and are not original.
 Alle unsere Landwirtschaftliche erzeugnisse sind unsere produktion und sind nicht original.
 Tous les modèles sont notre production et ne sont pas des produits d'origine.
 Все модели нашего производства и не являются оригинальными.

N.B. Pesi e misure sopra descritti sono puramente indicativi.
 N.B. The above weights and dimensions are given for reference only.
 N.B. Die obengenannten Gewichte und Abmessungen sind richtungsweisend.
 N.B. Les poids et les dimensions indiqués ci-dessus sont donnés à titre indicatif.
 N.B. Указанные вес и размеры, являются ориентировочными.

© La riproduzione
 anche parziale
 del presente catalogo
 è vietata.

DISCHI PER ERPICE, PER FRANGIZOLLE E PER SEMINATRICE
Discs for harrows ploughs and seeders
Disques pour herses, brise-mottes et semoirs
Scheiben für Eggen, Erdschollenbrecher und Sämaschine
Диски для дисковых борон и сеялок



Marca della macchina
 Machine brand name
 Marke der Maschine
 Marque de la machine
 Марка машины

Codice Nr.
 Ref. Nr.
 Re. Nr.
 Ref. Nr.
 Код №

Quote
 Dimensions
 Abmessungen
 Dimensions
 Размеры
 mm

Spessore
 Thickness
 Stärke
 Epaisseur
 Толщина
 mm

Fori
 Holes
 Löcher
 Troux
 Отверстие
 ø mm

Peso
 Weight
 Gewicht
 Poids
 Вес
 gr

Vaderstad
Disco dentato 410x5 (16")
451371

Disco 125/D

A = 410

Spessore 5

5 fori 12,5

4600

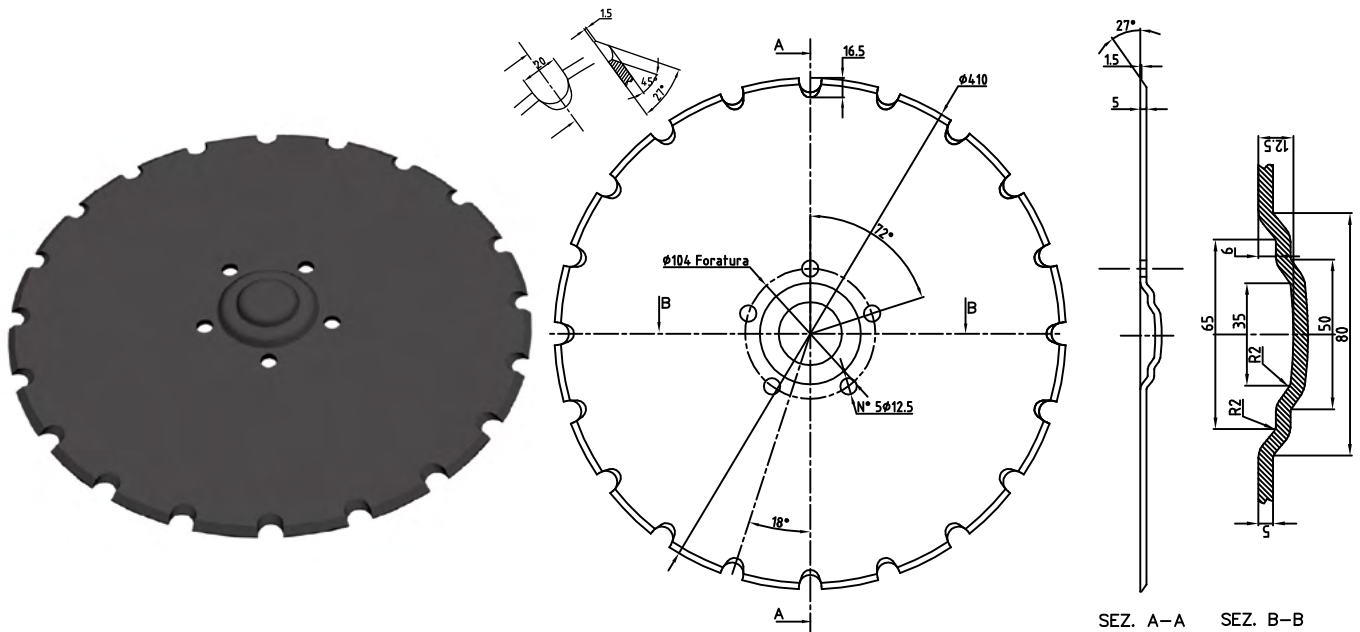

Disco ondulato dentato
507x4

Disco 600/D

A = 507
 B = 58

Spessore 4

31

5900

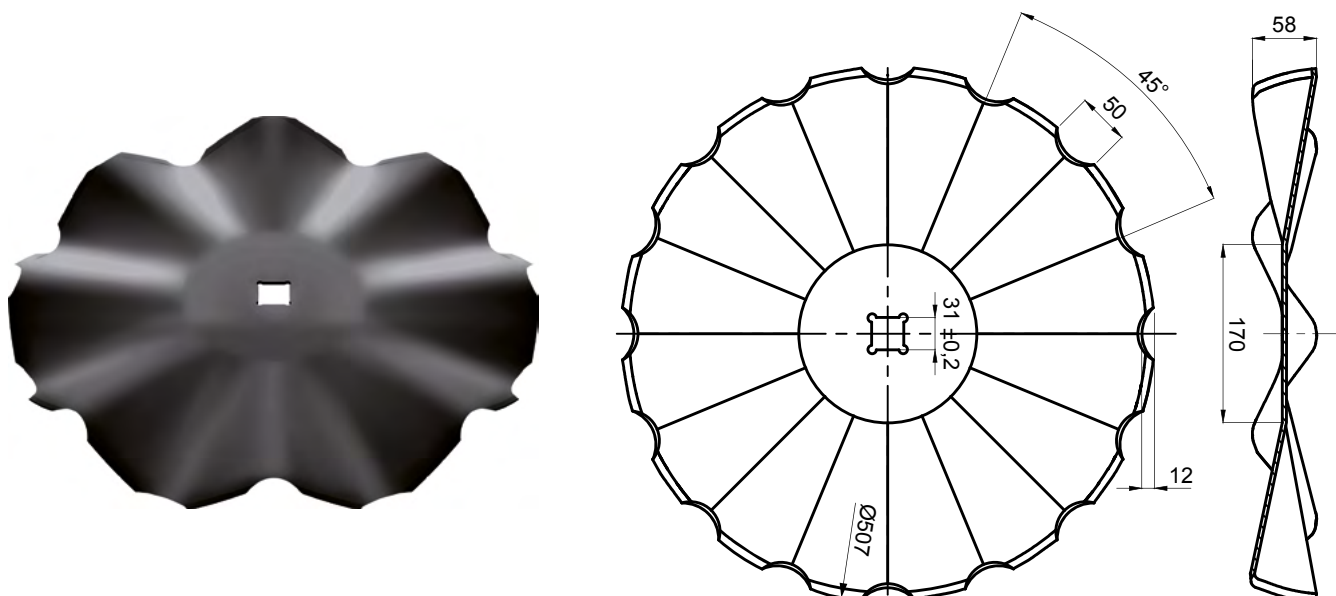

DISCHI PER ERPICE, PER FRANGIZOLLE E PER SEMINATRICE
Discs for harrows ploughs and seeders
Disques pour herses, brise-mottes et semoirs
Scheiben für Eggen, Erdschollenbrecher und Sämaschine
Диски для дисковых борон и сеялок



Marca della macchina Machine brand name Marke der Maschine Marque de la machine Марка машины	Codice Nr. Ref. Nr. Re. Nr. Ref. Nr. Код №	Quote Dimensions Abmessungen Dimensions Размеры mm	Spessore Thickness Stärke Épaisseur Толщина mm	Fori Holes Löcher Trous Отверстие ø mm	Peso Weight Gewicht Poids Вес gr
--	--	---	---	---	---

Disco ondulato liscio 507x4	Disco 600/L	A = 507 B = 58	Spessore 4	31	6580
--	-------------	-------------------	------------	----	------

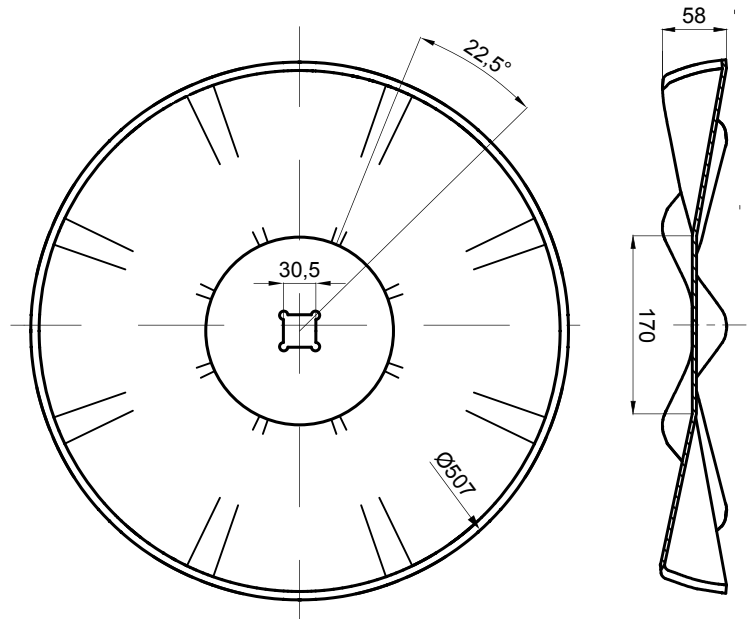
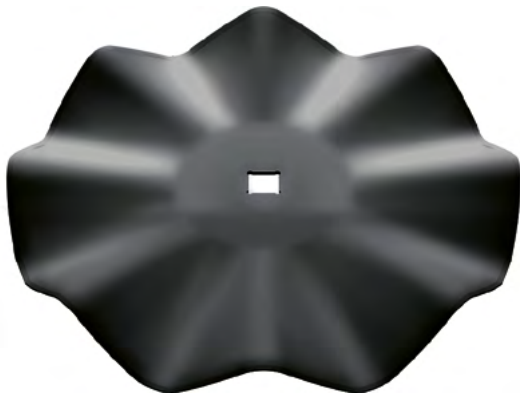





eurozappa

RASCHIETTI

Scraper

Schaber

Grattoirs

Скребки





RASCHIETTI
Scraper
Schaber
Grattoirs
Скребки



Marca della macchina Machine brand name Marke der Maschine Marque de la machine Марка машины	Tipo e codice originale Type and original code Typ original hersteller Type et code d'origine Тип и оригинальный код	Codice Nr. Ref. Nr. Re. Nr. Ref. Nr. Код №	Marca della macchina Machine brand name Marke der Maschine Marque de la machine Марка машины	Tipo e codice originale Type and original code Typ original hersteller Type et code d'origine Тип и оригинальный код	Codice Nr. Ref. Nr. Re. Nr. Ref. Nr. Код №
--	--	--	--	--	--

RICAMBIO NON ORIGINALE PER ALPEGO	PULIRULLO PK	113016	RICAMBIO NON ORIGINALE PER ALPEGO	PULIRULLO PK N.T.	113027
	D01308	gr 260 80×3		D01308S	gr 210 80×3

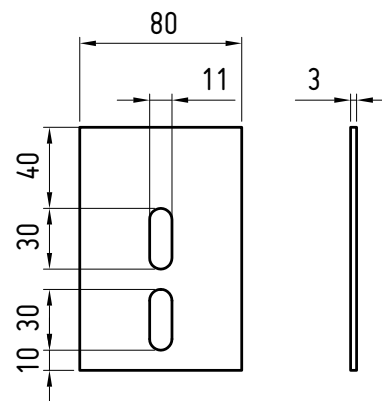
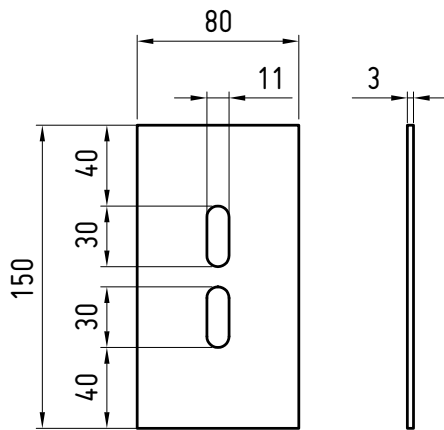

RICAMBIO NON ORIGINALE PER AMAZONE	6036200	60362	RICAMBIO NON ORIGINALE PER AMAZONE	60402
	603600	gr 160 55×3		60402

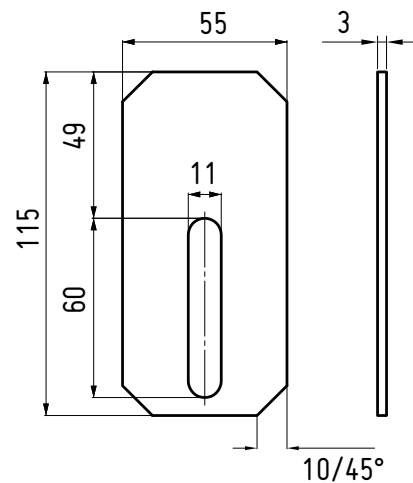
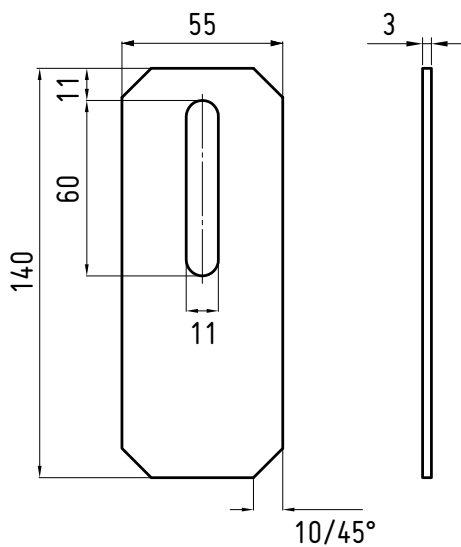

Tutti i modelli sono di nostra produzione e non originali.
 All models are of our manufacture and are not original.
 Alle unsere Landwirtschaftliche erzeugnisse sind unsere produktion und sind nicht original.
 Tous les modèles sont notre production et ne sont pas des produits d'origine.
 Все модели нашего производства и не являются оригинальными.

N.B. Pesi e misure sopra descritti sono puramente indicativi.
 N.B. The above weights and dimensions are given for reference only.
 N.B. Die obengenannten Gewichte und Abmessungen sind richtungsweisend.
 N.B. Les poids et les dimensions indiqués ci-dessus sont donnés à titre indicatif.
 N.B. Указанные вес и размеры, являются ориентировочными.

© La riproduzione
 anche parziale
 del presente catalogo
 è vietata.

RASCHIETTI
Scraper
Schaber
Grattoirs
Скребки



Marca della macchina
 Machine brand name
 Marke der Maschine
 Marque de la machine
 Марка машины

Tipo e codice originale
 Type and original code
 Typ original hersteller
 Type et code d'origine
 Тип и оригинальный код

Codice Nr.
 Ref. Nr.
 Re. Nr.
 Ref. Nr.
 Код №

Marca della macchina
 Machine brand name
 Marke der Maschine
 Marque de la machine
 Марка машины

Tipo e codice originale
 Type and original code
 Typ original hersteller
 Type et code d'origine
 Тип и оригинальный код

Codice Nr.
 Ref. Nr.
 Re. Nr.
 Ref. Nr.
 Код №

RICAMBIO NON ORIGINALE PER AMAZONE		AMAZONE 01	RICAMBIO NON ORIGINALE PER BREVIGLIERI	RASCHIARULLO	134501
		gr 210			gr 400
	6081200	90×3		60500	90×4

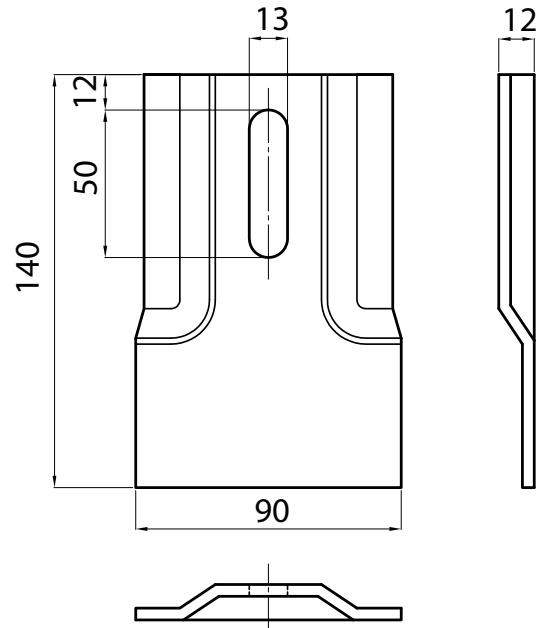
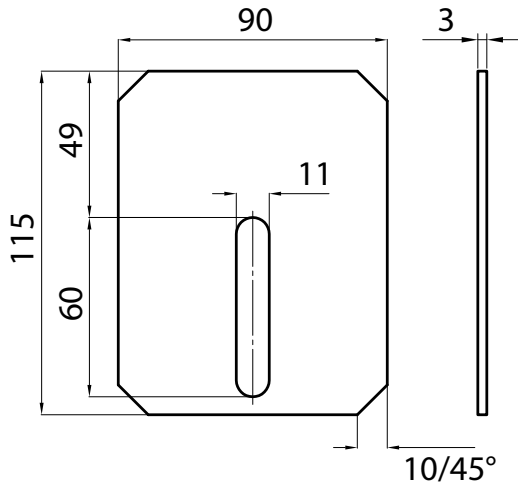

RICAMBIO NON ORIGINALE PER BREVIGLIERI	RASCHIARULLO	134502	RICAMBIO NON ORIGINALE PER BREVIGLIERI	RASCHIARULLO	134503
		gr 365			gr 420
	32811	80×4		3178974	100×3

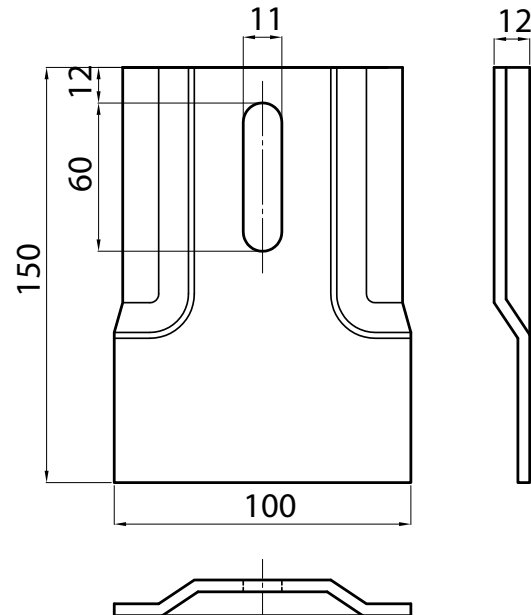
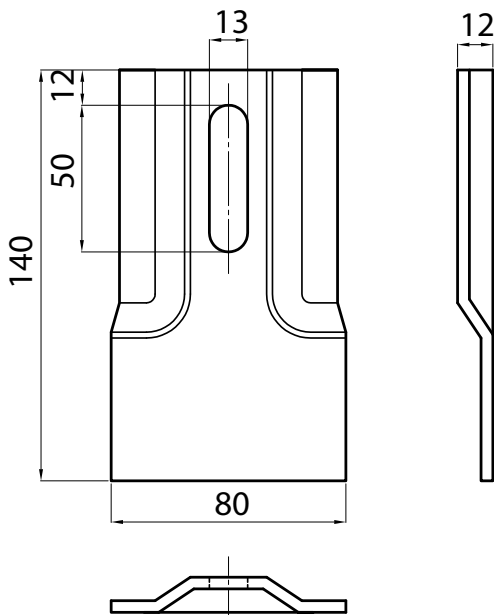

RASCHIETTI
Scraper
Schaber
Grattoirs
Скребки



Marca della macchina Machine brand name Marke der Maschine Marque de la machine Марка машины	Tipo e codice originale Type and original code Typ original hersteller Type et code d'origine Тип и оригинальный код	Codice Nr. Ref. Nr. Re. Nr. Ref. Nr. Код №	Marca della macchina Machine brand name Marke der Maschine Marque de la machine Марка машины	Tipo e codice originale Type and original code Typ original hersteller Type et code d'origine Тип и оригинальный код	Codice Nr. Ref. Nr. Re. Nr. Ref. Nr. Код №
RICAMBIO NON ORIGINALE PER CELLI		153052	RICAMBIO NON ORIGINALE PER EBERHARDT		174501
		gr 330			gr 500
	911601	100×3		300142	90×5

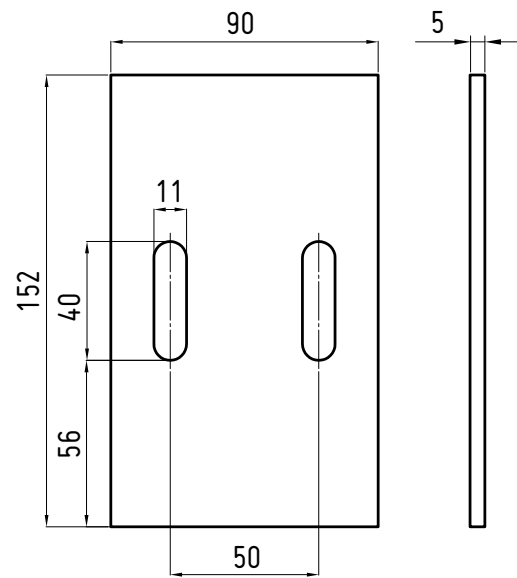
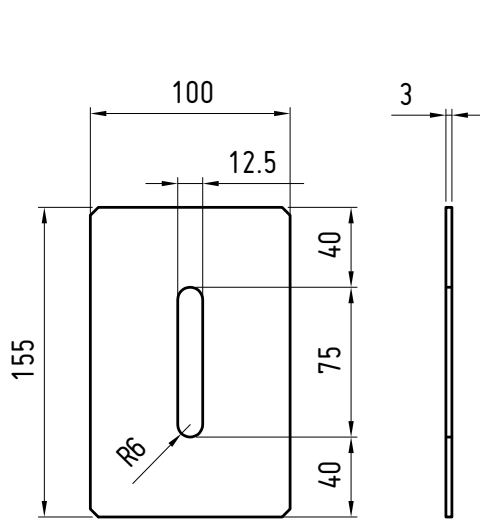

RICAMBIO NON ORIGINALE PER EBERHARDT		174502	RICAMBIO NON ORIGINALE PER FALC		181039
		gr 360			gr 270
		90×3		543001	90×3

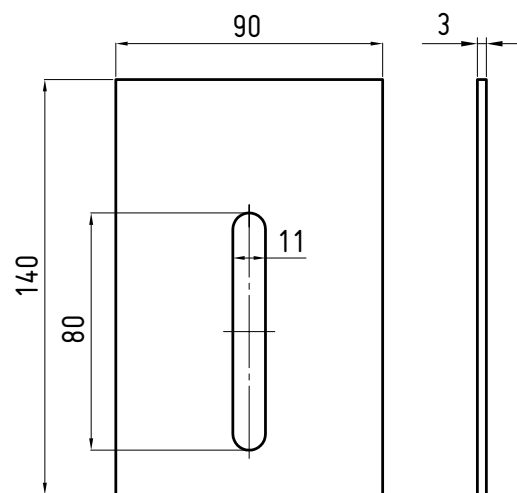
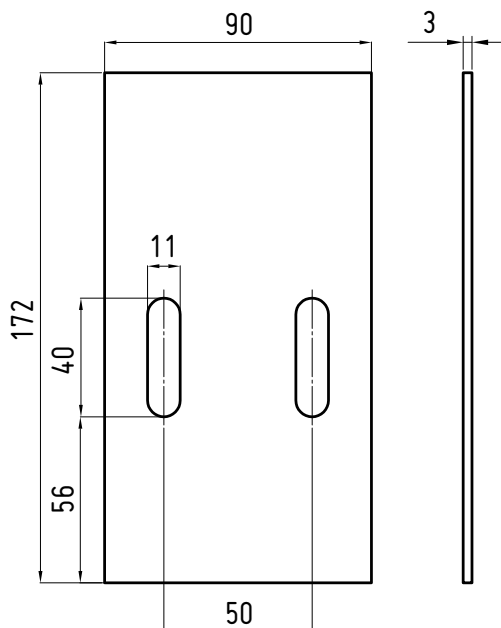

Tutti i modelli sono di nostra produzione e non originali.
 All models are of our manufacture and are not original.
 Alle unsere Landwirtschaftliche erzeugnisse sind unsere produktion und sind nicht original.
 Tous les modèles sont notre production et ne sont pas des produits d'origine.
 Все модели нашего производства и не являются оригинальными.

N.B. Pesi e misure sopra descritti sono puramente indicativi.
 N.B. The above weights and dimensions are given for reference only.
 N.B. Die obengenannten Gewichte und Abmessungen sind richtungsweisend.
 N.B. Les poids et les dimensions indiqués ci-dessus sont donnés à titre indicatif.
 N.B. Указанные вес и размеры, являются ориентировочными.

© La riproduzione
 anche parziale
 del presente catalogo
 è vietata.

RASCHIETTI
Scraper
Schaber
Grattoirs
Скребки



Marca della macchina
 Machine brand name
 Marke der Maschine
 Marque de la machine
 Марка машины

Tipo e codice originale
 Type and original code
 Typ original hersteller
 Type original hersteller
 Type et code d'origine
 Тип и оригинальный код

Codice Nr.
 Ref. Nr.
 Re. Nr.
 Ref. Nr.
 Код №

Marca della macchina
 Machine brand name
 Marche des machine
 Marque de la machine
 Марка машины

Tipo e codice originale
 Type and original code
 Typ original hersteller
 Type original hersteller
 Type et code d'origine
 Тип и оригинальный код

Codice Nr.
 Ref. Nr.
 Re. Nr.
 Ref. Nr.
 Код №

RICAMBIO NON ORIGINALE PER FERABOLI	RASCHIATORE	180002	RICAMBIO NON ORIGINALE PER FERABOLI		646710
	48921	gr 250 90×3		646710	gr 150 70×3

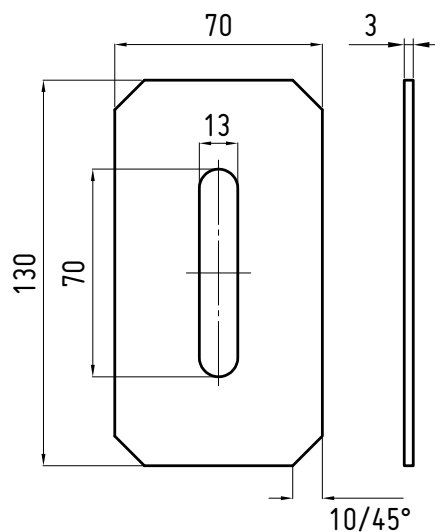
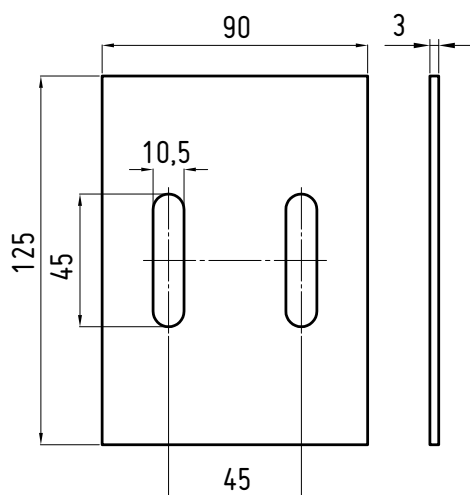

RICAMBIO NON ORIGINALE PER FERABOLI		808501	RICAMBIO NON ORIGINALE PER GASPARDO		203005
		gr 250 90×3		G15322910	gr 550 70×8

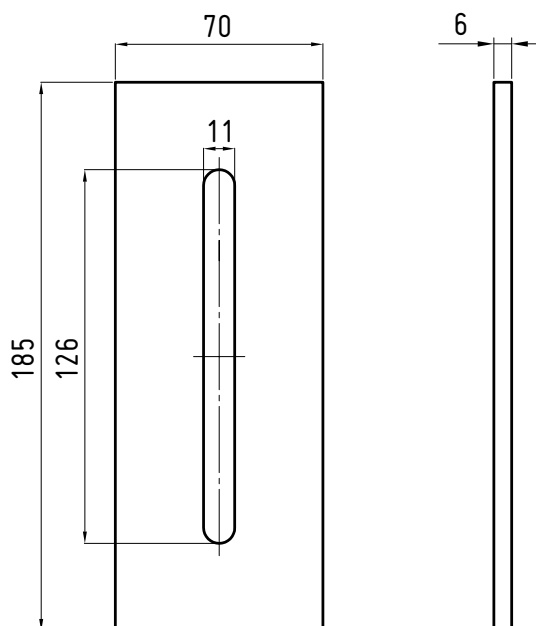
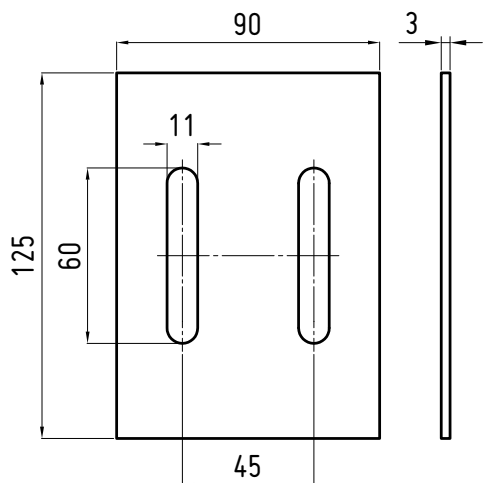

RASCHIETTI
Scraper
Schaber
Grattoirs
Скребки



Marca della macchina Machine brand name Marke der Maschine Marque de la machine Марка машины	Tipo e codice originale Type and original code Typ original hersteller Type et code d'origine Тип и оригинальный код	Codice Nr. Ref. Nr. Re. Nr. Ref. Nr. Код №	Marca della macchina Machine brand name Marke der Maschine Marque de la machine Марка машины	Tipo e codice originale Type and original code Typ original hersteller Type et code d'origine Тип и оригинальный код	Codice Nr. Ref. Nr. Re. Nr. Ref. Nr. Код №
RICAMBIO NON ORIGINALE PER HOWARD		225501	RICAMBIO NON ORIGINALE PER HOWARD		225502
	652882	gr 210		653579	gr 185
		100×3			80×3

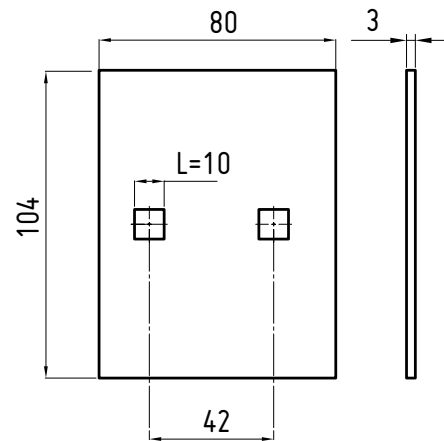
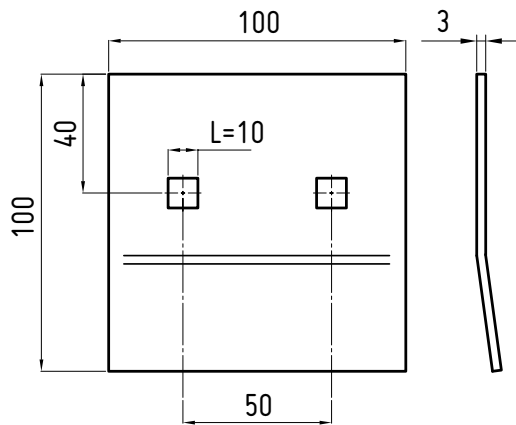

RICAMBIO NON ORIGINALE PER KRONE		236501	RICAMBIO NON ORIGINALE PER KRONE		803701
		gr 230		4904235	gr 180
		85×3			68×3

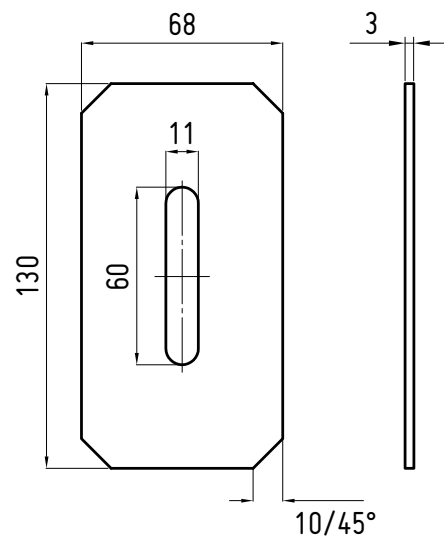
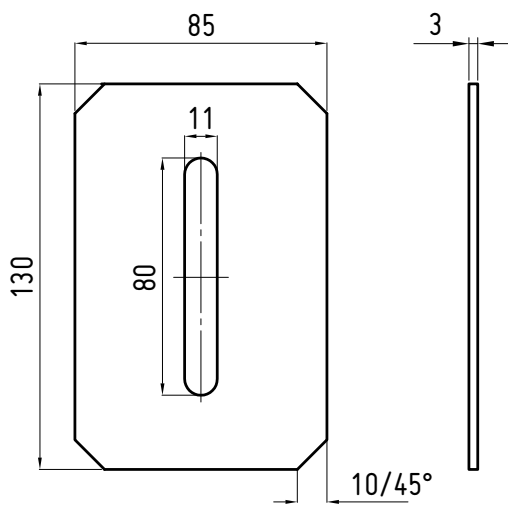

RASCHIETTI
Scraper
Schaber
Grattoirs
Скребки



Marca della macchina
 Machine brand name
 Marke der Maschine
 Marque de la machine
 Марка машины

Tipo e codice originale
 Type and original code
 Typ original hersteller
 Type et code d'origine
 Тип и оригинальный код

Codice Nr.
 Ref. Nr.
 Re. Nr.
 Ref. Nr.
 Код №

Marca della macchina
 Machine brand name
 Marche des machine
 Marque de la machine
 Марка машины

Tipo e codice originale
 Type and original code
 Typ original hersteller
 Type et code d'origine
 Тип и оригинальный код

Codice Nr.
 Ref. Nr.
 Re. Nr.
 Ref. Nr.
 Код №

RICAMBIO NON ORIGINALE PER KRONE		803702	RICAMBIO NON ORIGINALE PER KUHN		237031
		gr 260			gr 240
	4907612	98x3		52532130	75x3

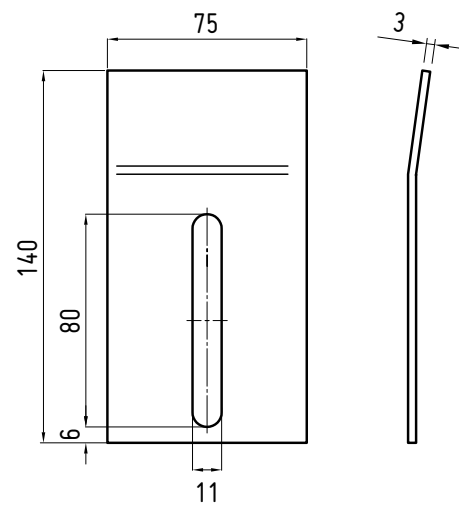
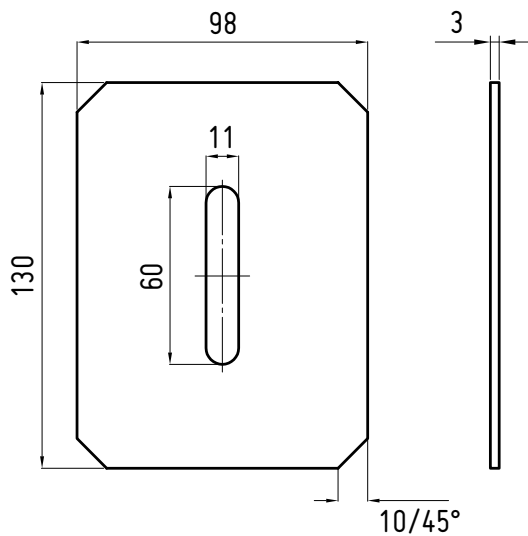

RICAMBIO NON ORIGINALE PER KUHN		237501	RICAMBIO NON ORIGINALE PER KUHN		237502
		gr 380			gr 550
	525.321.20	75x5			90x5

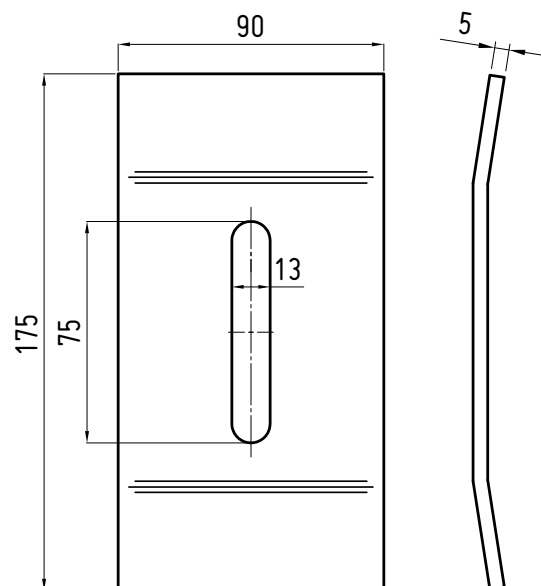
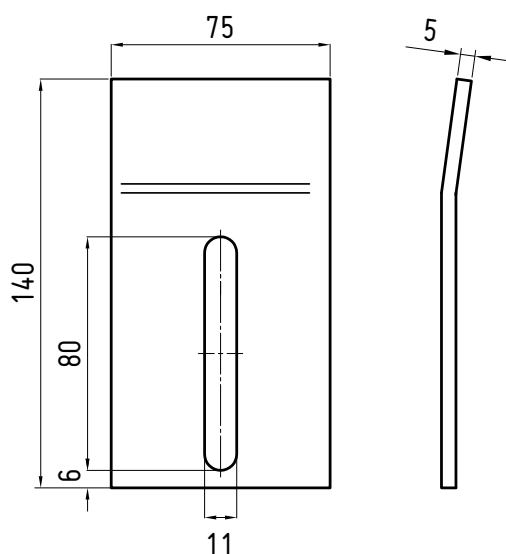

RASCHIETTI
Scraper
Schaber
Grattoirs
Скребки



Marca della macchina
 Machine brand name
 Marke der Maschine
 Marque de la machine
 Марка машины

Tipo e codice originale
 Type and original code
 Typ original hersteller
 Type et code d'origine
 Тип и оригинальный код

Codice Nr.
 Ref. Nr.
 Re. Nr.
 Ref. Nr.
 Код №

Marca della macchina
 Machine brand name
 Marche des machine
 Marque de la machine
 Марка машины

Tipo e codice originale
 Type and original code
 Typ original hersteller
 Type et code d'origine
 Тип и оригинальный код

Codice Nr.
 Ref. Nr.
 Re. Nr.
 Ref. Nr.
 Код №

RICAMBIO NON ORIGINALE PER KUHN		237503	RICAMBIO NON ORIGINALE PER KVERNELAND		252057
		gr 240			gr 250
	525.321.30	75x3		8007090	90x3

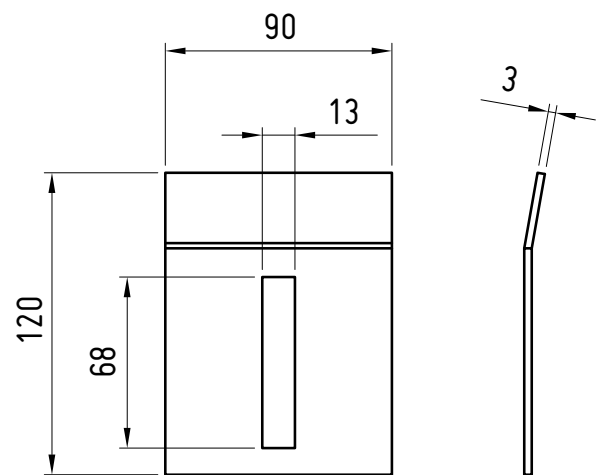
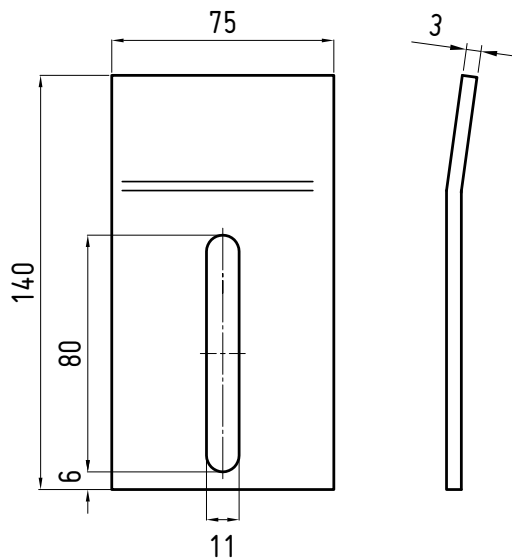

RICAMBIO NON ORIGINALE PER KVERNELAND		252058	RICAMBIO NON ORIGINALE PER KVERNELAND		252082
		gr 210			gr 510
	8006090	75x3		8008090	105x4

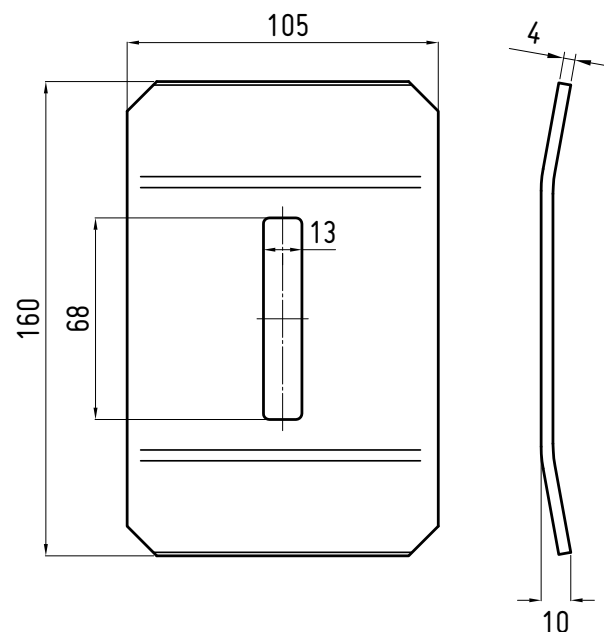
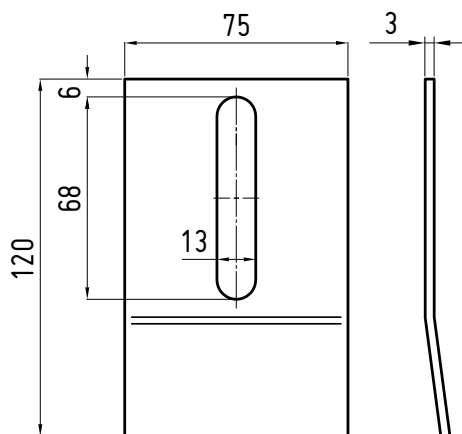

Tutti i modelli sono di nostra produzione e non originali.
 All models are of our manufacture and are not original.
 Alle unsere Landwirtschaftliche erzeugnisse sind unsere produktion und sind nicht original.
 Tous les modèles sont notre production et ne sont pas des produits d'origine.
 Все модели нашего производства и не являются оригинальными.

N.B. Pesi e misure sopra descritti sono puramente indicativi.
 N.B. The above weights and dimensions are given for reference only.
 N.B. Die obengenannten Gewichte und Abmessungen sind richtungsweisend.
 N.B. Les poids et les dimensions indiqués ci-dessus sont donnés à titre indicatif.
 N.B. Указанные вес и размеры, являются ориентировочными.

© La riproduzione
 anche parziale
 del presente catalogo
 è vietata.

RASCHIETTI
Scraper
Schaber
Grattoirs
Скребки



Marca della macchina Machine brand name Marke der Maschine Marque de la machine Марка машины	Tipo e codice originale Type and original code Typ original hersteller Type et code d'origine Тип и оригинальный код	Codice Nr. Ref. Nr. Re. Nr. Ref. Nr. Код №	Marca della macchina Machine brand name Marke der Maschine Marque de la machine Марка машины	Tipo e codice originale Type and original code Typ original hersteller Type et code d'origine Тип и оригинальный код	Codice Nr. Ref. Nr. Re. Nr. Ref. Nr. Код №
--	--	--	--	--	--

RICAMBIO NON ORIGINALE PER KVERNELAND		252102	RICAMBIO NON ORIGINALE PER KVERNELAND		252501
		gr 430			gr 280
	RF23451	90×4			85,5×4

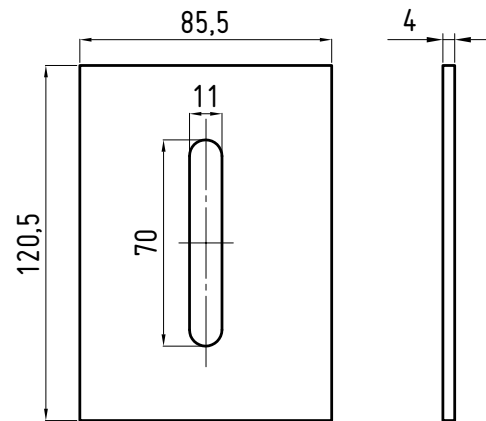
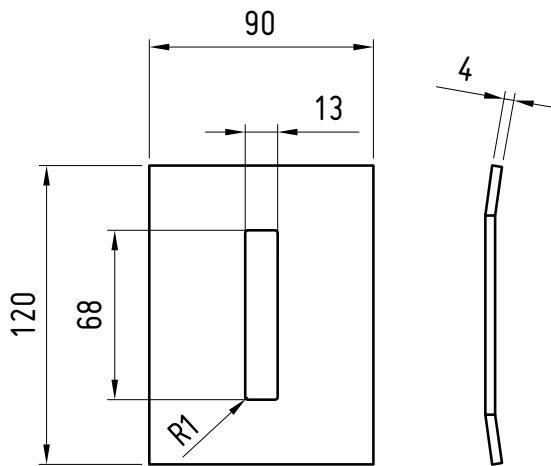

RICAMBIO NON ORIGINALE PER LANDSBERG		245501	RICAMBIO NON ORIGINALE PER LANDSBERG		245502
		gr 220			gr 430
		80×3		435780	75×5

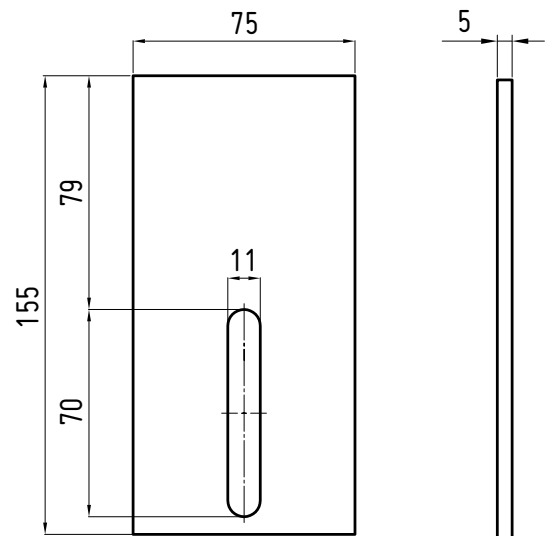
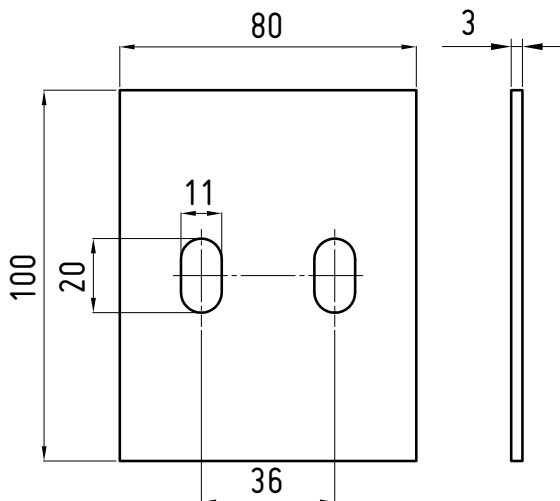

RASCHIETTI
Scraper
Schaber
Grattoirs
Скребки



Marca della macchina Machine brand name Marke der Maschine Marque de la machine Марка машины	Tipo e codice originale Type and original code Typ original hersteller Type et code d'origine Тип и оригинальный код	Codice Nr. Ref. Nr. Re. Nr. Ref. Nr. Код №	Marca della macchina Machine brand name Marke der Maschine Marque de la machine Марка машины	Tipo e codice originale Type and original code Typ original hersteller Type et code d'origine Тип и оригинальный код	Codice Nr. Ref. Nr. Re. Nr. Ref. Nr. Код №
RICAMBIO NON ORIGINALE PER LANDSBERG		245503	RICAMBIO NON ORIGINALE PER LELY		0119
	060800	gr 140		0119	gr 210
		50×3			90×3

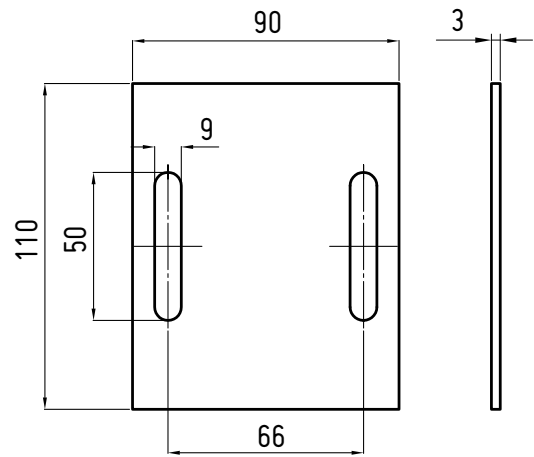
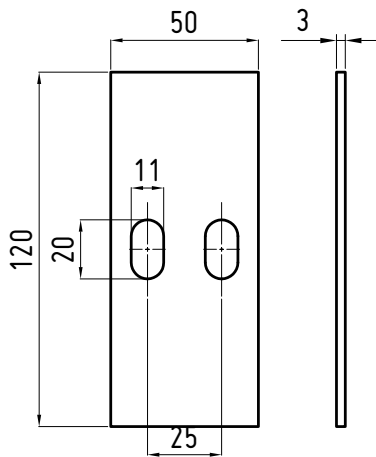

RICAMBIO NON ORIGINALE PER LELY		435011	RICAMBIO NON ORIGINALE PER LELY		435012
	1.1632.2304.0	gr 300		1.1645.2944.0	gr 250
		100×3			100×3

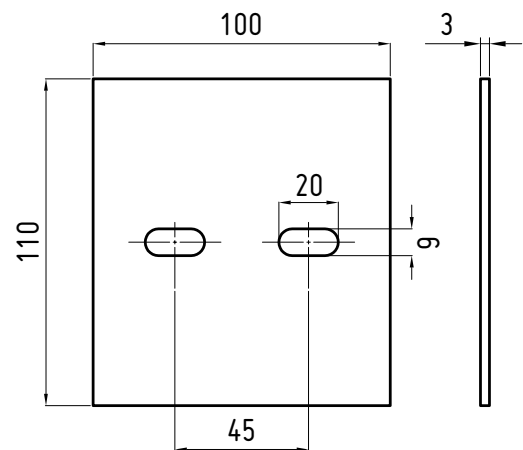
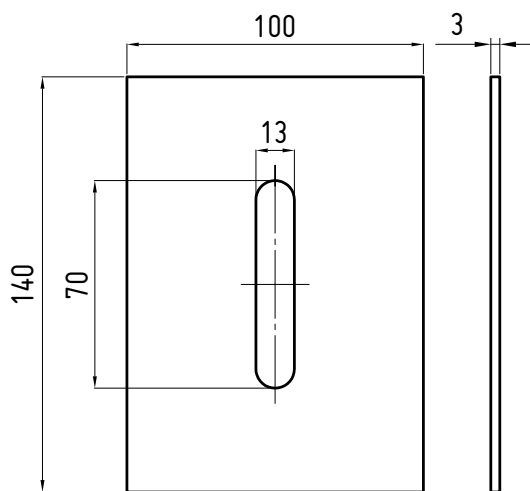

Tutti i modelli sono di nostra produzione e non originali.
 All models are of our manufacture and are not original.
 Alle unsere Landwirtschaftliche erzeugnisse sind unsere produktion und sind nicht original.
 Tous les modèles sont notre production et ne sont pas des produits d'origine.
 Все модели нашего производства и не являются оригинальными.

N.B. Pesi e misure sopra descritti sono puramente indicativi.
 N.B. The above weights and dimensions are given for reference only.
 N.B. Die obengenannten Gewichte und Abmessungen sind richtungsweisend.
 N.B. Les poids et les dimensions indiqués ci-dessus sont donnés à titre indicatif.
 N.B. Указанные вес и размеры, являются ориентировочными.

© La riproduzione
 anche parziale
 del presente catalogo
 è vietata.

RASCHIETTI
Scraper
Schaber
Grattoirs
Скребки



Marca della macchina
 Machine brand name
 Marke der Maschine
 Marque de la machine
 Марка машины

Tipo e codice originale
 Type and original code
 Typ original hersteller
 Type et code d'origine
 Тип и оригинальный код

Codice Nr.
 Ref. Nr.
 Re. Nr.
 Ref. Nr.
 Код №

Marca della macchina
 Machine brand name
 Marche desmaschine
 Marque de la machine
 Марка машины

Tipo e codice originale
 Type and original code
 Typ original hersteller
 Type et code d'origine
 Тип и оригинальный код

Codice Nr.
 Ref. Nr.
 Re. Nr.
 Ref. Nr.
 Код №

RICAMBIO NON ORIGINALE PER LELY		435502	RICAMBIO NON ORIGINALE PER LELY		435503
		gr 195			gr 220
	1.1645.2837.0	75×3		1.1645.2838.0	75×3

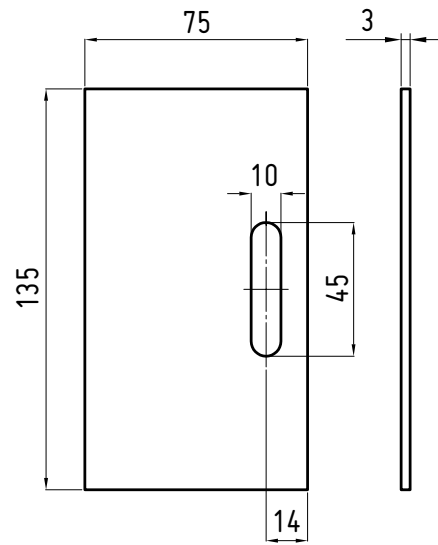
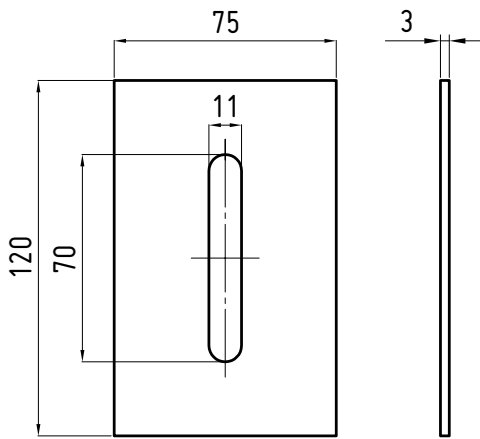

RICAMBIO NON ORIGINALE PER LELY		435504	RICAMBIO NON ORIGINALE PER LELY		435505
		gr 300			gr 160
	1.1606.4078.0	100×3		1.1606.3479.0	55×3

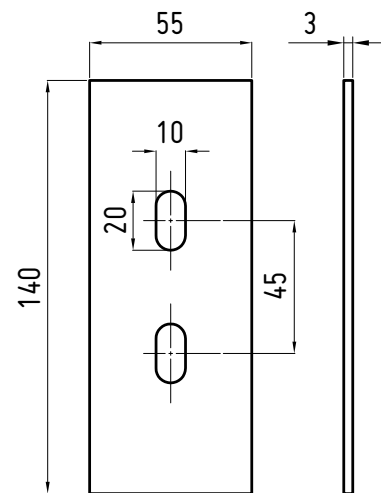
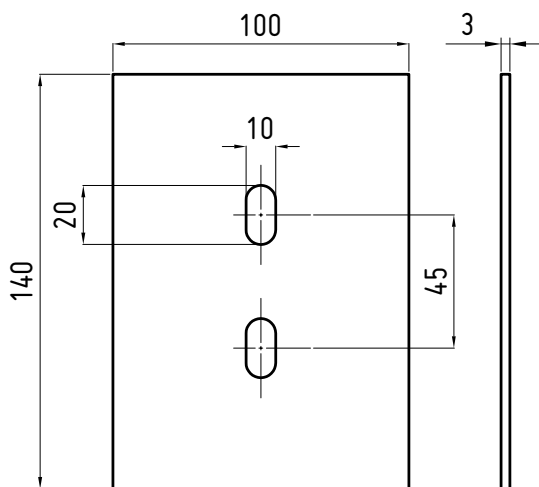

RASCHIETTI
Scraper
Schaber
Grattoirs
Скребки



Marca della macchina Machine brand name Marke der Maschine Marque de la machine Марка машины	Tipo e codice originale Type and original code Typ original hersteller Type et code d'origine Тип и оригинальный код	Codice Nr. Ref. Nr. Re. Nr. Ref. Nr. Код №	Marca della macchina Machine brand name Marke der Maschine Marque de la machine Марка машины	Tipo e codice originale Type and original code Typ original hersteller Type et code d'origine Тип и оригинальный код	Codice Nr. Ref. Nr. Re. Nr. Ref. Nr. Код №
RICAMBIO NON ORIGINALE PER LELY		435506	RICAMBIO NON ORIGINALE PER LELY		435507
	1201	gr 240 100×3		1.1680.1661.0	gr 170 60×3

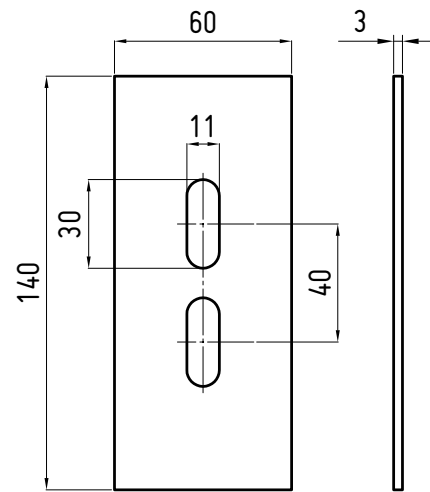
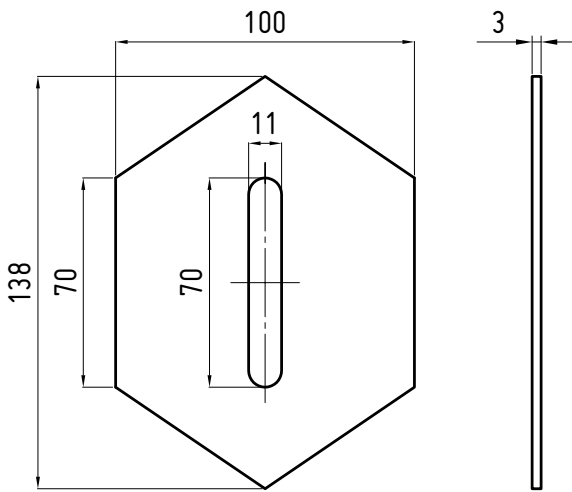

RICAMBIO NON ORIGINALE PER LELY		435508	RICAMBIO NON ORIGINALE PER LELY		435509
	1.1645.2948.0	gr 310 100×3		1.1645.9000.0	gr 220 100×3

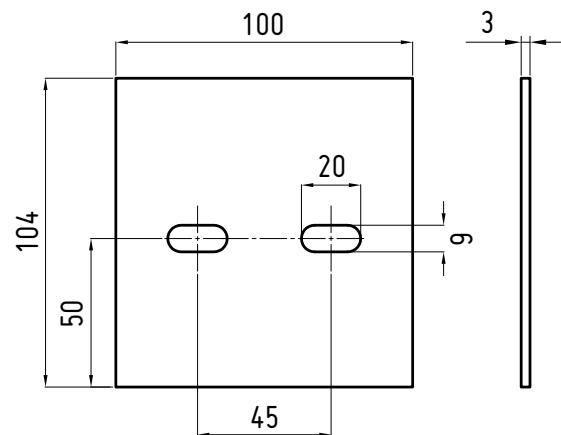
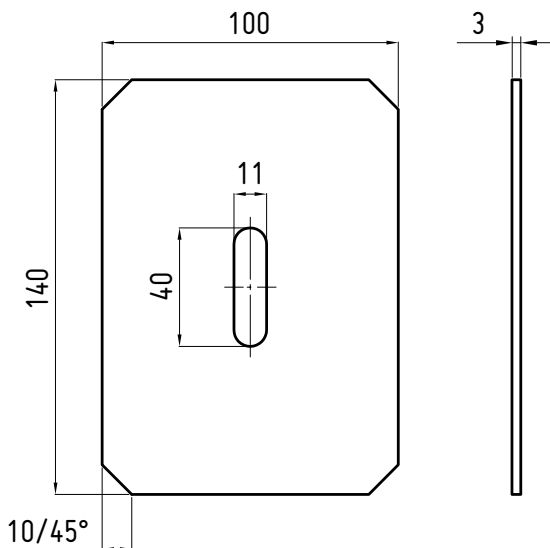

Tutti i modelli sono di nostra produzione e non originali.
 All models are of our manufacture and are not original.
 Alle unsere Landwirtschaftliche erzeugnisse sind unsere produktion und sind nicht original.
 Tous les modèles sont notre production et ne sont pas des produits d'origine.
 Все модели нашего производства и не являются оригинальными.

N.B. Pesi e misure sopra descritti sono puramente indicativi.
 N.B. The above weights and dimensions are given for reference only.
 N.B. Die obengenannten Gewichte und Abmessungen sind richtungsweisend.
 N.B. Les poids et les dimensions indiqués ci-dessus sont donnés à titre indicatif.
 N.B. Указанные вес и размеры, являются ориентировочными.

© La riproduzione
 anche parziale
 del presente catalogo
 è vietata.

RASCHIETTI
Scraper
Schaber
Grattoirs
Скребки



Marca della macchina
 Machine brand name
 Marke der Maschine
 Marque de la machine
 Марка машины

Tipo e codice originale
 Type and original code
 Typ original hersteller
 Type et code d'origine
 Тип и оригинальный код

Codice Nr.
 Ref. Nr.
 Re. Nr.
 Ref. Nr.
 Код №

Marca della macchina
 Machine brand name
 Marche des machine
 Marque de la machine
 Марка машины

Tipo e codice originale
 Type and original code
 Typ original hersteller
 Type et code d'origine
 Тип и оригинальный код

Codice Nr.
 Ref. Nr.
 Re. Nr.
 Ref. Nr.
 Код №

RICAMBIO NON ORIGINALE PER LELY	1.1645.9001.0	435510	RICAMBIO NON ORIGINALE PER LELY	1.1632.2304.1	435511
		gr 210			gr 300
		100x3			90x3

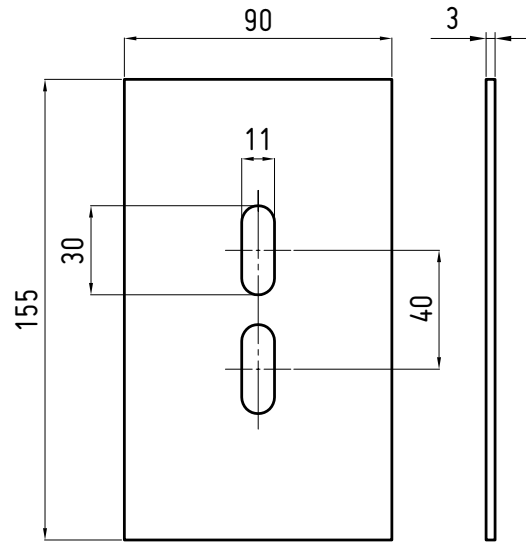
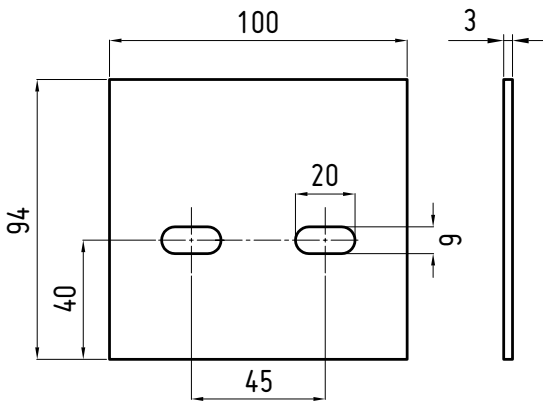

RICAMBIO NON ORIGINALE PER LELY	1.1645.2839.0	435513	RICAMBIO NON ORIGINALE PER LELY	3011	435514
		gr 270			gr 260
		100x3			100x3

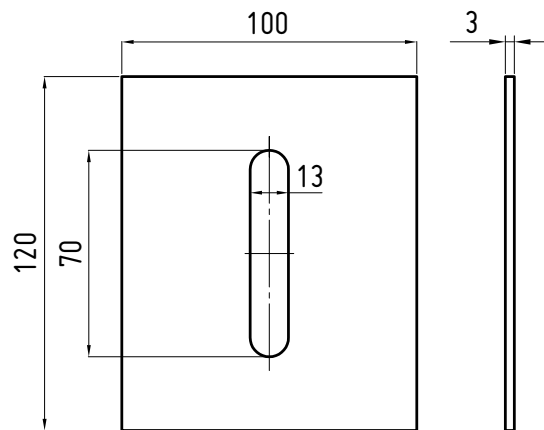
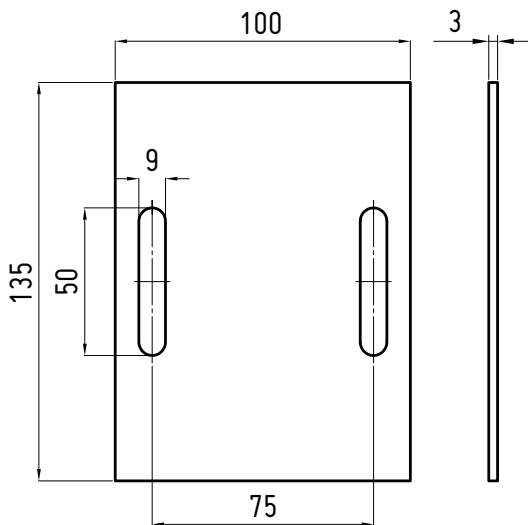

RASCHIETTI
Scraper
Schaber
Grattoirs
Скребки



Marca della macchina Machine brand name Marke der Maschine Marque de la machine Марка машины	Tipo e codice originale Type and original code Typ original hersteller Type et code d'origine Тип и оригинальный код	Codice Nr. Ref. Nr. Re. Nr. Ref. Nr. Код №	Marca della macchina Machine brand name Marke der Maschine Marque de la machine Марка машины	Tipo e codice originale Type and original code Typ original hersteller Type et code d'origine Тип и оригинальный код	Codice Nr. Ref. Nr. Re. Nr. Ref. Nr. Код №
RICAMBIO NON ORIGINALE PER LELY		435515	RICAMBIO NON ORIGINALE PER LELY		435516
		gr 160		1.1625.2242.0	gr 220
		60×3			75×3

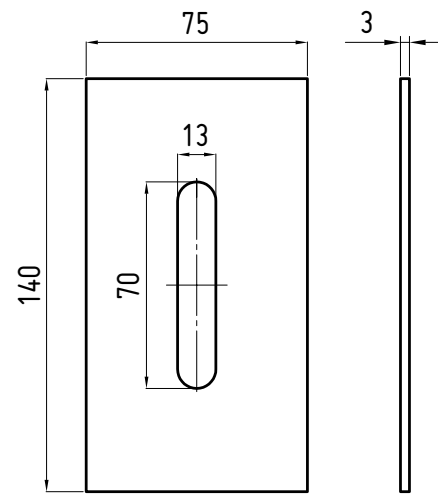
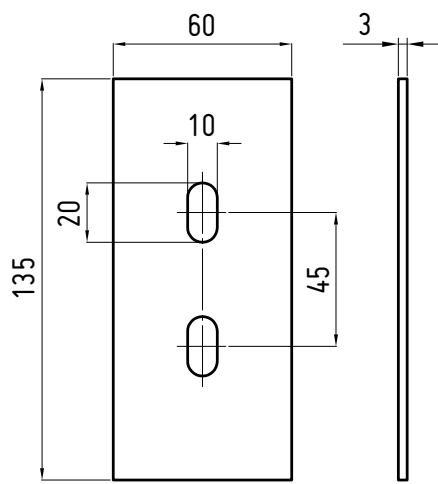

RICAMBIO NON ORIGINALE PER LEMKEN		436501	RICAMBIO NON ORIGINALE PER MASCHIO		255072
	3492001	gr 250		27100539	gr 200
		90×3			95×3

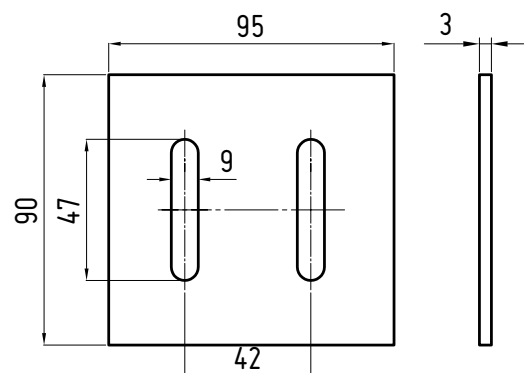
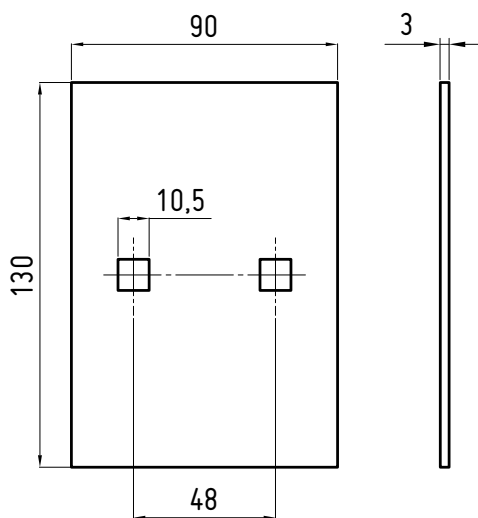

RASCHIETTI
Scraper
Schaber
Grattoirs
Скребки



Marca della macchina
 Machine brand name
 Marke der Maschine
 Marque de la machine
 Марка машины

Tipo e codice originale
 Type and original code
 Typ original hersteller
 Type original hersteller
 Type et code d'origine
 Тип и оригинальный код

Codice Nr.
 Ref. Nr.
 Re. Nr.
 Ref. Nr.
 Код №

Marca della macchina
 Machine brand name
 Marche des machine
 Marque de la machine
 Марка машины

Tipo e codice originale
 Type and original code
 Typ original hersteller
 Type original hersteller
 Type et code d'origine
 Тип и оригинальный код

Codice Nr.
 Ref. Nr.
 Re. Nr.
 Ref. Nr.
 Код №

RICAMBIO NON ORIGINALE PER MASCHIO		255501	RICAMBIO NON ORIGINALE PER MASCHIO		255502
		gr 265			gr 190
	h7041	97×3			95×3

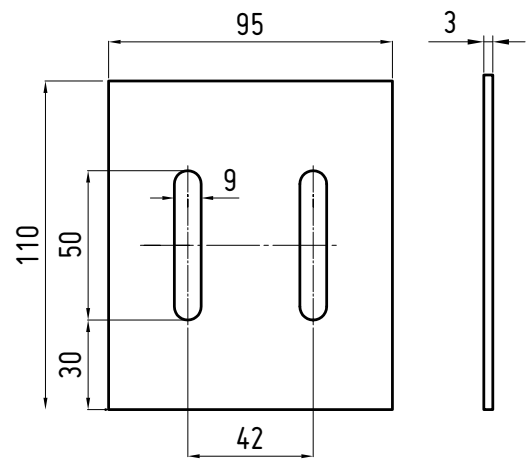
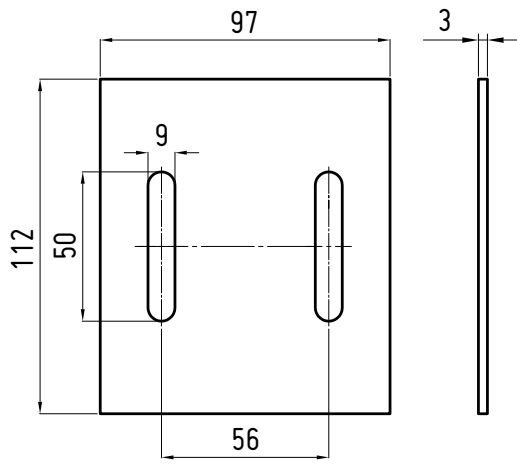

RICAMBIO NON ORIGINALE PER MASCHIO		804111	RICAMBIO NON ORIGINALE PER MORRA		271501
		gr 190			gr 260
		73×3			70×5

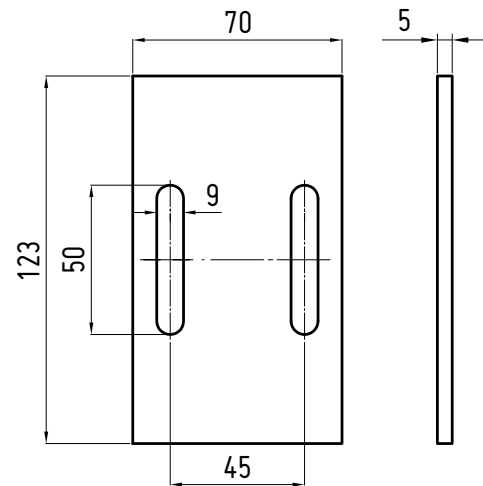
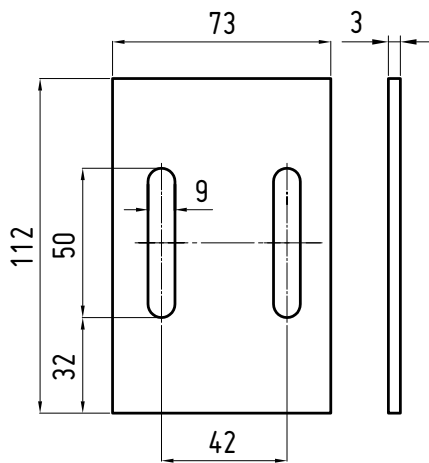

RASCHIETTI
Scraper
Schaber
Grattoirs
Скребки



Marca della macchina Machine brand name Marke der Maschine Marque de la machine Марка машины	Tipo e codice originale Type and original code Typ original hersteller Type et code d'origine Тип и оригинальный код	Codice Nr. Ref. Nr. Re. Nr. Ref. Nr. Код №	Marca della macchina Machine brand name Marke der Maschine Marque de la machine Марка машины	Tipo e codice originale Type and original code Typ original hersteller Type et code d'origine Тип и оригинальный код	Codice Nr. Ref. Nr. Re. Nr. Ref. Nr. Код №
MORRA		271502 gr 160 45×4	NIEMEYER	034102	373501 gr 350 70×5

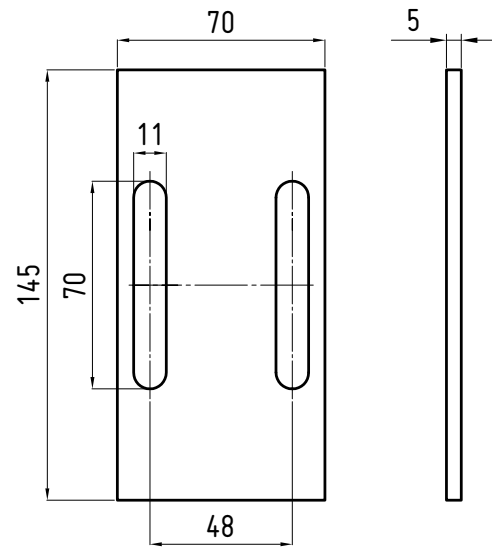
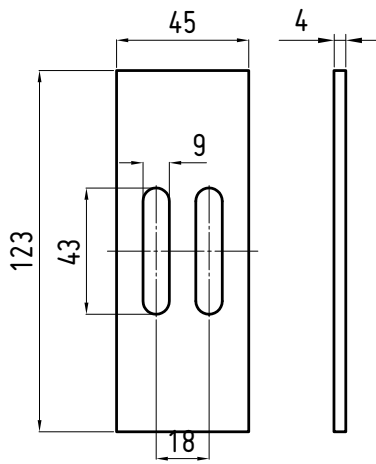

NIEMEYER		373502 gr 410 70×6	NIEMEYER	034575	373503 gr 530 86×6
-----------------	--	---------------------------------	-----------------	---------------	---------------------------------

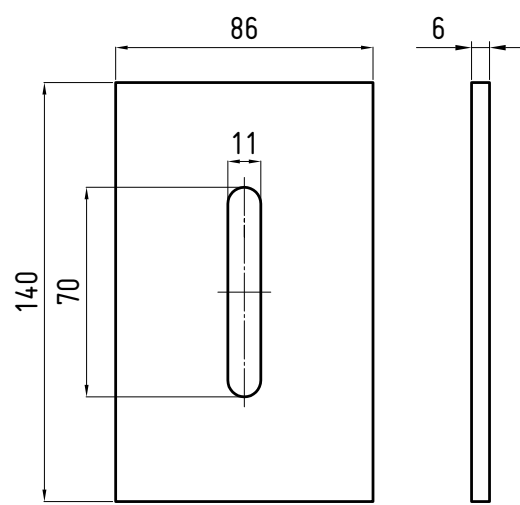
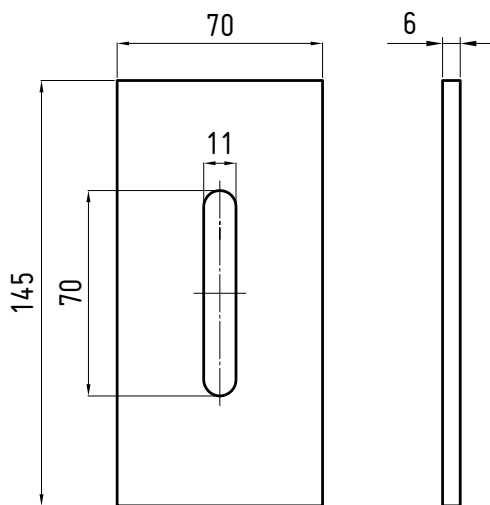

Tutti i modelli sono di nostra produzione e non originali.
 All models are of our manufacture and are not original.
 Alle unsere Landwirtschaftliche erzeugnisse sind unsere produktion und sind nicht original.
 Tous les modèles sont notre production et ne sont pas des produits d'origine.
 Все модели нашего производства и не являются оригинальными.

N.B. Pesi e misure sopra descritti sono puramente indicativi.
 N.B. The above weights and dimensions are given for reference only.
 N.B. Die obengenannten Gewichte und Abmessungen sind richtungsweisend.
 N.B. Les poids et les dimensions indiqués ci-dessus sont donnés à titre indicatif.
 N.B. Указанные вес и размеры, являются ориентировочными.

© La riproduzione
 anche parziale
 del presente catalogo
 è vietata.

RASCHIETTI
Scraper
Schaber
Grattoirs
Скребки



Marca della macchina
 Machine brand name
 Marke der Maschine
 Marque de la machine
 Марка машины

Tipo e codice originale
 Type and original code
 Typ original hersteller
 Type et code d'origine
 Тип и оригинальный код

Codice Nr.
 Ref. Nr.
 Re. Nr.
 Ref. Nr.
 Код №

Marca della macchina
 Machine brand name
 Marche des machine
 Marque de la machine
 Марка машины

Tipo e codice originale
 Type and original code
 Typ original hersteller
 Type et code d'origine
 Тип и оригинальный код

Codice Nr.
 Ref. Nr.
 Re. Nr.
 Ref. Nr.
 Код №

RICAMBIO NON ORIGINALE PER PEGORARO		302041	RICAMBIO NON ORIGINALE PER PEGORARO		302501
		gr 210			gr 440
	06567	80×3			90×5

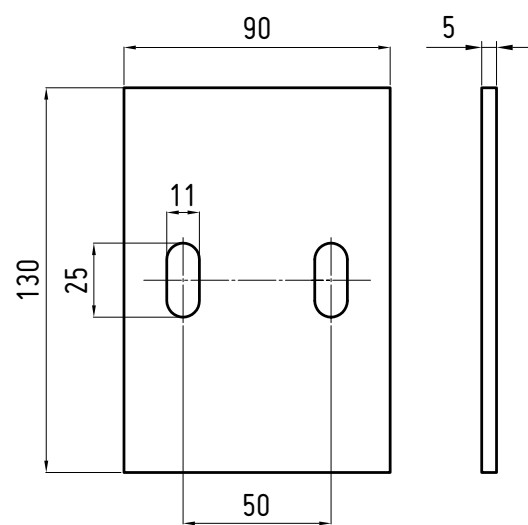
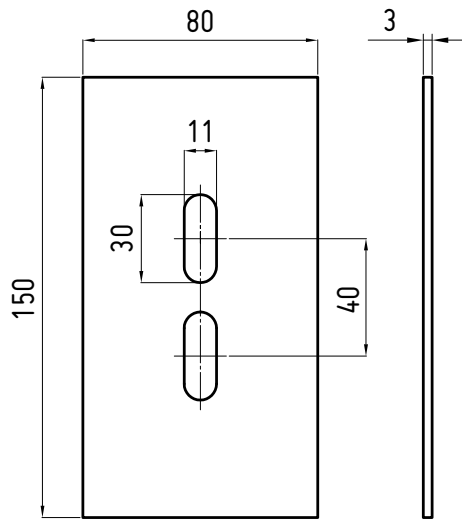

RICAMBIO NON ORIGINALE PER PERUGINI		304025	RICAMBIO NON ORIGINALE PER RABEWERK		448006
		gr 410			gr 390
		90×5			80×4

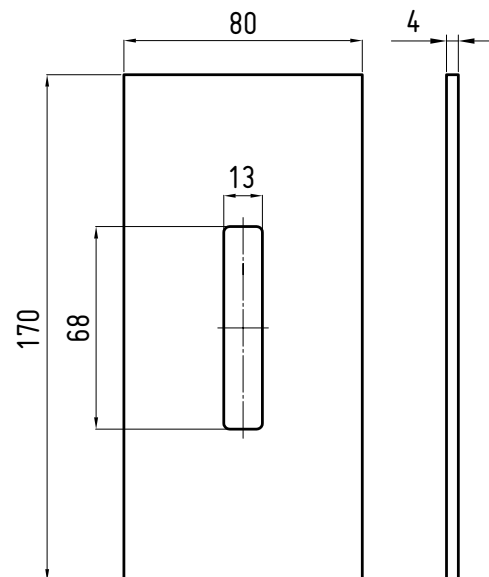
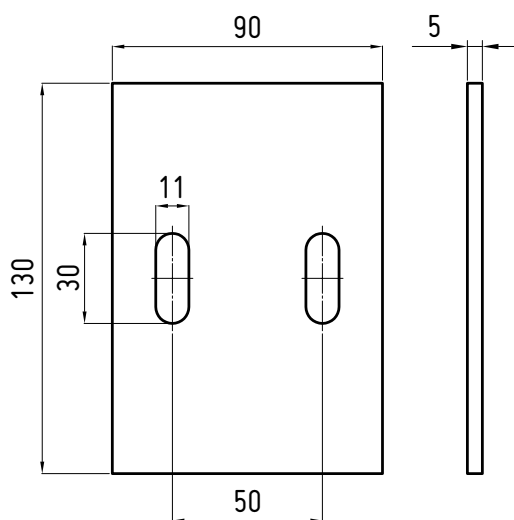

RASCHIETTI
Scraper
Schaber
Grattoirs
Скребки



Marca della macchina Machine brand name Marke der Maschine Marque de la machine Марка машины	Tipo e codice originale Type and original code Typ original hersteller Type et code d'origine Тип и оригинальный код	Codice Nr. Ref. Nr. Re. Nr. Ref. Nr. Код №	Marca della macchina Machine brand name Marche des machine Marque de la machine Марка машины	Tipo e codice originale Type and original code Typ original hersteller Type et code d'origine Тип и оригинальный код	Codice Nr. Ref. Nr. Re. Nr. Ref. Nr. Код №
--	--	--	--	--	--

RICAMBIO NON ORIGINALE PER RABEWERK	H7012	448501	RICAMBIO NON ORIGINALE PER RABEWERK	H7010	448502
	84050027	gr 380 80×4		84062501	gr 280 50×5

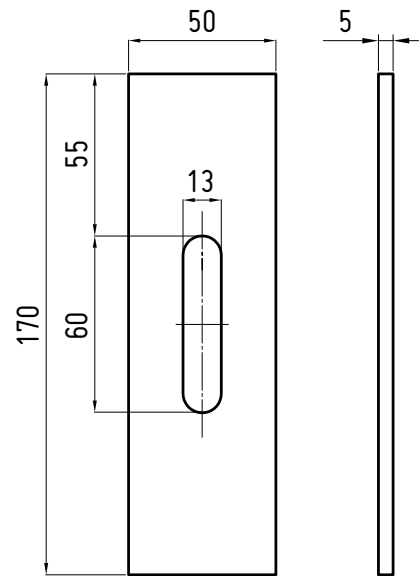
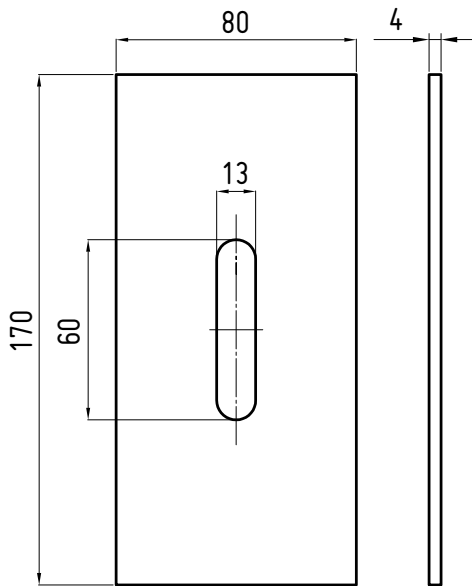

RICAMBIO NON ORIGINALE PER RABEWERK		448503	RICAMBIO NON ORIGINALE PER RABEWERK		448504
	84050027	gr 300 80×3			gr 170 50×3

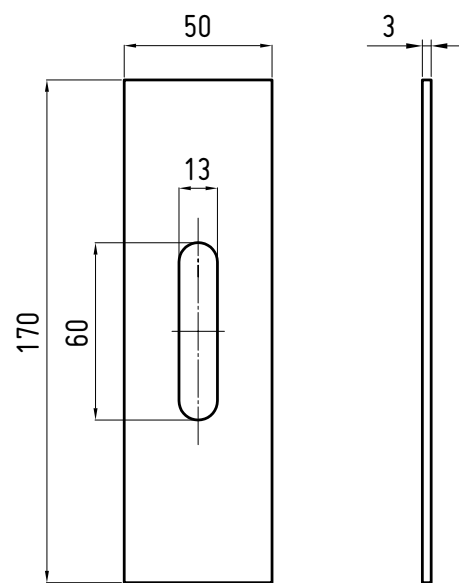
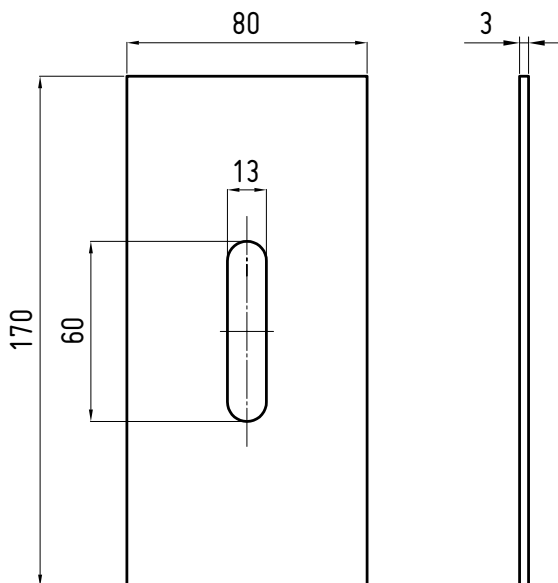

Tutti i modelli sono di nostra produzione e non originali.
 All models are of our manufacture and are not original.
 Alle unsere Landwirtschaftliche erzeugnisse sind unsere produktion und sind nicht original.
 Tous les modèles sont notre production et ne sont pas des produits d'origine.
 Все модели нашего производства и не являются оригинальными.

N.B. Pesi e misure sopra descritti sono puramente indicativi.
 N.B. The above weights and dimensions are given for reference only.
 N.B. Die obengenannten Gewichte und Abmessungen sind richtungsweisend.
 N.B. Les poids et les dimensions indiqués ci-dessus sont donnés à titre indicatif.
 N.B. Указанные вес и размеры, являются ориентировочными.

© La riproduzione anche parziale del presente catalogo è vietata.

RASCHIETTI
Scraper
Schaber
Grattoirs
Скребки



Marca della macchina
 Machine brand name
 Marke der Maschine
 Marque de la machine
 Марка машины

Tipo e codice originale
 Type and original code
 Typ original hersteller
 Type et code d'origine
 Тип и оригинальный код

Codice Nr.
 Ref. Nr.
 Re. Nr.
 Ref. Nr.
 Код №

Marca della macchina
 Machine brand name
 Marche des machine
 Marque de la machine
 Марка машины

Tipo e codice originale
 Type and original code
 Typ original hersteller
 Type et code d'origine
 Тип и оригинальный код

Codice Nr.
 Ref. Nr.
 Re. Nr.
 Ref. Nr.
 Код №

RICAMBIO NON ORIGINALE PER RABEWERK	H7013	448505	RICAMBIO NON ORIGINALE PER RABEWERK		448506
	84050027	gr 500			gr 250
		80×5			70×3

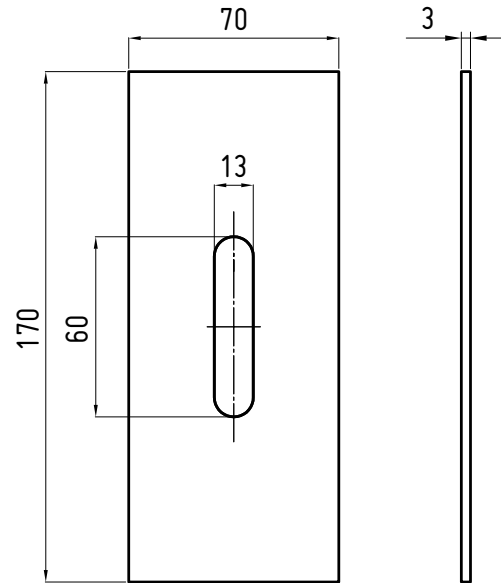
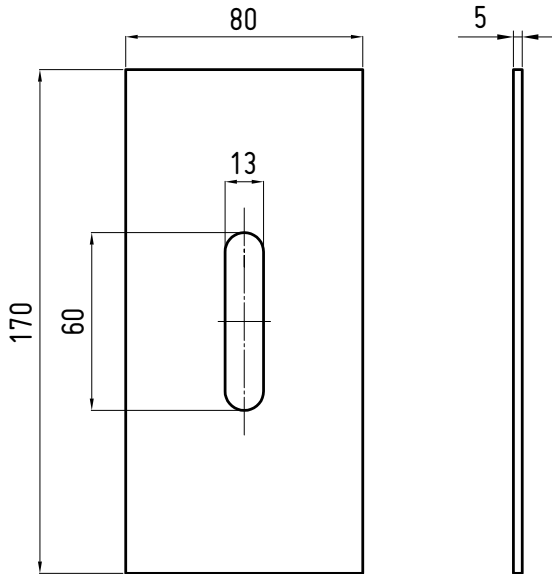

RICAMBIO NON ORIGINALE PER RASCHIETTO UNIVERSALE		RAS 01	RICAMBIO NON ORIGINALE PER RASCHIETTO UNIVERSALE		RAS 03
		gr 445			gr 300
		75×4			90×5

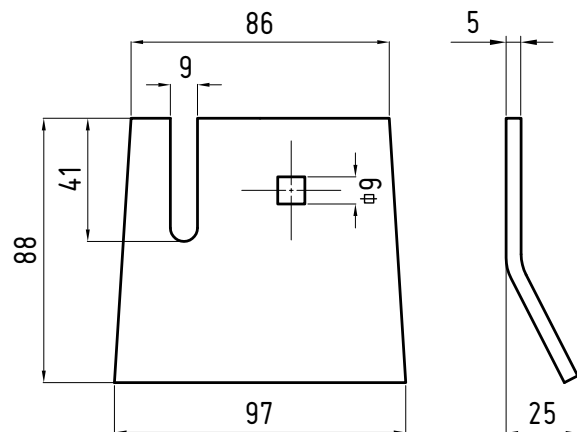
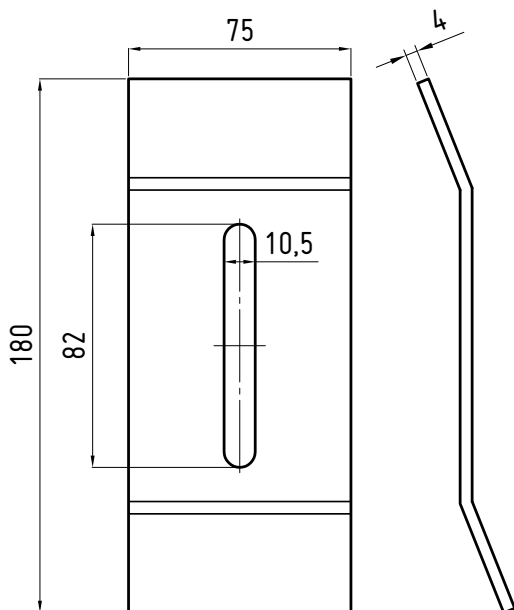

RASCHIETTI
Scraper
Schaber
Grattoirs
Скребки



Marca della macchina
 Machine brand name
 Marke der Maschine
 Marque de la machine
 Марка машины

Tipo e codice originale
 Type and original code
 Typ original hersteller
 Type et code d'origine
 Тип и оригинальный код

Codice Nr.
 Ref. Nr.
 Re. Nr.
 Ref. Nr.
 Код №

Marca della macchina
 Machine brand name
 Marche des machine
 Marque de la machine
 Марка машины

Tipo e codice originale
 Type and original code
 Typ original hersteller
 Type et code d'origine
 Тип и оригинальный код

Codice Nr.
 Ref. Nr.
 Re. Nr.
 Ref. Nr.
 Код №

RICAMBIO NON ORIGINALE PER

RASCHIETTO
UNIVERSALE

RAS 07

gr 1800

150x6

RICAMBIO NON ORIGINALE PER

RAU

SK 2073

48230-91026

449501

gr 340

90x4

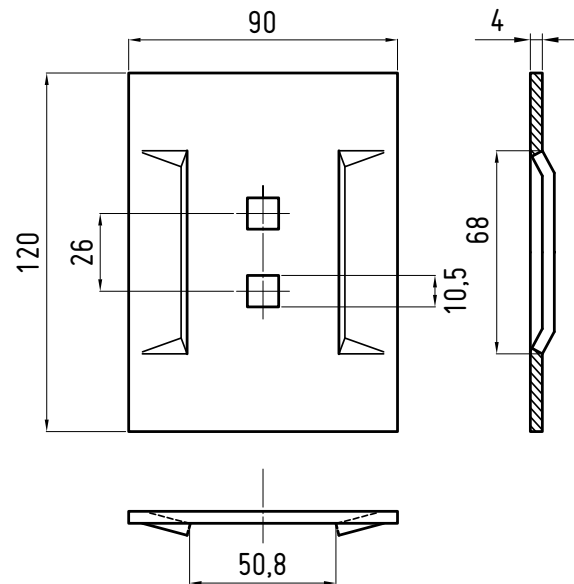
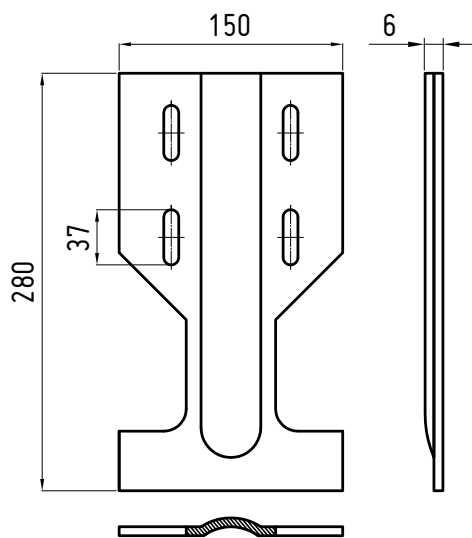

RICAMBIO NON ORIGINALE PER

RAU

29743-91025

449502

gr 270

70x4

RICAMBIO NON ORIGINALE PER

SICMA

332501

gr 142

50x3

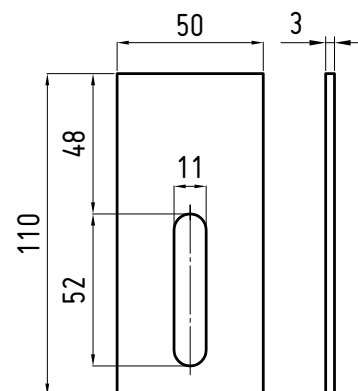
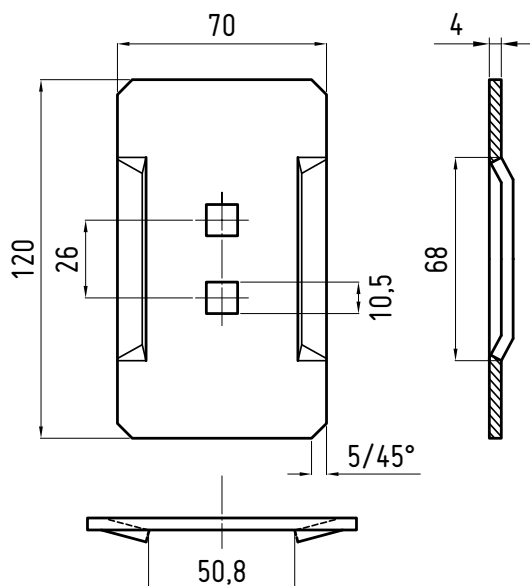

Tutti i modelli sono di nostra produzione e non originali.
 All models are of our manufacture and are not original.
 Alle unsere Landwirtschaftliche erzeugnisse sind unsere produktion und sind nicht original.
 Tous les modèles sont notre production et ne sont pas des produits d'origine.
 Все модели нашего производства и не являются оригинальными.

N.B. Pesi e misure sopra descritti sono puramente indicativi.
 N.B. The above weights and dimensions are given for reference only.
 N.B. Die obengenannten Gewichte und Abmessungen sind richtungsweisend.
 N.B. Les poids et les dimensions indiqués ci-dessus sont donnés à titre indicatif.
 N.B. Указанные вес и размеры, являются ориентировочными.

© La riproduzione
 anche parziale
 del presente catalogo
 è vietata.

RASCHIETTI
Scraper
Schaber
Grattoirs
Скребки



Marca della macchina
 Machine brand name
 Marke der Maschine
 Marque de la machine
 Марка машины

Tipo e codice originale
 Type and original code
 Typ original hersteller
 Type et code d'origine
 Тип и оригинальный код

Codice Nr.
 Ref. Nr.
 Re. Nr.
 Ref. Nr.
 Код №

Marca della macchina
 Machine brand name
 Marche des machine
 Marque de la machine
 Марка машины

Tipo e codice originale
 Type and original code
 Typ original hersteller
 Type et code d'origine
 Тип и оригинальный код

Codice Nr.
 Ref. Nr.
 Re. Nr.
 Ref. Nr.
 Код №

RICAMBIO NON ORIGINALE PER
SICMA

332502
 gr 142
 50×3

RICAMBIO NON ORIGINALE PER
SICMA

332503
 gr 215
 90×3

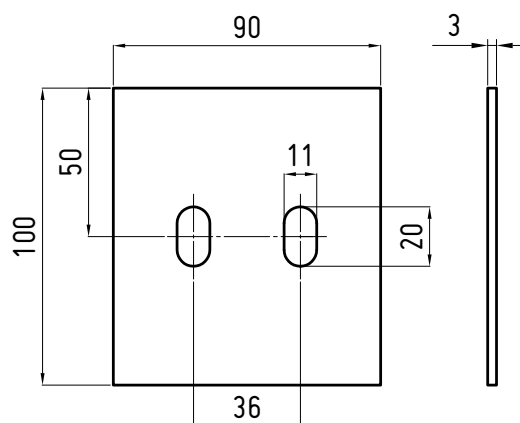
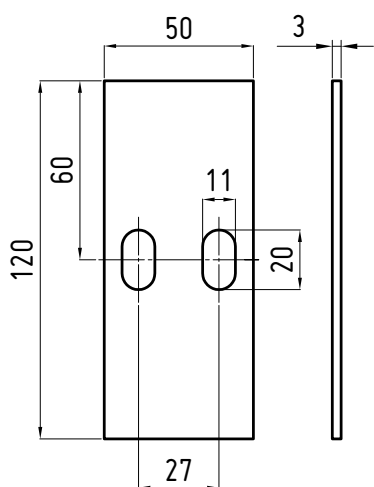

RICAMBIO NON ORIGINALE PER
SICMA

5818011052

332504
 gr 110
 50×3

RICAMBIO NON ORIGINALE PER
VIGOLO

931090001

360016
 gr 310
 95×4

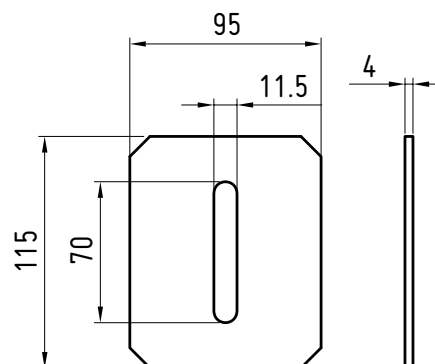
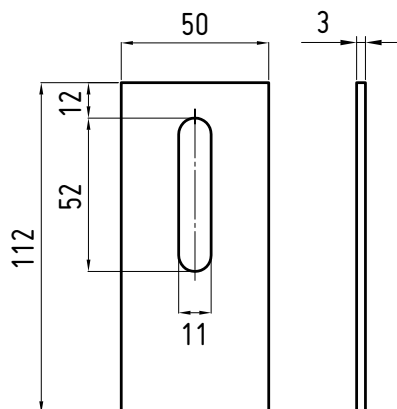



eurozappa

LAME PER TOSATRICI DA PRATO

Cutter blade

Randstreifenmesser

Couteaux de gyrobroyeur

Ножи для газонокосилок





LAME PER TOSATRICI DA PRATO
Cutter blade
Randstreifenmesser
Couteaux de gyrobroyeur
Ножи для газнокосилок



Marca della macchina Machine brand name Marke der Maschine Marque de la machine Марка машины	Tipo e codice originale Type and original code Typ original hersteller Type et code d'origine Тип и оригинальный код	Codice Nr. Ref. Nr. Re. Nr. Ref. Nr. Код №	Marca della macchina Machine brand name Marke der Maschine Marque de la machine Марка машины	Tipo e codice originale Type and original code Typ original hersteller Type et code d'origine Тип и оригинальный код	Codice Nr. Ref. Nr. Re. Nr. Ref. Nr. Код №
--	--	--	--	--	--

RICAMBIO NON ORIGINALE PER CARONI	LAMA RASAERBA	614001	RICAMBIO NON ORIGINALE PER CARONI	LAMA RASAERBA	614002
		50x6			60x6
		A = 520			A = 618

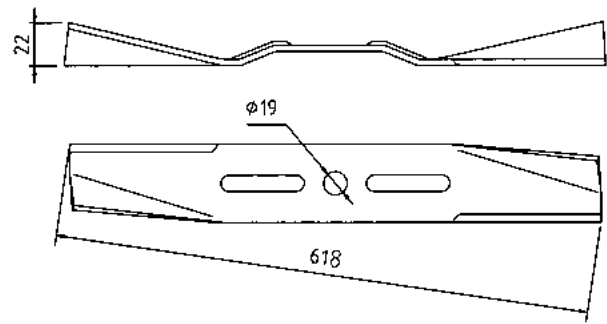
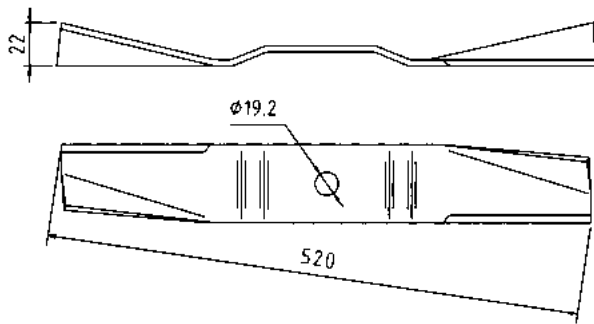

RICAMBIO NON ORIGINALE PER CARONI	LAMA RASAERBA	614003	RICAMBIO NON ORIGINALE PER CARONI	LAMA CON CHIAVETTA	614007
		50x6			50x5
		A = 425			A = 420

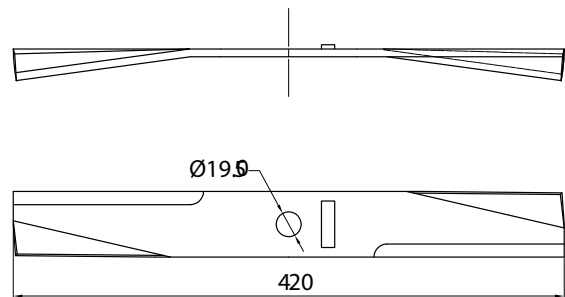
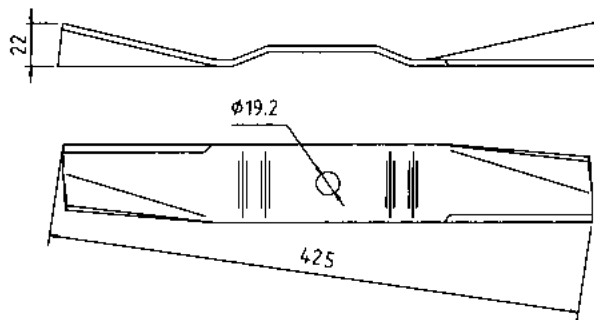

Tutti i modelli sono di nostra produzione e non originali.
 All models are of our manufacture and are not original.
 Alle unsere Landwirtschaftliche erzeugnisse sind unsere produktion und sind nicht original.
 Tous les modèles sont notre production et ne sont pas des produits d'origine.
 Все модели нашего производства и не являются оригинальными.

N.B. Pesi e misure sopra descritti sono puramente indicativi.
 N.B. The above weights and dimensions are given for reference only.
 N.B. Die obengenannten Gewichte und Abmessungen sind richtungsweisend.
 N.B. Les poids et les dimensions indiqués ci-dessus sont donnés à titre indicatif.
 N.B. Указанные вес и размеры, являются ориентировочными.

© La riproduzione
 anche parziale
 del presente catalogo
 è vietata.

LAME PER TOSATRICI DA PRATO

Cutter blade

Randstreifenmesser

Couteaux de gyrobroyeur

Ножи для газнокосилок



Marca della macchina Machine brand name Marke der Maschine Marque de la machine Марка машины	Tipo e codice originale Type and original code Typ original hersteller Type et code d'origine Тип и оригинальный код	Codice Nr. Ref. Nr. Re. Nr. Ref. Nr. Код №	Marca della macchina Machine brand name Marke der Maschine Marque de la machine Марка машины	Tipo e codice originale Type and original code Typ original hersteller Type et code d'origine Тип и оригинальный код	Codice Nr. Ref. Nr. Re. Nr. Ref. Nr. Код №
--	--	--	--	--	--

RICAMBIO NON ORIGINALE PER CARONI	LAMA CON CHIAVETTA	614008	RICAMBIO NON ORIGINALE PER CARONI	LAMA CON CHIAVETTA	614010
		50x5			50x5
		A = 350			A = 260

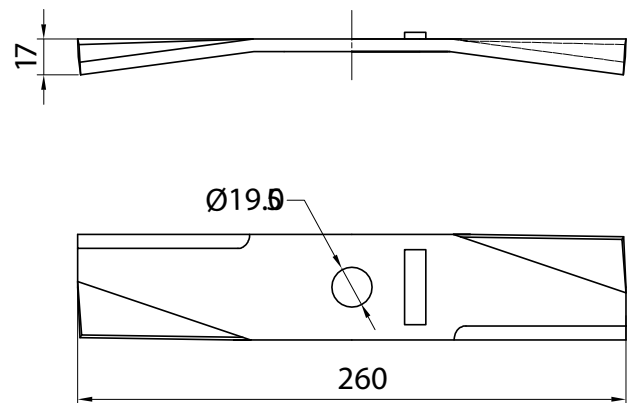
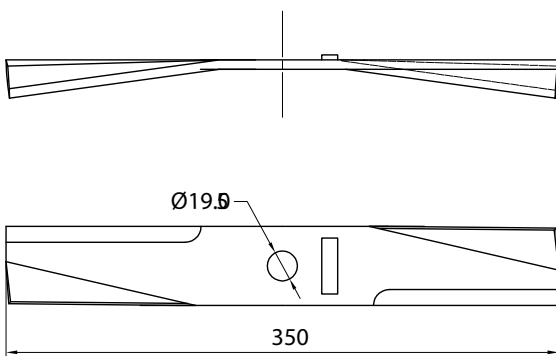

RICAMBIO NON ORIGINALE PER DEL MORINO	COLTELLO RASAERBA	165002	RICAMBIO NON ORIGINALE PER DEL MORINO	COLTELLO RASAERBA	165005
		75x12			80x12
		A = 490			A = 750

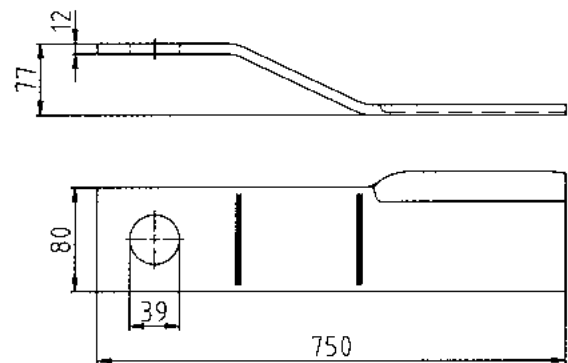
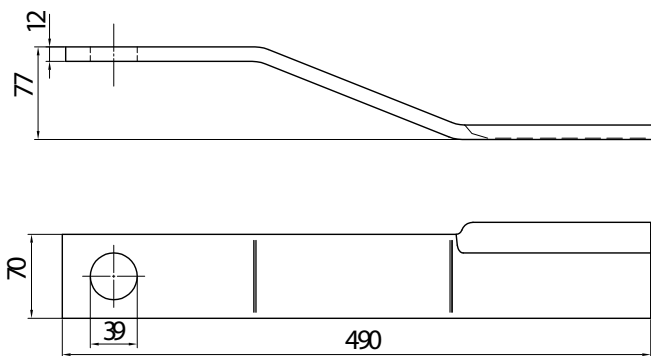

LAME PER TOSATRICI DA PRATO

Cutter blade

Randstreifenmesser

Couteaux de gyrobroyeur

Ножи для газнокосилок



Marca della macchina
Machine brand name
Marke der Maschine
Marque de la machine
Марка машины

Tipo e codice originale
Type and original code
Typ original hersteller
Type et code d'origine
Тип и оригинальный код

Codice Nr.
Ref. Nr.
Re. Nr.
Ref. Nr.
Код №

Marca della macchina
Machine brand name
Marke der Maschine
Marque de la machine
Марка машины

Tipo e codice originale
Type and original code
Typ original hersteller
Type et code d'origine
Тип и оригинальный код

Codice Nr.
Ref. Nr.
Re. Nr.
Ref. Nr.
Код №

RICAMBIO NON ORIGINALE PER
HOWARD

COLTELLO RASAERBA

225027

75x12

A = 320

RICAMBIO NON ORIGINALE PER
HOWARD

COLTELLO RASAERBA

225028

75x12

A = 390

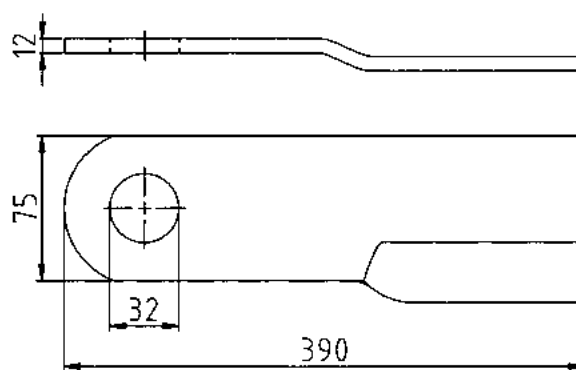
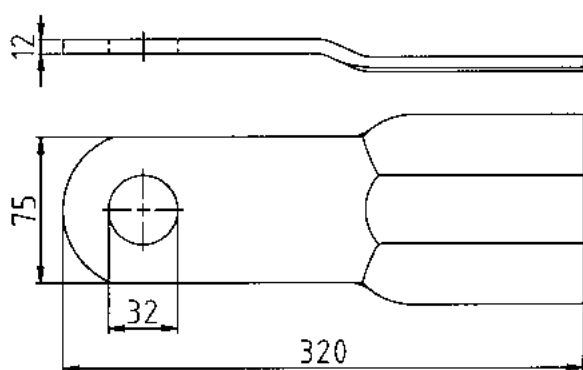

RICAMBIO NON ORIGINALE PER
HOWARD

COLTELLO RASAERBA

225029

75x10

A = 530

RICAMBIO NON ORIGINALE PER
HOWARD

COLTELLO RASAERBA

225037

75x12

A = 470

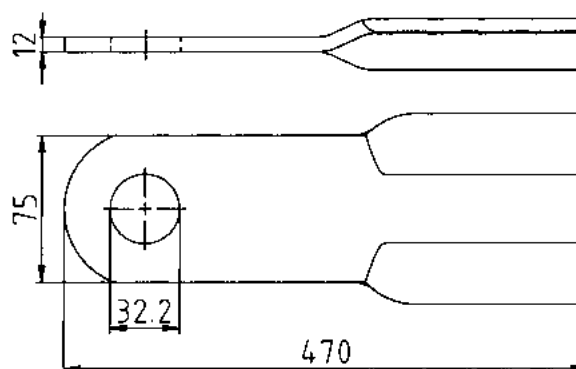
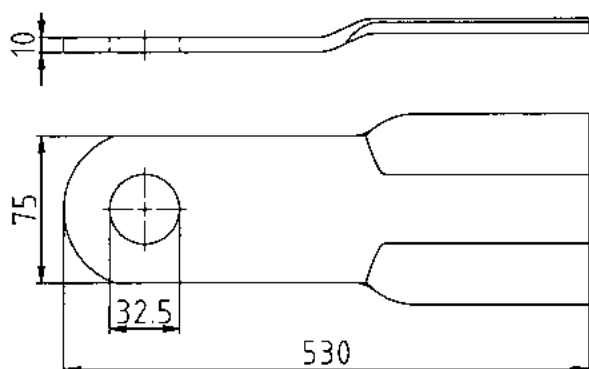

Tutti i modelli sono di nostra produzione e non originali.
All models are of our manufacture and are not original.
Alle unsere Landwirtschaftliche erzeugnisse sind unsere produktion und sind nicht original.
Tous les modèles sont notre production et ne sont pas des produits d'origine.
Все модели нашего производства и не являются оригинальными.

N.B. Pesi e misure sopra descritti sono puramente indicativi.
N.B. The above weights and dimensions are given for reference only.
N.B. Die obengenannten Gewichte und Abmessungen sind richtungsweisend.
N.B. Les poids et les dimensions indiqués ci-dessus sont donnés à titre indicatif.
N.B. Указанные вес и размеры, являются ориентировочными.

© La riproduzione
anche parziale
del presente catalogo
è vietata.

LAME PER TOSATRICI DA PRATO

Cutter blade

Randstreifenmesser

Couteaux de gyrobroyeur

Ножи для газнокосилок



Marca della macchina Machine brand name Marke der Maschine Marque de la machine Марка машины	Tipo e codice originale Type and original code Typ original hersteller Type et code d'origine Тип и оригинальный код	Codice Nr. Ref. Nr. Re. Nr. Ref. Nr. Код №	Marca della macchina Machine brand name Marche des machine Marque de la machine Марка машины	Tipo e codice originale Type and original code Typ original hersteller Type et code d'origine Тип и оригинальный код	Codice Nr. Ref. Nr. Re. Nr. Ref. Nr. Код №
--	--	--	--	--	--

RICAMBIO NON ORIGINALE PER HYMACH	COLTELLO 029A	150006	RICAMBIO NON ORIGINALE PER HYMACH	COLTELLO 029B	150007
		80x12			80x12
		A = 265			A = 345

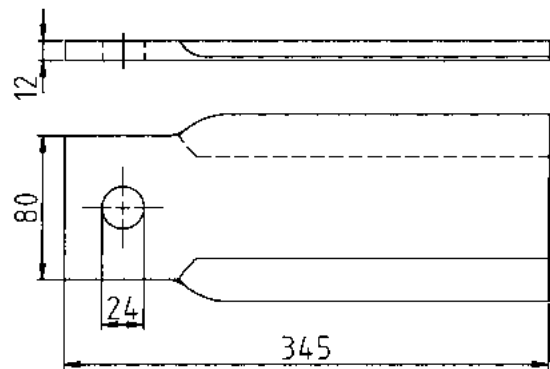
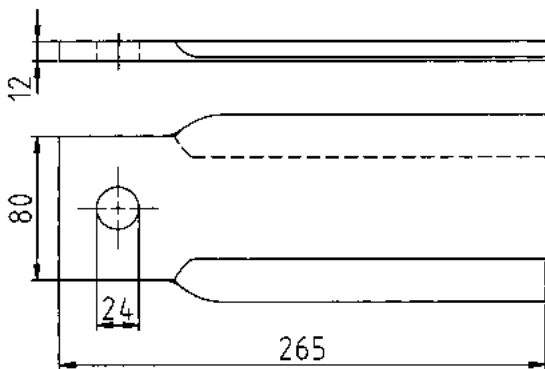

RICAMBIO NON ORIGINALE PER HYMACH	COLTELLO RBH25	150009	RICAMBIO NON ORIGINALE PER HYMACH	COLTELLO RBH25A	150009M1
		60x6			60x6
		A = 560			A = 450

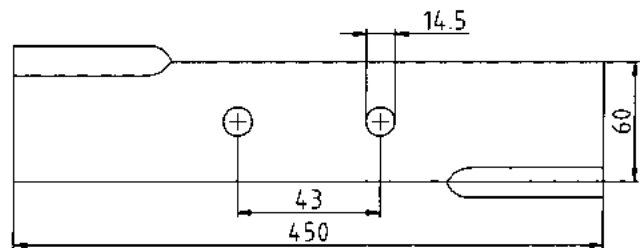
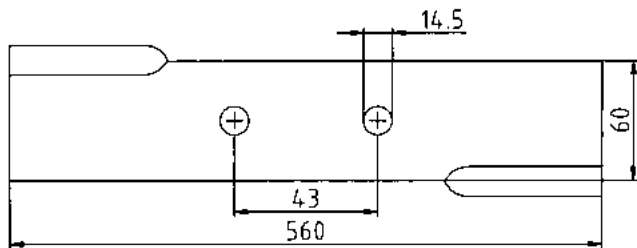

LAME PER TOSATRICI DA PRATO

Cutter blade

Randstreifenmesser

Couteaux de gyrobroyeur

Ножи для газнокосилок



Marca della macchina
Machine brand name
Marke der Maschine
Marque de la machine
Марка машины

Tipo e codice originale
Type and original code
Typ original hersteller
Type et code d'origine
Тип и оригинальный код

Codice Nr.
Ref. Nr.
Re. Nr.
Ref. Nr.
Код №

Marca della macchina
Machine brand name
Marke der Maschine
Marque de la machine
Марка машины

Tipo e codice originale
Type and original code
Typ original hersteller
Type et code d'origine
Тип и оригинальный код

Codice Nr.
Ref. Nr.
Re. Nr.
Ref. Nr.
Код №

RICAMBIO NON ORIGINALE PER
MASCHIO

LAMA RASAERBA

629001

T14004010

50×6

A = 515

RICAMBIO NON ORIGINALE PER
MASCHIO

LAMA RASAERBA

629002

T14004020

60×6

A = 613

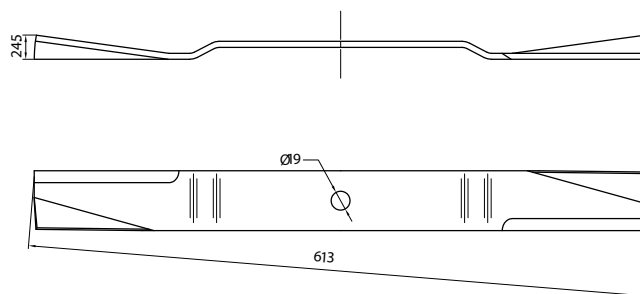
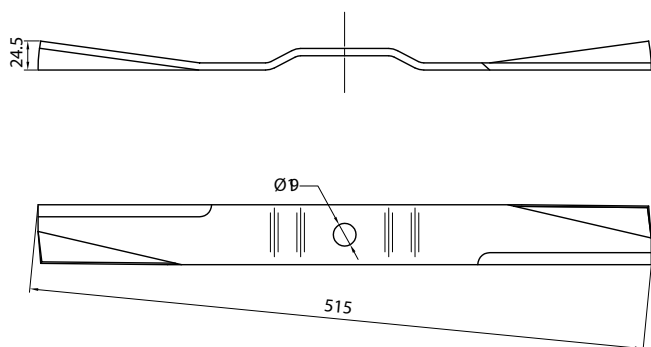

RICAMBIO NON ORIGINALE PER
MASCHIO

LAMA RASAERBA

629003

T14004030

50×6

A = 423

RICAMBIO NON ORIGINALE PER
MURATORI

LAMA RASAERBA

630001

50×6

A = 413

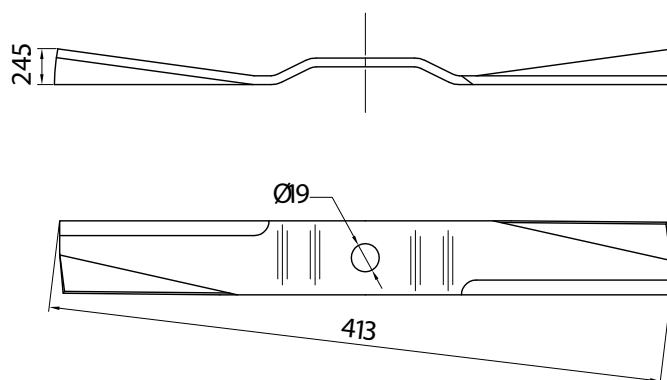
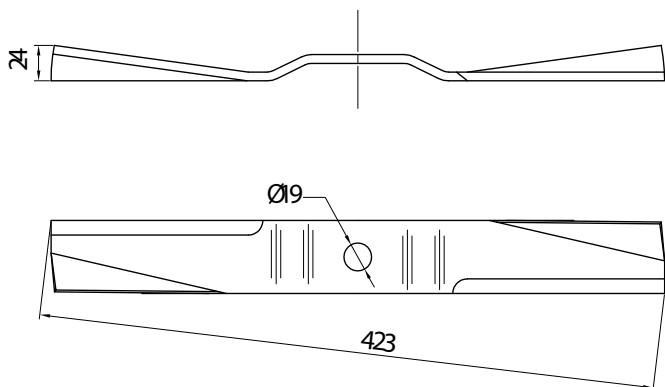

Tutti i modelli sono di nostra produzione e non originali.
All models are of our manufacture and are not original.
Alle unsere Landwirtschaftliche erzeugnisse sind unsere produktion und sind nicht original.
Tous les modèles sont notre production et ne sont pas des produits d'origine.
Все модели нашего производства и не являются оригинальными.

N.B. Pesi e misure sopra descritti sono puramente indicativi.
N.B. The above weights and dimensions are given for reference only.
N.B. Die obengenannten Gewichte und Abmessungen sind richtungsweisend.
N.B. Les poids et les dimensions indiqués ci-dessus sont donnés à titre indicatif.
N.B. Указанные вес и размеры, являются ориентировочными.

© La riproduzione
anche parziale
del presente catalogo
è vietata.

LAME PER TOSATRICI DA PRATO

Cutter blade

Randstreifenmesser

Couteaux de gyrobroyeur

Ножи для газонокосилок



Marca della macchina
Machine brand name
Marke der Maschine
Marque de la machine
Марка машины

Tipo e codice originale
Type and original code
Typ original hersteller
Type et code d'origine
Тип и оригинальный код

Codice Nr.
Ref. Nr.
Re. Nr.
Ref. Nr.
Код №

Marca della macchina
Machine brand name
Marke der Maschine
Marque de la machine
Марка машины

Tipo e codice originale
Type and original code
Typ original hersteller
Type et code d'origine
Тип и оригинальный код

Codice Nr.
Ref. Nr.
Re. Nr.
Ref. Nr.
Код №

RICAMBIO NON ORIGINALE PER
MURATORI

LAMA RASAERBA

630006

50×6

A = 514

RICAMBIO NON ORIGINALE PER
MURATORI

LAMA RASAERBA

630007

60×6

A = 615

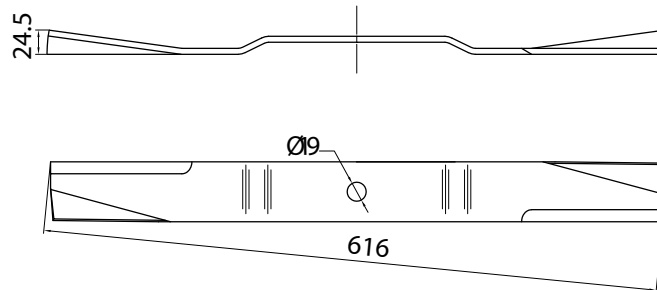
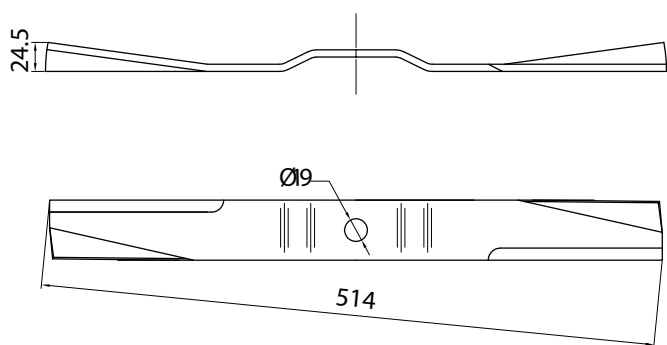

RICAMBIO NON ORIGINALE PER
TECMA

LAMA RASAERBA

642001

50×6

A = 514

RICAMBIO NON ORIGINALE PER
TECMA

LAMA RASAERBA

642002

60×6

A = 616

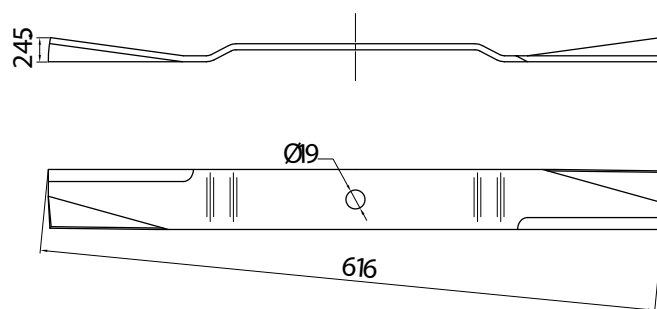
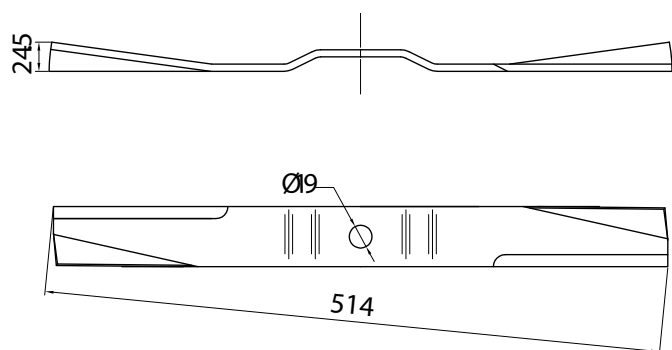

LAME PER TOSATRICI DA PRATO
Cutter blade
Randstreifenmesser
Couteaux de gyrobroyeur
Ножи для газонокосилок



Marca della macchina Machine brand name Marke der Maschine Marque de la machine Марка машины	Tipo e codice originale Type and original code Typ original hersteller Type et code d'origine Тип и оригинальный код	Codice Nr. Ref. Nr. Re. Nr. Ref. Nr. Код №	Marca della macchina Machine brand name Marche des machine Marque de la machine Марка машины	Tipo e codice originale Type and original code Typ original hersteller Type et code d'origine Тип и оригинальный код	Codice Nr. Ref. Nr. Re. Nr. Ref. Nr. Код №
--	--	--	--	--	--

RICAMBIO NON ORIGINALE PER ZANON	COLTELLO FRESATO	361003	RICAMBIO NON ORIGINALE PER ZANON	COLTELLO DIRITTO FRESATO	361005
		60x6			60x6
		A = 145			A = 135

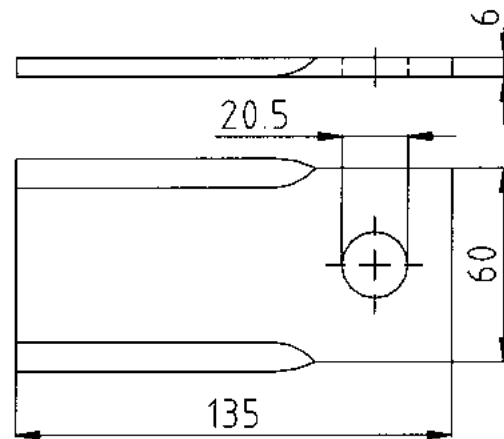
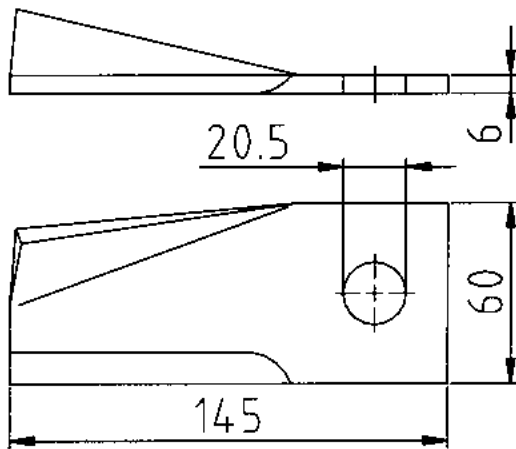





RICERCA FACILITATA RICAMBI







ZAPPETTE

Blades
Messern
Couteaux
Ножи

Interasse Center distance Achsenabstand Entraxe ø - ø	Fori Holes Löcher Trous ø mm	Codice Nr. Ref. Nr. Re. Nr. Ref. Nr.	Piatto Plate Platte Plaque mm	Curvatura Curvature Krümmung Courbure
21	8,5	212001	35x6	C
25	10,5	186008	50x6	C
25	10,5	186023	50x6	C
25	10,5	186030	50x6	C
27	10,5	123004	40x6	C
27	10,5	123005	40x6	C
27	10,5	331001	40x6	C
27	10,5	358012	40x6	C
27	10,5	358022	40x6	C
27	10,5	268020	50x6	C
27	10,5	123012	50x7	C
28	10,5	126027	45x6	C
28	10,5	126019	50x6	C
30	10,5	250006	45x6	C
30	10,5	118001	50x6	C
30	10,5	118016	50x6	C
30	10,5	144009	50x6	SQ
31	12,5	168017	60x6	C
32	10,5	158002	50x5	C
32	10,5	158003	50x5	C
32	10,5	158007	50x5	C
32	10,5	158014	50x5	C
32	10,5	301009	50x6	C
32	10,5	301010	50x6	C

ZAPPETTE

Blades
Messern
Couteaux
Ножи

Interasse Center distance Achsenabstand Entraxe ø - ø	Fori Holes Löcher Trous ø mm	Codice Nr. Ref. Nr. Re. Nr. Ref. Nr.	Piatto Plate Platte Plaque mm	Curvatura Curvature Krümmung Courbure
32	10,5	318004	60x6	C
33	8,5	210008	35x6	C
33	10,5	210029	45x5	C
35	10,5	134010	50x6	SQ
35	10,5	134010M1	50x6	C
35	10,5	259002	50x6	SQ
35	10,5	331005	50x6	C
35	10,5	338010	50x6	C
35	10,5	358002	50x6	C
35	10,5	358003	50x6	C
35	10,5	358004	50x6	SQ
35	10,5	358005	50x6	C
35	10,5	358024	50x6	C
35	14,5	236001	65x7	SQ
36	10,5	103009	70x6	SQ
37	8,5	276012	30x6	C
37	8,5	276010	35x6	C
37	10,5	136034	50x6	C
38	10,5	103011A	50x5	SQ
38	10,5	103019	50x5	SQ
39	10,5	210037	50x5	C
39	12,5	210050	70x6	C
40	8,5	134048	50x5	C
40	10,5	119003	50x6	SQ

Tutti i modelli sono di nostra produzione e non originali.
All models are of our manufacture and are not original.
Alle unsere Landwirtschaftliche erzeugnisse sind unsere produktion und sind nicht original.
Tous les modèles sont notre production et ne sont pas des produits d'origine.
Все модели нашего производства и не являются оригинальными.

N.B. Pesi e misure sopra descritti sono puramente indicativi.
N.B. The above weights and dimensions are given for reference only.
N.B. Die obengenannten Gewichte und Abmessungen sind richtungsweisend.
N.B. Les poids et les dimensions indiqués ci-dessus sont donnés à titre indicatif.
N.B. Указанные вес и размеры, являются ориентировочными.

© La riproduzione
anche parziale
del presente catalogo
è vietata.



ZAPPETTE

Blades
Messern
Couteaux
Ножи

Interasse Center distance Achsenabstand Entraxe ø - ø	Fori Holes Löcher Trous ø mm	Codice Nr. Ref. Nr. Re. Nr. Ref. Nr.	Piatto Plate Platte Plaque mm	Curvatura Curvature Krümmung Courbure
40	10,5	119004	50x6	SQ
40	10,5	301020	50x6	C
40	12,5	134020	60x6	C
40	12,5	153025	60x6	C
40	12,5	134006	70x6	C
40	12,5	134007	70x6	SQ
40	12,5	168004	70x6	SQ
40	12,5	168014	70x6	C
40	12,5	168012	70x7	C
40	14,5	252031	60x7	SQ
40	14,5	252032	60x7	C
40	14,5	252065	60x7	C
41	10,5	123003	50x6	C
41	10,5	212005	50x6	C
41	12,5	287001	40x8	C
41	12,5	304002	70x6	C
41,5	12,5	237034	70x6	C
42	8,5	276014	50x5	C
42	10,5	210036	45x5	C
42	10,5	210051	45x5	C
42	10,5	276014A	50x5	C
42	10,5	210010	60x6	C
42	10,5	210035	60x6	C
42	12,5	158006	60x6	C

ZAPPETTE

Blades
Messern
Couteaux
Ножи

Interasse Center distance Achsenabstand Entraxe ø - ø	Fori Holes Löcher Trous ø mm	Codice Nr. Ref. Nr. Re. Nr. Ref. Nr.	Piatto Plate Platte Plaque mm	Curvatura Curvature Krümmung Courbure
42	12,5	158016	60x6	C
42	12,5	191013	60x6	C
42	12,5	210027	60x6	C
42	12,5	259009	60x6	C
42	12,5	276008	60x6	C
42	12,5	301002	60x6	SQ
42	12,5	301005	60x6	C
42	12,5	301011	60x6	C
42	12,5	301012	60x6	C
42	12,5	304005	60x6	C
42	12,5	332015	60x6	C
42	12,5	332021	60x6	SQ
42	12,5	298001	70x6	SQ
42	12,5	298010	70x6	C
42	12,5	332020	70x6	C
42	12,5	350009	70x7	C
44	12,5	148010	60x6	C
44	12,5	153017	60x6	SQ
44	12,5	153018	60x6	C
44	12,5	153024	60x6	C
44	12,5	255019	60x6	SQ
44	12,5	255020	60x6	C
44	12,5	255047	60x6	SQ
44	12,5	255017	70x6	SQ



ZAPPETTE

Blades
Messern
Couteaux
Ножи

Interasse Center distance Achsenabstand Entraxe ø - ø	Fori Holes Löcher Trous ø mm	Codice Nr. Ref. Nr. Re. Nr. Ref. Nr.	Piatto Plate Platte Plaque mm	Curvatura Curvature Krümmung Courbure
44	12,5	255018	70x6	C
44	12,5	255053	70x6	C
44	12,5	255071	70x6	C
44	12,5	255034	75x6	—
44	13	255021	60x10	—
44	13	255022	60x12	—
44	14,5	255035	80x8	—
45	8,5	136012	30x4	SQ
45	10,5	358010	60x6	C
45	10,5	358018	60x6	C
45	12,5	147008	50x6	C
45	12,5	275034	75x7	C
45	14,5	134023	50x10	—
45	14,5	174001	80x6	C
45	14,5	174004	80x6	C
45	14,5	252023	80x8	—
45	14,5	252024	80x8	—
45	14,5	252025	80x8	—
45	16,5	153022	50x10	—
45	16,5	153023	50x12	—
45	16,5	304011	50x12	—
45	16,5	134047	60x10	—
46	10,5	101003	40x6	C
46	10,5	101007	50x6	C

ZAPPETTE

Blades
Messern
Couteaux
Ножи

Interasse Center distance Achsenabstand Entraxe ø - ø	Fori Holes Löcher Trous ø mm	Codice Nr. Ref. Nr. Re. Nr. Ref. Nr.	Piatto Plate Platte Plaque mm	Curvatura Curvature Krümmung Courbure
46	12,5	351002	100x10	C
46	12,5	351001	100x8	C
46	12,5	268005	60x6	SQ
46	12,5	268008	60x6	C
46	12,5	338007	60x6	C
46	12,5	338008	60x6	SQ
46	12,5	123010	60x8	C
46	12,5	191010	70x7	C
46	12,5	268004	70x7	SQ
46	12,5	268006	70x7	C
46	12,5	268007	70x7	SQ
46	12,5	338003	70x7	C
46	12,5	338004	70x7	SQ
46	14,5	109001	60x12	—
46	14,5	252007	60x7	C
46	14,5	252008	60x7	SQ
46	14,5	114003	70x7	C
46	14,5	268004A	70x7	SQ
46	14,5	268006A	70x7	C
46	14,5	338003A	70x7	C
46	14,5	338004A	70x7	SQ
46	14,5	252001	70x8	C
46	14,5	252002	70x8	SQ
46	14,5	252026	70x8	SQ

Tutti i modelli sono di nostra produzione e non originali.
All models are of our manufacture and are not original.
Alle unsere Landwirtschaftliche erzeugnisse sind unsere produktion und sind nicht original.
Tous les modèles sont notre production et ne sont pas des produits d'origine.
Все модели нашего производства и не являются оригинальными.

N.B. Pesi e misure sopra descritti sono puramente indicativi.
N.B. The above weights and dimensions are given for reference only.
N.B. Die obengenannten Gewichte und Abmessungen sind richtungsweisend.
N.B. Les poids et les dimensions indiqués ci-dessus sont donnés à titre indicatif.
N.B. Указанные вес и размеры, являются ориентировочными.

© La riproduzione
anche parziale
del presente catalogo
è vietata.



ZAPPETTE

Blades
Messern
Couteaux
Ножи

Interasse Center distance Achsenabstand Entraxe ø - ø	Fori Holes Löcher Trous ø mm	Codice Nr. Ref. Nr. Re. Nr. Ref. Nr.	Piatto Plate Platte Plaque mm	Curvatura Curvature Krümmung Courbure
46	14,5	252005	75x10	C
46	14,5	191012	80x7	C
46	14,5	134003	80x8	C
46	14,5	168007	80x8	C
46	14,5	252003	80x8	C
46	14,5	252004	80x8	SQ
46	14,5	268003	80x8	C
46	14,5	268010	80x8	C
46	14,5	338001	80x8	C
46	14,5	338011	80x8	SQ
46	14,5	338012	80x8	C
48	14,5	255036	80x6	C
48	14,5	255037	80x6	SQ
48	14,5	255067	80x7	C
48	14,5	255068	80x7	SQ
48	14,5	191020	90x8	—
50	8,5	101013	30x5	C
50	8,5	125058	30x5	C
50	12,5	153010	70x6	C
50	12,5	153011	70x6	SQ
50	14,5	302014	70x10	C
50	14,5	302028	70x10	—
50	14,5	153027	70x7	SQ
50	14,5	153028	70x7	C

ZAPPETTE

Blades
Messern
Couteaux
Ножи

Interasse Center distance Achsenabstand Entraxe ø - ø	Fori Holes Löcher Trous ø mm	Codice Nr. Ref. Nr. Re. Nr. Ref. Nr.	Piatto Plate Platte Plaque mm	Curvatura Curvature Krümmung Courbure
50	14,5	262008	80x7	C
50	14,5	262025	80x7	SQ
50	14,5	262027	80x7	C
50	14,5	262002	80x8	SQ
50	14,5	262003	80x8	SQ
50	14,5	262009	80x8	C
50	14,5	262011	80x8	C
50	14,5	262026	80x8	C
50	16,5	225019	50x12	—
50	16,5	237006	50x12	—
50	16,5	225030	60x12	—
51	16,5	225016	80x9	SQ
51	16,5	225017	80x9	C
51	16,5	225024	90x8	SQ
51	16,5	225025	90x8	SQ
53	12,5	210040	60x6	C
54	12,5	210026	70x6	C
54	12,5	210033	70x6	C
54	12,5	302005	70x7	C
55	8,5	331017	25x5	C
55	8,5	123001	25x6	C
55	8,5	123007	25x6	C
55	8,5	302035	25x6	C
55	8,5	331011	25x6	C



ZAPPETTE

Blades
Messern
Couteaux
Ножи

Interasse Center distance Achsenabstand Entraxe ø - ø	Fori Holes Löcher Trous ø mm	Codice Nr. Ref. Nr. Re. Nr. Ref. Nr.	Piatto Plate Platte Plaque mm	Curvatura Curvature Krümmung Courbure
55	8,5	250001	30x4	SQ
55	8,5	123014	30x6	C
55	8,5	123015	30x6	C
55	8,5	126023	30x6	C
55	8,5	126024	30x6	C
55	8,5	126026	30x6	C
55	8,5	147010	30x6	C
55	8,5	212015	30x6	C
55	8,5	212041	30x6	C
55	12,5	275022	75x7	C
55	12,5	275031	80x7	SQ
55	12,5	211002	80x8	C
55	14,5	275019	80x7	C
55	14,5	332022	80x7	C
55	14,5	332023	80x7	SQ
55	14,5	332024	80x7	C
55	14,5	332025	80x7	SQ
55	14,5	275028	80x8	SQ
56	10,5	255027	60x5	C
56	14,5	191021	100x8	—
56	14,5	122005	60x8	SQ
56	14,5	158043	70x8	C
56	14,5	255014	80x6	SQ
56	14,5	255015	80x6	C

ZAPPETTE

Blades
Messern
Couteaux
Ножи

Interasse Center distance Achsenabstand Entraxe ø - ø	Fori Holes Löcher Trous ø mm	Codice Nr. Ref. Nr. Re. Nr. Ref. Nr.	Piatto Plate Platte Plaque mm	Curvatura Curvature Krümmung Courbure
56	14,5	304012	80x6	C
56	14,5	304016	80x6	SQ
56	14,5	255065	80x7	SQ
56	14,5	255066	80x7	C
56	14,5	304014	80x7	C
56	14,5	304015	80x7	SQ
56	14,5	255012	80x8	SQ
56	14,5	255013	80x8	C
56	14,5	350014	80x8	C
56	14,5	350015	80x8	SQ
57	11,5	225010	75x6	SQ
57	11,5	237001	75x6	SQ
57	11,5	225001	80x6	SQ
57	11,5	225004	80x6	C
57	11,5	225008	80x7	SQ
57	12,5	134008	80x7	C
57	12,5	134011	80x7	SQ
57	12,5	134013	80x7	C
57	13,5	225002	80x7	SQ
57	13,5	225005	80x7	C
57	13,5	225009	80x7	SQ
57	13,5	225013	80x7	C
57	13,5	225040	90x6	SQ
57	13,5	225026	90x8	SQ

Tutti i modelli sono di nostra produzione e non originali.
All models are of our manufacture and are not original.
Alle unsere Landwirtschaftliche erzeugnisse sind unsere produktion und sind nicht original.
Tous les modèles sont notre production et ne sont pas des produits d'origine.
Все модели нашего производства и не являются оригинальными.

N.B. Pesi e misure sopra descritti sono puramente indicativi.
N.B. The above weights and dimensions are given for reference only.
N.B. Die obengenannten Gewichte und Abmessungen sind richtungsweisend.
N.B. Les poids et les dimensions indiqués ci-dessus sont donnés à titre indicatif.
N.B. Указанные вес и размеры, являются ориентировочными.

© La riproduzione
anche parziale
del presente catalogo
è vietata.



ZAPPETTE

Blades
Messern
Couteaux
Ножи

Interasse Center distance Achsenabstand Entraxe ø - ø	Fori Holes Löcher Trous ø mm	Codice Nr. Ref. Nr. Re. Nr. Ref. Nr.	Piatto Plate Platte Plaque mm	Curvatura Curvature Krümmung Courbure
57	14,5	153013	80x6	C
57	14,5	153014	80x6	SQ
57	14,5	153003	80x7	SQ
57	14,5	153004	80x7	C
57	14,5	181009	80x7	C
57	14,5	236008	80x7	SQ
57	14,5	237008	80x7	SQ
57	14,5	298002	80x7	SQ
57	14,5	113005	80x8	C
57	14,5	153015	80x8	C
57	14,5	153016	80x8	SQ
57	14,5	153021	80x8	SQ
57	14,5	298003	80x8	SQ
57	14,5	302008	80x8	SQ
57	14,5	302009	80x8	C
57	16,5	237023	90x8	SQ
57-34	12,5	148007	80x7	SQ
57-34	12,5	148008	80x7	C
58	8,5	276017	25x5	C
58	10,5	126001	30x8	C
59	14,5	350013	80x8	SQ
60	8,5	136013	30x6	SQ
60	8,5	136018	35x6	C
60	8,5	136037	35x6	SQ

ZAPPETTE

Blades
Messern
Couteaux
Ножи

Interasse Center distance Achsenabstand Entraxe ø - ø	Fori Holes Löcher Trous ø mm	Codice Nr. Ref. Nr. Re. Nr. Ref. Nr.	Piatto Plate Platte Plaque mm	Curvatura Curvature Krümmung Courbure
64	14,5	153037	80x8	SQ
64	14,5	153038	80x8	SQ
64/72	10,5x18,5	169011	45x6	C
65	8,5	126025	30x4	C
65	8,5	176013	30x4	C
65	8,5	176003	30x5	C
65	10,5	186027	25x5	C
65	10,5	321005	25x5	C
65	10,5	186010	30x6	C
65	10,5	321007	35x5	C
65	10,5	186025	35x6	C
65	10,5	193009	45x6	C
65	12,5	255016	60x6	C
65	14,5	153008	70x8	C
65	14,5	153009	70x8	C
65/73		169010	40x6	C
66	10,5	123002	30x6	C
66	10,5	212003	30x6	C
66	10,5	212016	35x6	C
66	10,5	212030	40x6	C
66	10,5	321003	45x6	C
66	13	302018	100x14	—
66	13	113002	70x18	—
66	13	302016	70x18	—



ZAPPETTE

Blades
Messern
Couteaux
Ножи

Interasse Center distance Achsenabstand Entraxe ø - ø	Fori Holes Löcher Trous ø mm	Codice Nr. Ref. Nr. Re. Nr. Ref. Nr.	Piatto Plate Platte Plaque mm	Curvatura Curvature Krümmung Courbure
66	13	302017	70x18	—
66/73	8,5x15,5	169014	35x5	C
68	8,5	301014	25x5	C
68	8,5	125030	30x4	SQ
68	8,5	125050	30x4	C
68	8,5	212043	30x4	C
68	8,5	121015	30x5	C
68	8,5	125001	30x5	C
68	8,5	125031	30x5	C
68	8,5	125059	35x4	C
68	8,5	121021	35x5	C
68	8,5	125019	35x5	C
68	8,5	125027	40x5	C
68	8,5	125028	40x5	SQ
68	10,5	301019	30x6	C
68	10,5	125047	35x5	C
68	10,5	121032	40x5	C
68	10,5	125039	40x5	C
68	10,5	125040	40x6	C
68	10,5	125045	40x6	SQ
68	10,5	125025	45x6	C
68	10,5	125026	45x6	SQ
68	16,5	255025	90x10	C
68	16,5	255026	90x10	SQ

ZAPPETTE

Blades
Messern
Couteaux
Ножи

Interasse Center distance Achsenabstand Entraxe ø - ø	Fori Holes Löcher Trous ø mm	Codice Nr. Ref. Nr. Re. Nr. Ref. Nr.	Piatto Plate Platte Plaque mm	Curvatura Curvature Krümmung Courbure
68-74	8,5	Uncino 01	30x6	—
68-74	10,5	Uncino 02	35x6	—
68-80	8,5	Uncino 03	30x6	—
68-80	10,5	Uncino 01/A	30x6	—
68-80	10,5	136038	40x6	SQ
68-80	10,5	300034	40x6	C
68-80	10,5	300036	45x6	C
68-80	10,5	300035	50x6	C
70	8,5	103001	30x4	SQ
70	8,5	103002	30x4	SQ
70	8,5	103003	30x4	SQ
70	8,5	103016	30x4	SQ
70	8,5	134001	30x6	SQ
70	8,5	224007	30x6	C
70	8,5	331009	30x6	C
70	8,5	224004	35x6	C
70	8,5	224006	35x6	C
70	8,5	224017	40x4	C
70	8,5	331026	40x4	C
70	8,5	193014	40x5	C
70	10,5	331008	35x6	C
70	10,5	358023	35x6	C
70	10,5	125054	40x5	C
70	10,5	331025	40x5	C

Tutti i modelli sono di nostra produzione e non originali.
All models are of our manufacture and are not original.
Alle unsere Landwirtschaftliche erzeugnisse sind unsere produktion und sind nicht original.
Tous les modèles sont notre production et ne sont pas des produits d'origine.
Все модели нашего производства и не являются оригинальными.

N.B. Pesi e misure sopra descritti sono puramente indicativi.
N.B. The above weights and dimensions are given for reference only.
N.B. Die obengenannten Gewichte und Abmessungen sind richtungsweisend.
N.B. Les poids et les dimensions indiqués ci-dessus sont donnés à titre indicatif.
N.B. Указанные вес и размеры, являются ориентировочными.

© La riproduzione
anche parziale
del presente catalogo
è vietata.



ZAPPETTE

Blades
Messern
Couteaux
Ножи

Interasse Center distance Achsenabstand Entraxe Ø - Ø	Fori Holes Löcher Trous Ø mm	Codice Nr. Ref. Nr. Re. Nr. Ref. Nr.	Piatto Plate Platte Plaque mm	Curvatura Curvature Krümmung Courbure
70	10,5	136005A	40x6	C
70	10,5	136006A	40x6	C
70	10,5	136007A	40x6	SQ
70	10,5	136008A	40x6	SQ
70	10,5	210043	40x6	C
70	10,5	136023	45x6	C
70	10,5	136024	45x6	C
70	10,5	136025	45x6	SQ
70	10,5	136026	45x6	SQ
70	10,5	331006	45x6	C
70	10,5	331010	45x6	C
70	10,5	358021	45x6	C
70	10,5	136027	50x6	C
70	10,5	136028	50x6	C
72	8,5	149014	30x6	C
72	8,5	149015	35x6	C
72	8,5	149018	35x6	SQ
72	10,5	149022	45x6	C
73	8,5	300025	35x6	C
73	10,5	176004	40x6	C
73	10,5	300020	40x6	C
73	10,5	300020M2	45x6	C
73	10,5	300010	50x6	C
73	10,5	300020M1	50x6	C

ZAPPETTE

Blades
Messern
Couteaux
Ножи

Interasse Center distance Achsenabstand Entraxe Ø - Ø	Fori Holes Löcher Trous Ø mm	Codice Nr. Ref. Nr. Re. Nr. Ref. Nr.	Piatto Plate Platte Plaque mm	Curvatura Curvature Krümmung Courbure
75	16,5	181037	105x8	C
75	16,5	225006	105x8	SQ
75	16,5	225046	105x8	C
76	10,5	121007	40x6	C
76	10,5	121033	40x6	C
76	10,5	193010	45x6	C
76	16,5	140012	100x10	SQ
76	16,5	237004	105x8	SQ
80	10,5	224014	35x5	C
80	10,5	224015	35x5	C
80	10,5	301003	35x8	C
80	10,5	189014A	40x5	C
80	10,5	210031	45x5	C
80	10,5	210032	45x5	SQ
80	10,5	189009	45x6	C
80	10,5	125023	50x6	C
80	10,5	189003	50x6	C
81	8,5	126004	30x6	C
81	8,5	126016	30x6	C
85	10,5	250004	35x5	SQ
85	10,5	250005	40x5	C
85	10,5	250007	40x6	C
85	10,5	250008	40x6	SQ
86	12,5	237028	60x6	C



COLTELLI E LAME PER TRINCIA E DECESPUGLIATORI

Knives and blades for choppers and flail-mowers
Hammerschlegel und Schlegelmesser
Couteaux et lames pour hacheuses et debroussailleuses
Ножи и лезвия для мульчирователей и косилок

Piatto Plate Platte Plaque mm	Fori Holes Löcher Trous Ø mm	Codice Nr. Ref. Nr. Re. Nr. Ref. Nr.
25x6	28,5	131009
30x10	12,5x32,5	353001
30x3	11	252020
30x3	12,5	123022
30x3	11x20	114011
30x4	10,5	Orec/01
30x4	27x13	306001
30x5	18	252053
30x5	23x10	201001
30x8	12,5	278002
30x8	18	252034
30x8	25,5	138017
30x8	25,5	238003
30x8	25,5	348001
32x6,5	13,5	151016
34x8	26	181031
34x8	26	279016
34x8	26	279023
34x8	26	304007
35x10	12,5x32,5	353002
35x10	13x33	359001
35x10	13x33	372013
35x5	14,5	112009
35x5	14,5	268032

COLTELLI E LAME PER TRINCIA E DECESPUGLIATORI

Knives and blades for choppers and flail-mowers
Hammerschlegel und Schlegelmesser
Couteaux et lames pour hacheuses et debroussailleuses
Ножи и лезвия для мульчирователей и косилок

Piatto Plate Platte Plaque mm	Fori Holes Löcher Trous Ø mm	Codice Nr. Ref. Nr. Re. Nr. Ref. Nr.
35x8	14,5	346004
35x8	14x27	322008
35x8	14x27	336016
35x8	30x15	237029
35x8	34x14	trincia/02
40x10	14,5	252047
40x10	16,5	105010
40x10	16,5	105011
40x10	16,5	252039
40x10	16,5	252079
40x10	16,5	298006
40x10	16,5	298007
40x10	16,5	347012
40x10	17	196006
40x10	20,5	137001
40x10	14x39	173001
40x12	16,5	138003
40x12	19,5	138024
40x12	16x36	181024
40x15	16,5	138004
40x15	19,5	138025
40x5	10	145003
40x5	12,5	298015
40x5	14,5	252015



COLTELLI E LAME PER TRINCIA E DECESPUGLIATORI

Knives and blades for choppers and flail-mowers
Hammerschlegel und Schlegelmesser
Couteaux et lames pour hacheuses et debroussailleuses
Ножи и лезвия для мульчирователей и косилок

Piatto Plate Platte Plaque mm	Fori Holes Löcher Trous ø mm	Codice Nr. Ref. Nr. Re. Nr. Ref. Nr.
40x5	14,5	322001
40x5	14,5	336003
40x5	13x26	336001
40x5	13x26	336002
40x5	13x26	336002
40x5	13x27	269004
40x5	14x26	252016
40x5	14x26	322004
40x5	14x26	348006
40x5	27x13	145004
40x5	33x14	trincia/04
40x6	12,5	187036
40x6	12,5	187037
40x6	16,5	307003
40x6	16x32	132001
40x6	30x14	333016
40x6	35x17	187028
40x6	35x17	187039
40x6,5	31x16	trincia/05
40x8	12,5	137006
40x8	16,5	108001
40x8	16,5	187023
40x8	16,5	279002
40x8	16,5	279007

COLTELLI E LAME PER TRINCIA E DECESPUGLIATORI

Knives and blades for choppers and flail-mowers
Hammerschlegel und Schlegelmesser
Couteaux et lames pour hacheuses et debroussailleuses
Ножи и лезвия для мульчирователей и косилок

Piatto Plate Platte Plaque mm	Fori Holes Löcher Trous ø mm	Codice Nr. Ref. Nr. Re. Nr. Ref. Nr.
40x8	16,5	279012
40x8	16,5	279032
40x8	20,5	112002
40x8	20,5	268033
40x8	20,5	295005
40x8	20,5	361001
40x8	28	360006
40x8	14x26	336007
40x8	14x27	150011
40x8	14x29	361002
40x8	14x30	187014
40x8	14x30	259020
40x8	17x35	187016
40x8	30x14	138021
40x8	30x14	187032
40x8	30x14	295008
40x8	35x16	295003
45x10	16,5	259043
45x3	13x27	269002
45x4	14x26	269005
45x5	20,5	137002
45x5	19x14	272001
45x6	14x32	269003
45x6	14x32	269007

Tutti i modelli sono di nostra produzione e non originali.
All models are of our manufacture and are not original.
Alle unsere Landwirtschaftliche erzeugnisse sind unsere produktion und sind nicht original.
Tous les modèles sont notre production et ne sont pas des produits d'origine.
Все модели нашего производства и не являются оригинальными.

N.B. Pesi e misure sopra descritti sono puramente indicativi.
N.B. The above weights and dimensions are given for reference only.
N.B. Die obengenannten Gewichte und Abmessungen sind richtungsweisend.
N.B. Les poids et les dimensions indiqués ci-dessus sont donnés à titre indicatif.
N.B. Указанные вес и размеры, являются ориентировочными.

© La riproduzione
anche parziale
del presente catalogo
è vietata.



COLTELLI E LAME PER TRINCIA E DECESPUGLIATORI

Knives and blades for choppers and flail-mowers
Hammerschlegel und Schlegelmesser
Couteaux et lames pour hacheuses et debroussailleuses
Ножи и лезвия для мульчирователей и косилок

Piatto Plate Platte Plaque mm	Fori Holes Löcher Trous Ø mm	Codice Nr. Ref. Nr. Re. Nr. Ref. Nr.
45x8	16,5	279020
45x8	16,5	348002
45x8	16,5	348003
45x8	16,5	348004
45x8	16x38	trincia/07
45x8	30x14	293016
50x10	16,5	153053
50x10	16,5	153054
50x10	16,5	252021
50x10	16,5	252022
50x10	16,5	298016
50x10	18,5	238004
50x10	20,5	137015
50x10	25,5	285014
50x10	25,5	285019
50x10	25,5	295002
50x10	27,5	137016
50x10	14x27	150014
50x10	19x36	229001
50x12	20,5	150026
50x6	27	106002
50x8	16,5	227001
50x8	20,5	150027
50x8	20,5	293003

COLTELLI E LAME PER TRINCIA E DECESPUGLIATORI

Knives and blades for choppers and flail-mowers
Hammerschlegel und Schlegelmesser
Couteaux et lames pour hacheuses et debroussailleuses
Ножи и лезвия для мульчирователей и косилок

Piatto Plate Platte Plaque mm	Fori Holes Löcher Trous Ø mm	Codice Nr. Ref. Nr. Re. Nr. Ref. Nr.
50x8	25,5	298021
50x8	14x35	372014
60x10	20,5	255042
60x10	20,5	266062
60x10	20,5	372002
60x10	20,5	372008
60x10	22,5	346014
60x10	25,5	112004
60x10	25,5	112005
60x10	25,5	138005
60x10	25,5	181002
60x10	25,5	181014
60x10	25,5	181020
60x10	25,5	259005
60x10	25,5	259008
60x10	25,5	279003
60x10	25,5	279004
60x10	25,5	279005
60x10	25,5	285006
60x10	25,5	285013
60x10	25,5	304006
60x10	28,5	278004
60x6	25,5	307002
60x7	25	330001



COLTELLI E LAME PER TRINCIA E DECESPUGLIATORI

Knives and blades for choppers and flail-mowers
Hammerschlegel und Schlegelmesser
Couteaux et lames pour hacheuses et débroussailleuses
Ножи и лезвия для мульчирователей и косилок

Piatto Plate Platte Plaque mm	Fori Holes Löcher Trous Ø mm	Codice Nr. Ref. Nr. Re. Nr. Ref. Nr.
60x7	25,5	238007
60x7	25,5	347004
60x7	28,5	143001
60x8	16,5	295001
60x8	20,5	293020
60x8	25,5	112003
60x8	25,5	138001
60x8	25,5	138002
60x8	25,5	167001
60x8	25,5	167002
60x8	25,5	187001
60x8	25,5	187004
60x8	25,5	187005
60x8	25,5	187006
60x8	25,5	187026
60x8	25,5	187027
60x8	25,5	238002
60x8	25,5	279001
60x8	25,5	295004
60x8	25,5	298011
60x8	25,5	304024
60x8	25,5	333003
60x8	25,5	348005
60x8	25,5	348008

COLTELLI E LAME PER TRINCIA E DECESPUGLIATORI

Knives and blades for choppers and flail-mowers
Hammerschlegel und Schlegelmesser
Couteaux et lames pour hacheuses et débroussailleuses
Ножи и лезвия для мульчирователей и косилок

Piatto Plate Platte Plaque mm	Fori Holes Löcher Trous Ø mm	Codice Nr. Ref. Nr. Re. Nr. Ref. Nr.
60x8	25,5	348009
60x8	25,5	348010
60x8	25,5	360009
60x8	25,5	360010
60x8	26,5	107001
60x8	28,5	131001
60x8	28,5	131002
60x8	28,5	131003
60x8	28,5	131015
60x8	28,5	131016
60x8	30	265003
65x6	14,5	129004
65x6	28,5	363001
65x6,5	12,5	233002
65x6,5	29,5	346003
70x10	16,5	252087
70x10	25,5	279022
70x3	10,5	357004
70x3	10,5	357005
70x3	12,5	123019
70x3	12,5	357010
70x3	14x19	348011
70x3	14x19	357001
70x3	14x19	357002



COLTELLI E LAME PER TRINCIA E DECESPUGLIATORI

Knives and blades for choppers and flail-mowers
Hammerschlegel und Schlegelmesser
Couteaux et lames pour hacheuses et debroussailleuses
Ножи и лезвия для мульчирователей и косилок

Piatto Plate Plaque mm	Fori Holes Löcher Trous Ø mm	Codice Nr. Ref. Nr. Re. Nr. Ref. Nr.
70x3	14x25	298026
70x3	14x25	333026
70x3	14x25	357003
75x7	12,5	278001
75x7	14	346002
80x8	12,5	285010
80x8	12,5	285011
90x6	12,5	233001
100x6	17	279024
100x8	18	252073
100x8	26	298019
100x8	28	285005
100x8	28,5	138007